

MAIN CATALOGUE

# 2019

LAVOR EQUIPMENT



MotoGP™ WORLD CHAMPIONSHIP 2019/2020/2021

**35**

Cal Crutchlow



MAJOR SPONSOR

**LCR**

TEAM

**Honda**

# LAVOR

*SIMPLY STRONGER*

EN



## **www.lavor.it**

a website, full of useful information, offering expanded and constantly updated contents: each product sheet contains in addition to texts, technical specifications, standard and optional accessories and also the possibility to download technical data sheet and instruction manual as well.



**www.lavor.it**

## **www.lavor.it**

a website easy to explore and showing all the information about Lavor products: it offers easy exploration and complete technical information. A website of modern concept helping our customer finding the necessary updated information about our products, easily and in real time. It offers complete product videos about machine running, machine use and plus of the main products of professional range: an additional very useful sales tool.

## **www.lavor.it**

connecting to the Lavor world is just a click away: complete information, products, videos and news available quickly and simply.

Watch the video on youtube:  
[www.youtube.com/lavortv](http://www.youtube.com/lavortv)  
[www.youtube.com/lavorpro](http://www.youtube.com/lavorpro)





**Yongkang Lavorwash Equipment Co. Ltd.** set up in 2004 as a manufacturing and commercial branch of Lavorwash Spa, Italian company set up in 1975, one of the world's most important manufacturers of high-tech cleaning systems for small and large surfaces for more than 40 years. Nowadays the company has an increasing consolidated turnover and more than 350 employees situated in several branches in Italy, China, Brazil, France, Spain, Poland and UK.

**The company recently celebrated the opening of its new headquarters which includes a warehouse, but more importantly a larger factory, with more space and improved organisation for production, for a total of 30,000 sqm.**



**Yongkang**

Lavor equipment Co. Ltd

## **Tecnology and design**

Relying on more than forty years of experience and on the technical know-how of Lavorwash Group, new models and new products are followed step by step by resident Italian engineers.

**The opening of the new facility has led to an increase in the varieties of models in the range, providing greater flexibility in production and the possibility of developing new products.**



NEW FACTORY VIDEO





### **Italian management**

*Italian managers, engineers and employees run the company. Yongkang Lavorwash Equipment Co. Ltd stretches over more than 30,000 square meters, with a growing number of employees continuously increasing.*

### **Quality and service**

*The LAVOR brand assures the quality of all products certified by leading certificate Corporations such as GS, UL, TUV-SUD, and INMETRO. Product quality is also certified by in-house testing on 100% of products, and with the possibility of FFU certified work for individual clients.*

***The larger area of the new facility has allowed the company to streamline quality control thanks to the set-up of new testing spaces and rooms with new equipment.***





### Fast 120

- Three pistons, aluminium pump head with built-in by-pass valve
- Automatic Stop System
- Accessory storage facility
- Ergonomic handle
- Standard set of accessories



#### COLD WATER HIGH-PRESSURE CLEANERS

code	8.109.0007C
barcode	8013298207114
max pressure (bar)	120
max delivery rate (l/h)	330
abs. power (W)	1700
weight (Kg)	5,6
packing dim. (cm)	25 x 30 h 40
pcs for pallet	60

Load Q.ty: 20'=980 40'=2010 40' HC=2300

Available also 110/120V - 60Hz version: 1300 psi - 1.35 GPM (USA) - 1300W

#### STANDARD EQUIPMENT



#### STANDARD EQUIPMENT



#### COLD WATER HIGH-PRESSURE CLEANERS

code	8.109.0008C
barcode	8013298220712
max pressure (bar)	130
max delivery rate (l/h)	390
abs. power (W)	1800
weight (Kg)	6,9
packing dim. (cm)	32,5 x 27,5 h 44
pcs for pallet	48

Load Q.ty: 20'=731 40'=1501 40' HC=1802

Available also 110/120V - 60Hz version: 1400 psi - 1.55 GPM (USA) - 1350W

### Fast Plus 130

- Three pistons, aluminium pump head with built-in by-pass valve
- Automatic Stop System
- Accessory storage facility
- Ergonomic handle
- Standard set of accessories
- Turbo lance



### Fast Extra 145

- Three pistons, aluminium pump head with built-in by-pass valve
- Automatic Stop System
- Hose-reel
- Accessory storage facility
- Ergonomic handle
- Turbo lance



#### COLD WATER HIGH-PRESSURE CLEANERS

code	8.109.0009C
barcode	8013298207138
max pressure (bar)	145
max delivery rate (l/h)	420
abs. power (W)	1900
weight (Kg)	8
packing dim. (cm)	32,5 x 27,5 h 44
pcs for pallet	48

Load Q.ty: 20'=731 40'=1501 40' HC=1802

Available also 110/120V - 60Hz version: 1400 psi - 1.55 GPM (USA) - 1350W

#### STANDARD EQUIPMENT

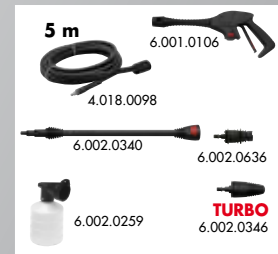



## One 120

- Three pistons, aluminium pump head with built-in by-pass valve
- Automatic Stop System
- Accessory storage facility
- Ergonomic handle
- Standard set of accessories



### COLD WATER HIGH-PRESSURE CLEANERS

code	8.103.0001C
barcode	8013298204472
max pressure (bar)	120
max delivery rate (l/h)	330
abs. power (W)	1700
weight (Kg)	5,6
packing dim. (cm)	25 x 30 h 40
pcs for pallet	60

Load Q.ty: 20'=980 40'=2010 40' HC=2300

Available also 110/120V - 60Hz version: 1300 psi - 1.35 GPM (USA) - 1300W

### STANDARD EQUIPMENT



### STANDARD EQUIPMENT



### COLD WATER HIGH-PRESSURE CLEANERS

code	8.103.0005C
barcode	8013298204892
max pressure (bar)	130
max delivery rate (l/h)	420
abs. power (W)	1800
weight (Kg)	6,9
packing dim. (cm)	26,5 x 29,5 h 56
pcs for pallet	36

Load Q.ty: 20'=648 40'=1360 40' HC=1536

Available also 110/120V - 60Hz version: 1400 psi - 1.55 GPM (USA) - 1350W

## One Plus 130

- Three pistons, aluminium pump head with built-in by-pass valve
- Automatic Stop System
- Accessory storage facility
- Ergonomic handle
- Standard set of accessories
- Turbo lance
- Rotary brush
- Fixed brush



## One Extra 135

- Three pistons, aluminium pump head with built-in by-pass valve
- Automatic Stop System
- Hose-reel
- Accessory storage facility
- Ergonomic handle
- Turbo lance
- Rotary brush
- Fixed brush
- Patio cleaner



### COLD WATER HIGH-PRESSURE CLEANERS

code	8.103.0008C
barcode	8013298204939
max pressure (bar)	135
max delivery rate (l/h)	420
abs. power (W)	1900
weight (Kg)	8
packing dim. (cm)	26,5 x 29,5 h 60
pcs for pallet	36

Load Q.ty: 20'=576 40'=1216 40' HC=1376

Available also 110/120V - 60Hz version: 1400 psi - 1.55 GPM (USA) - 1350W

### STANDARD EQUIPMENT



Available also One Extra 135 without patio cleaner, and fixed brush - Code 8.103.0007C



### Smart 120



- Three pistons, aluminium pump head with built-in by-pass valve
- Automatic Stop System
- Accessory storage facility
- Ergonomic handle
- Standard set of accessories



#### COLD WATER HIGH-PRESSURE CLEANERS

code	8.106.0004C
barcode	8013298205424
max pressure (bar)	120
max delivery rate (l/h)	330
abs. power (W)	1700
weight (Kg)	5,6
packing dim. (cm)	25 x 30 h 40
pcs for pallet	60

Load Q.ty: 20'=980 40'=2010 40' HC=2300

Available also 110/120V - 60Hz version: 1300 psi - 1.35 GPM (USA) - 1300W

#### STANDARD EQUIPMENT



#### STANDARD EQUIPMENT



#### COLD WATER HIGH-PRESSURE CLEANERS

code	8.106.0005C
barcode	8013298205448
max pressure (bar)	130
max delivery rate (l/h)	420
abs. power (W)	1800
weight (Kg)	6,9
packing dim. (cm)	26,5 x 29,5 h 56
pcs for pallet	36

Load Q.ty: 20'=648 40'=1360 40' HC=1536

Available also 110/120V - 60Hz version: 1400 psi - 1.55 GPM (USA) - 1350W

### Smart Plus 130

- Three pistons, aluminium pump head with built-in by-pass valve
- Automatic Stop System
- Accessory storage facility
- Ergonomic handle
- Standard set of accessories
- Turbo lance
- Rotary brush
- Fixed brush



### Smart Extra 135



- Three pistons, aluminium pump head with built-in by-pass valve
- Automatic Stop System
- Hose-reel
- Accessory storage facility
- Ergonomic handle
- Turbo lance
- Rotary brush
- Fixed brush
- Patio cleaner



#### COLD WATER HIGH-PRESSURE CLEANERS

code	On request
barcode	-
max pressure (bar)	135
max delivery rate (l/h)	420
abs. power (W)	1900
weight (Kg)	8
packing dim. (cm)	26,5 x 29,5 h 60
pcs for pallet	36

Load Q.ty: 20'=576 40'=1216 40' HC=1376

Available also 110/120V - 60Hz version: 1400 psi - 1.55 GPM (USA) - 1350W

#### STANDARD EQUIPMENT







**NEW**

## NJ 120

- Three pistons, aluminium pump head with built-in by-pass valve
- Automatic Stop System
- Hose-holder
- Accessory storage facility
- Ergonomic handle
- Standard set of accessories



### COLD WATER HIGH-PRESSURE CLEANERS

code	8.092.0081C
barcode	8013298211395
max pressure (bar)	120
max delivery rate (l/h)	360
abs. power (W)	1700
weight (Kg)	6,8
packing dim. (cm)	39 x 26 h 52
pcs for pallet	36

Load Q.ty: 20'=532 40'=1140 40' HC=1270

Available also 110/120V - 60Hz version: 1300 psi - 1.35 GPM (USA) - 1300W

### STANDARD EQUIPMENT



### STANDARD EQUIPMENT



### COLD WATER HIGH-PRESSURE CLEANERS

code	8.092.0082C
barcode	8013298211401
max pressure (bar)	130
max delivery rate (l/h)	420
abs. power (W)	1800
weight (Kg)	8
dimensions (cm)	39 x 26 h 52
pcs for pallet	36

Load Q.ty: 20'=532 40'=1140 40' HC=1270

Available also 110/120V - 60Hz version: 1400 psi - 1.55 GPM (USA) - 1350W

## NJ Plus 130

- Three pistons, aluminium pump head with built-in by-pass valve
- Automatic Stop System
- Hose-holder
- Accessory storage facility
- Ergonomic handle
- Turbo lance
- Fixed brush



**NEW**

Available also NJ Plus 130 with patio cleaner - Code 8.092.0083C



**NEW**

## NJ Extra 145

- Three pistons, aluminium pump head with built-in by-pass valve
- Automatic Stop System
- Hose-reel
- Accessory storage facility
- Ergonomic handle
- Turbo lance
- Rotary brush



### COLD WATER HIGH-PRESSURE CLEANERS

code	8.092.0084C
barcode	8013298211425
max pressure (bar)	145
max delivery rate (l/h)	420
abs. power (W)	1900
weight (Kg)	8,5
dimensions (cm)	39,5 x 26 h 52
pcs for pallet	36

Load Q.ty: 20'=532 40'=1140 40' HC=1270

Available also 110/120V - 60Hz version: 1500 psi max - 1.55 GPM (USA) max - 1400W

### STANDARD EQUIPMENT





### Ninja 120

- Three pistons, aluminium pump head with built-in by-pass valve
- Automatic Stop System
- Hose-holder
- Accessory storage facility
- Ergonomic handle
- Standard set of accessories



#### COLD WATER HIGH-PRESSURE CLEANERS

code	8.092.0001C
barcode	8013298200870
max pressure (bar)	120
max delivery rate (l/h)	360
abs. power (W)	1700
weight (Kg)	6,8
packing dim. (cm)	39 x 26 h 52
pcs for pallet	36

Load Q.ty: 20'=532 40'=1140 40' HC=1270

Available also 110/120V - 60Hz version: 1300 psi - 1.35 GPM (USA) - 1300W

#### STANDARD EQUIPMENT



#### STANDARD EQUIPMENT



#### COLD WATER HIGH-PRESSURE CLEANERS

code	8.092.0004C
barcode	8013298201228
max pressure (bar)	130
max delivery rate (l/h)	420
abs. power (W)	1800
weight (Kg)	8
dimensions (cm)	39 x 26 h 52
pcs for pallet	36

Load Q.ty: 20'=532 40'=1140 40' HC=1270

Available also 110/120V - 60Hz version: 1400 psi - 1.55 GPM (USA) - 1350W

### Ninja Plus 130

- Three pistons, aluminium pump head with built-in by-pass valve
- Automatic Stop System
- Hose-holder
- Accessory storage facility
- Ergonomic handle
- Turbo lance
- Fixed brush



Available also Ninja Plus 130 with patio cleaner - Code 8.092.0028C



### Ninja Extra 145

- Three pistons, aluminium pump head with built-in by-pass valve
- Automatic Stop System
- Hose-reel
- Accessory storage facility
- Ergonomic handle
- Turbo lance
- Rotary brush



#### COLD WATER HIGH-PRESSURE CLEANERS

code	8.092.0059C
barcode	8013298207183
max pressure (bar)	145
max delivery rate (l/h)	420
abs. power (W)	1900
weight (Kg)	8,5
dimensions (cm)	39,5 x 26 h 52
pcs for pallet	36

Load Q.ty: 20'=532 40'=1140 40' HC=1270

Available also 110/120V - 60Hz version: 1500 psi max - 1.55 GPM (USA) max - 1400W

#### STANDARD EQUIPMENT



Available also Ninja Extra 145 with patio cleaner - Code 8.092.0069C



## Wave 110

- Three pistons, aluminium pump head with built-in by-pass valve
- Built-in detergent tank for direct suction
- Automatic Stop System
- Ergonomic handle
- Accessory storage facility
- Standard set of accessories
- Turbo lance
- Inlet filter



### COLD WATER HIGH-PRESSURE CLEANERS

code	8.088.0005C
barcode	8013298200122
max pressure (bar)	110
max delivery rate (l/h)	330
abs. power (W)	1700
weight (Kg)	7,2
dimensions (cm)	29,5 x 26,5 h 54
pcs for pallet	36

Load Q.ty: 20'=648 40'=1360 40' HC=1536

Available also 110/120V - 60Hz version: 1300 psi max - 1.35 GPM (USA) max - 1300W

### STANDARD EQUIPMENT



### STANDARD EQUIPMENT



### COLD WATER HIGH-PRESSURE CLEANERS

code	8.088.0006C
barcode	8013298200139
max pressure (bar)	125
max delivery rate (l/h)	400
abs. power (W)	1800
weight (Kg)	7,5
dimensions (cm)	29,5 x 26,5 h 56
pcs for pallet	36

Load Q.ty: 20'=648 40'=1360 40' HC=1536

Available also 110/120V - 60Hz version: 1400 psi max - 1.55 GPM (USA) max - 1350W

## Wave UP 125

- Three pistons, aluminium pump head with built-in by-pass valve.
- Built-in detergent tank for direct suction
- Automatic Stop System
- Ergonomic handle
- Accessory storage facility
- Standard set of accessories
- Fixed brush
- Inlet filter



Available also Wave UP 135 code 8.088.0004C  
135 bar max/420 l/h/1900 W with fixed brush and rotary brush

## Wave HR 135

- Three pistons, aluminium pump head with built-in by-pass valve
- Built-in detergent tank for direct suction
- Automatic Stop System
- Hose-reel
- Ergonomic handle
- Accessory storage facility
- Standard set of accessories
- Rotary brush
- Inlet filter



### COLD WATER HIGH-PRESSURE CLEANERS

code	8.088.0007C
barcode	8013298200146
max pressure (bar)	135
max delivery rate (l/h)	420
abs. power (W)	1900
weight (Kg)	8,7
dimensions (cm)	29,5 x 26,5 h 60
pcs for pallet	36

Load Q.ty: 20'=576 40'=1216 40' HC=1376

Available also 110/120V - 60Hz version: 1500 psi max - 1.55 GPM (USA) max - 1400W

### STANDARD EQUIPMENT





### Rise 110

- Three pistons, aluminium pump head with built-in by-pass valve
- Built-in detergent tank for direct suction
- Automatic Stop System
- Ergonomic handle
- Accessory storage facility
- Standard set of accessories
- Inlet filter



#### COLD WATER HIGH-PRESSURE CLEANERS

code	on request
barcode	-
max pressure bar	110
max delivery rate l/h	330
abs. power W	1700
weight	7,2 Kg
dimensions	29,5 x 26,5 h 54 cm
pcs for pallet	48

Load Q.ty: 20'=648 40'=1360 40' HC=1536

Available also 110/120V - 60Hz version: 1300 psi max - 1.35 GPM (USA) max - 1300W

#### STANDARD EQUIPMENT



Available also with induction motor, RS Extra model

#### STANDARD EQUIPMENT



#### COLD WATER HIGH-PRESSURE CLEANERS

code	8.090.0003C
barcode	8013298202508
max pressure bar	135
max delivery rate l/h	420
abs. power W	1900
weight	9,4 Kg
dimensions	29,5 x 40 h 55
pcs for pallet	24

Load Q.ty: 20'=436 40'=916 40' HC=1076

Available also 110/120V - 60Hz version: 1400 psi max - 1.55 GPM (USA) max - 1350W

### Rise UP 135

- Three pistons, aluminium pump head with built-in by-pass valve
- Built-in detergent tank for direct suction
- Automatic Stop System
- Ergonomic handle
- Accessory storage facility
- Standard set of accessories
- Rotary brush
- Patio cleaner
- Fixed brush
- Inlet filter



Available also with induction motor, RS Extra model



### Rise HR 145

- Three pistons, aluminium pump head with built-in by-pass valve
- Built-in detergent tank for direct suction
- Automatic Stop System
- Hose-reel
- Ergonomic handle
- Accessory storage facility
- Standard set of accessories
- Rotary brush
- Inlet filter



#### COLD WATER HIGH-PRESSURE CLEANERS

code	8.090.0013C
barcode	8013298203475
max pressure bar	145
max delivery rate l/h	450
abs. power W	2100
weight	10,2 Kg
dimensions	29,5 x 39,5 h 53 cm
pcs for pallet	32

Load Q.ty: 20'=436 40'=896 40' HC=1116

Available also 110/120V - 60Hz version: 1500 psi max - 1.55 GPM (USA) max - 1400W

#### STANDARD EQUIPMENT



Available also with induction motor, RS Extra model



## ARMY 110



- Three pistons, aluminium pump head with built-in by-pass valve
- Built-in detergent tank for direct suction
- Automatic Stop System
- Ergonomic handle
- Accessory storage facility
- Standard set of accessories
- Turbo lance
- Inlet filter



### COLD WATER HIGH-PRESSURE CLEANERS

code	8.088.0029C
barcode	8013298202720
max pressure (bar)	110
max delivery rate (l/h)	330
abs. power (W)	1700
weight (Kg)	7,7
packing dim. (cm)	29,5 x 26,5 h 60
pcs for pallet	36

Load Q.ty: 20'=576 40'=1216 40' HC=1376

Available also 110/120V - 60Hz version: 1300 psi max - 1.35 GPM (USA) max - 1300W

### STANDARD EQUIPMENT



### STANDARD EQUIPMENT



### COLD WATER HIGH-PRESSURE CLEANERS

code	8.088.0030C
barcode	8013298202737
max pressure (bar)	125
max delivery rate (l/h)	400
abs. power (W)	1800
weight (Kg)	8
packing dim. (cm)	29,5 x 26,5 h 60
pcs for pallet	36

Load Q.ty: 20'=576 40'=1216 40' HC=1376

Available also 110/120V - 60Hz version: 1400 psi max - 1.55 GPM (USA) max - 1350W

## MARINE 125

- Three pistons, aluminium pump head with built-in by-pass valve.
- Built-in detergent tank for direct suction
- Automatic Stop System
- Ergonomic handle
- Accessory storage facility
- Standard set of accessories
- Turbo lance
- Fixed brush
- Inlet filter



## FORCE 145



- Three pistons, aluminium pump head with built-in by-pass valve
- Automatic Stop System
- Hose-reel
- Ergonomic handle
- Accessory storage facility
- Standard set of accessories
- Rotary brush
- Inlet filter
- Patio cleaner
- Fixed brush



### COLD WATER HIGH-PRESSURE CLEANERS

code	8.088.0034C
barcode	8013298203444
max pressure (bar)	145
max delivery rate (l/h)	450
abs. power (W)	2100
weight (Kg)	9,8
packing dim. (cm)	29,5 x 39,5 h 58
pcs for pallet	24

Load Q.ty: 20'=432 40'=912 40' HC=1012

Available also 110/120V - 60Hz version: 1500 psi max - 1.55 GPM (USA) max - 1400W

### STANDARD EQUIPMENT





### Rise up 130 Blower

- Three pistons, aluminium pump head with built-in by-pass valve.
- Built-in detergent tank for direct suction
- Automatic Stop System
- Ergonomic handle
- Accessory storage facility
- Standard set of accessories
- Turbo lance
- Blower function (800 W)
- Inlet filter

**WITH BLOWER FUNCTION**



#### COLD WATER HIGH-PRESSURE CLEANERS WITH BLOWER FUNCTION

code	8.090.0019C
barcode	8013298205189
max pressure (bar)	130
max delivery rate (l/h)	420
abs. power (W)	1800
weight (Kg)	10,5
packing dim. (cm)	34 x 34 h 78
pcs for pallet	24

Load Q.ty: 20'=334 40'=694 40' HC=724

Available also 110/120V - 60Hz version: 1400 psi max - 1.55 GPM (USA) max - 1350W

#### STANDARD EQUIPMENT



#### STANDARD EQUIPMENT



#### COLD WATER HIGH-PRESSURE CLEANERS WITH STEAM CLEANER COMBINED

code	8.088.0019C
barcode	8013298201280
max pressure (bar)	130
max delivery rate (l/h)	420
abs. power (W)	1800
weight (Kg)	10,5
packing dim. (cm)	36 x 30 h 58
pcs for pallet	24

Load Q.ty: 20'=452 40'=932 40' HC=1088

Available also 110/120V - 60Hz version: 1400 psi max - 1.55 GPM (USA) max - 1350W

### Wave 130 Steam

- Three pistons, aluminium pump head with built-in by-pass valve.
- Built-in detergent tank for direct suction
- Automatic Stop System
- Ergonomic handle
- Accessory storage facility
- Standard set of accessories
- Turbo lance
- Steam generator unit
- Inlet filter

**WITH STEAM GENERATOR**



### STM 140 Compressor

- Three pistons, aluminium pump head with built-in by-pass valve
- Built-in detergent tank for direct suction
- Automatic Stop System
- Hose-holder
- Ergonomic handle
- Accessory storage facility
- Standard set of accessories
- Turbo lance
- Air compressor unit

**WITH AIR COMPRESSOR UNIT**



#### COLD WATER HIGH-PRESSURE CLEANERS WITH AIR COMPRESSOR UNIT

code	8.086.0033C
barcode	8013298201044
max pressure (bar)	140
max delivery rate (l/h)	450
abs. power (W)	2100
weight (Kg)	9,9
packing dim. (cm)	26 x 39 h 63
pcs for pallet	27

Load Q.ty: 20'=440 40'=905 40' HQ=1020

Available also 110/120V - 60Hz version: 1600 psi - 1.80 GPM (USA) - 1500W

#### STANDARD EQUIPMENT





**NEW**

## Predator 140

- Three pistons, aluminium pump head with built-in by-pass valve
- Built-in detergent tank for direct suction
- Automatic Stop System
- Hose-holder
- Ergonomic handle
- Accessory storage facility
- Standard set of accessories
- Turbo lance
- Rotary brush



### COLD WATER HIGH-PRESSURE CLEANERS

code	8.101.0018C
barcode	8013298211296
max pressure (bar)	140
max delivery rate (l/h)	450
abs. power (W)	1900
weight (Kg)	10,4
packing dim. (cm)	38 x 30 h 57
pcs for pallet	24

Load Q.ty: 20'=452 40'=932 40' HQ=1052

Available also 110/120V - 60Hz version: 1500 psi - 1.55 GPM (USA) - 1400W

### STANDARD EQUIPMENT



### STANDARD EQUIPMENT



### COLD WATER HIGH-PRESSURE CLEANERS

code	8.101.0019C
barcode	8013298211302
max pressure (bar)	150
max delivery rate (l/h)	450
abs. power (W)	2100
weight (Kg)	10,4
packing dim. (cm)	29,5 x 39,5 h 58
pcs for pallet	24

Load Q.ty: 20'=432 40'=912 40' HQ=1012

Available also 110/120V - 60Hz version: 1600 psi - 1.80 GPM (USA) - 1500W

## Predator 150

- Three pistons, aluminium pump head with built-in by-pass valve
- Built-in detergent tank for direct suction
- Automatic Stop System
- Hose-holder
- Ergonomic handle
- Accessory storage facility
- Standard set of accessories
- Turbo lance
- Rotary brush
- Patio cleaner



**NEW**



**NEW**

## Predator 160

- Three pistons, aluminium pump head with built-in by-pass valve
- Built-in detergent tank for direct suction
- Hose-reel
- Automatic Stop System
- Ergonomic handle
- Accessory storage facility
- Standard set of accessories
- Turbo lance
- Rotary brush
- Fixed brush
- Patio cleaner



### COLD WATER HIGH-PRESSURE CLEANERS

code	8.101.0020C
barcode	8013298211319
max pressure (bar)	160
max delivery rate (l/h)	510
abs. power (W)	2500
weight (Kg)	12,4
packing dim. (cm)	37 x 37 h 54
pcs for pallet	18

Load Q.ty: 20'=360 40'=744 40' HQ=870

Available also 110/120V - 60Hz version: 1800 psi - 1.90 GPM (USA) - 1600W

### STANDARD EQUIPMENT





### Space 150

- Three pistons, aluminium pump head with built-in by-pass valve
- Automatic Stop System
- Hose-holder
- Ergonomic handle
- Accessory storage facility
- Standard set of accessories
- Turbo lance



#### COLD WATER HIGH-PRESSURE CLEANERS

code	8.107.0005C
barcode	8013298207145
max pressure (bar)	150
max delivery rate (l/h)	450
abs. power (W)	2100
weight (Kg)	10
packing dim. (cm)	38 x 30 h 57
pcs for pallet	24

Load Q.ty: 20'=452 40'=932 40' HQ=1052

Available also 110/120V - 60Hz version: 1500 psi - 1.55 GPM (USA) - 1400W

#### STANDARD EQUIPMENT



#### STANDARD EQUIPMENT



#### COLD WATER HIGH-PRESSURE CLEANERS

code	8.107.0001C
barcode	8013298205196
max pressure (bar)	160
max delivery rate (l/h)	510
abs. power (W)	2500
weight (Kg)	10
packing dim. (cm)	30 x 38 h 57
pcs for pallet	24

Load Q.ty: 20'=452 40'=932 40' HQ=1052

Available also 110/120V - 60Hz version: 1600 psi - 1.80 GPM (USA) - 1500W

On request available also version with hose-reel in pressure

### Space 160

- Three pistons, aluminium pump head with built-in by-pass valve
- Built-in detergent tank for direct suction
- Automatic Stop System
- Hose-reel
- Ergonomic handle
- Accessory storage facility
- Standard set of accessories
- Turbo lance



### Space 180

- Three pistons, aluminium pump head with built-in by-pass valve
- Built-in detergent tank for direct suction
- Hose-reel
- Automatic Stop System
- Ergonomic handle
- Accessory storage facility
- Standard set of accessories
- Turbo lance
- Rotary brush
- Fixed brush
- Patio cleaner



#### COLD WATER HIGH-PRESSURE CLEANERS

code	8.107.0002C
barcode	8013298205363
max pressure (bar)	180
max delivery rate (l/h)	510
abs. power (W)	2500
weight (Kg)	11,6
packing dim. (cm)	37 x 37 h 54
pcs for pallet	18

Load Q.ty: 20'=360 40'=744 40' HQ=870

Available also 110/120 - 60Hz version: 1800 psi - 1.90 GPM (USA) - 1600W

On request available also version with hose-reel in pressure

#### STANDARD EQUIPMENT







**NEW**

## Epic 140

- Three pistons, aluminium pump head with built-in by-pass valve
- Automatic Stop System
- Hose-holder
- Ergonomic handle
- Accessory storage facility
- Standard set of accessories
- Turbo lance
- Rotary brush



### COLD WATER HIGH-PRESSURE CLEANERS

code	On request
barcode	-
max pressure (bar)	140
max delivery rate (l/h)	450
abs. power (W)	1900
weight (Kg)	10,4
packing dim. (cm)	38 x 30 h 57
pcs for pallet	24

Load Q.ty: 20'=452 40'=932 40' HQ=1052

Available also 110/120V - 60Hz version: 1500 psi - 1.55 GPM (USA) - 1400W

### STANDARD EQUIPMENT



### STANDARD EQUIPMENT



### COLD WATER HIGH-PRESSURE CLEANERS

code	On request
barcode	-
max pressure (bar)	150
max delivery rate (l/h)	450
abs. power (W)	2100
weight (Kg)	10,4
packing dim. (cm)	29,5 x 39,5 h 58
pcs for pallet	24

Load Q.ty: 20'=432 40'=912 40' HQ=1012

Available also 110/120V - 60Hz version: 1600 psi - 1.80 GPM (USA) - 1500W

## Epic 150

- Three pistons, aluminium pump head with built-in by-pass valve
- Automatic Stop System
- Hose-holder
- Ergonomic handle
- Accessory storage facility
- Standard set of accessories
- Turbo lance
- Rotary brush
- Patio cleaner



**NEW**

## Epic 160

**NEW**

- Three pistons, aluminium pump head with built-in by-pass valve
- Hose-reel
- Automatic Stop System
- Ergonomic handle
- Accessory storage facility
- Standard set of accessories
- Turbo lance
- Rotary brush
- Fixed brush
- Patio cleaner



### COLD WATER HIGH-PRESSURE CLEANERS

code	On request
barcode	-
max pressure (bar)	160
max delivery rate (l/h)	510
abs. power (W)	2500
weight (Kg)	12,4
packing dim. (cm)	37 x 37 h 54
pcs for pallet	18

Load Q.ty: 20'=360 40'=744 40' HQ=870

Available also 110/120V - 60Hz version: 1800 psi - 1.90 GPM (USA) - 1600W

### STANDARD EQUIPMENT





### Galaxy 140

- Three pistons, aluminium pump head with built-in by-pass valve
- Automatic Stop System
- Hose-holder
- Ergonomic handle
- Accessory storage facility
- Standard set of accessories
- Turbo lance
- Rotary brush



#### COLD WATER HIGH-PRESSURE CLEANERS

code	8.086.0077C
barcode	8013298203413
max pressure (bar)	140
max delivery rate (l/h)	450
abs. power (W)	1900
weight (Kg)	10,4
packing dim. (cm)	38 x 30 h 57
pcs for pallet	24

Load Q.ty: 20'=452 40'=932 40' HQ=1052

Available also 110/120V - 60Hz version: 1500 psi - 1.55 GPM (USA) - 1400W

#### STANDARD EQUIPMENT



#### STANDARD EQUIPMENT



#### COLD WATER HIGH-PRESSURE CLEANERS

code	8.086.0075C
barcode	8013298203277
max pressure (bar)	150
max delivery rate (l/h)	450
abs. power (W)	2100
weight (Kg)	10,4
packing dim. (cm)	29,5 x 39,5 h 58
pcs for pallet	24

Load Q.ty: 20'=432 40'=912 40' HQ=1012

Available also 110/120V - 60Hz version: 1600 psi - 1.80 GPM (USA) - 1500W

### Galaxy 150

- Three pistons, aluminium pump head with built-in by-pass valve
- Automatic Stop System
- Hose-holder
- Ergonomic handle
- Accessory storage facility
- Standard set of accessories
- Turbo lance
- Rotary brush
- Patio cleaner



### Galaxy 160

- Three pistons, aluminium pump head with built-in by-pass valve
- Hose-reel
- Automatic Stop System
- Ergonomic handle
- Accessory storage facility
- Standard set of accessories
- Turbo lance
- Rotary brush
- Fixed brush
- Patio cleaner



#### COLD WATER HIGH-PRESSURE CLEANERS

code	8.086.0076C
barcode	8013298203406
max pressure (bar)	160
max delivery rate (l/h)	510
abs. power (W)	2500
weight (Kg)	12,4
packing dim. (cm)	37 x 37 h 54
pcs for pallet	18

Load Q.ty: 20'=360 40'=744 40' HQ=870

Available also 110/120 - 60Hz version: 1800 psi - 1.90 GPM (USA) - 1600W

#### STANDARD EQUIPMENT





**NEW**

## Stargate 150

- Three pistons, aluminium pump head with built-in by-pass valve
- Automatic Stop System
- Hose-holder
- Ergonomic handle
- Accessory storage facility
- Standard set of accessories
- Turbo lance



### COLD WATER HIGH-PRESSURE CLEANERS

code	8.107.0040C
barcode	8013298211777
max pressure (bar)	150
max delivery rate (l/h)	450
abs. power (W)	2100
weight (Kg)	10
packing dim. (cm)	38 x 30 h 57
pcs for pallet	24

Load Q.ty: 20'=452 40'=932 40' HQ=1052

Available also 110/120V - 60Hz version: 1500 psi - 1.55 GPM (USA) - 1400W

### STANDARD EQUIPMENT



### STANDARD EQUIPMENT



### COLD WATER HIGH-PRESSURE CLEANERS

code	8.107.0039C
barcode	8013298211760
max pressure (bar)	160
max delivery rate (l/h)	510
abs. power (W)	2500
weight (Kg)	10
packing dim. (cm)	30 x 38 h 57
pcs for pallet	24

Load Q.ty: 20'=452 40'=932 40' HQ=1052

Available also 110/120V - 60Hz version: 1600 psi - 1.80 GPM (USA) - 1500W

On request available also version with hose-reel in pressure

## Stargate 160

- Three pistons, aluminium pump head with built-in by-pass valve
- Automatic Stop System
- Hose-reel
- Ergonomic handle
- Accessory storage facility
- Standard set of accessories
- Turbo lance
- Built-in detergent tank for direct suction



**NEW**

**NEW**

## Stargate 180

- Three pistons, aluminium pump head with built-in by-pass valve
- Built-in detergent tank for direct suction
- Hose-reel
- Automatic Stop System
- Ergonomic handle
- Accessory storage facility
- Standard set of accessories
- Turbo lance
- Rotary brush
- Fixed brush
- Patio cleaner



### COLD WATER HIGH-PRESSURE CLEANERS

code	8.107.0041C
barcode	8013298211784
max pressure (bar)	180
max delivery rate (l/h)	510
abs. power (W)	2500
weight (Kg)	11,6
packing dim. (cm)	37 x 37 h 54
pcs for pallet	18

Load Q.ty: 20'=360 40'=744 40' HQ=870

Available also 110/120V - 60Hz version: 1800 psi - 1.90 GPM (USA) - 1600W

On request available also version with hose-reel in pressure

### STANDARD EQUIPMENT





### STM 140

- Three pistons, aluminium pump head with built-in by-pass valve
- Automatic Stop System
- Hose-holder
- Ergonomic handle
- Accessory storage facility
- Standard set of accessories
- Turbo lance
- Rotary brush



#### COLD WATER HIGH-PRESSURE CLEANERS

code	8.086.0001C
barcode	8013298168941
max pressure (bar)	140
max delivery rate (l/h)	450
abs. power (W)	1900
weight (Kg)	8,9
packing dim. (cm)	59,5 x 26,5 h 31
pcs for pallet	36

Load Q.ty: 20'=567 40'=1190 40' HQ=1360

Available also 110/120V - 60Hz version: 1500 psi - 1.55 GPM (USA) - 1400W

#### STANDARD EQUIPMENT



#### STANDARD EQUIPMENT



#### COLD WATER HIGH-PRESSURE CLEANERS

code	8.086.0078C
barcode	8013298203451
max pressure (bar)	150
max delivery rate (l/h)	450
abs. power (W)	2100
weight (Kg)	10,1
packing dim. (cm)	29,5 x 39,5 h 58
pcs for pallet	24

Load Q.ty: 20'=432 40'=912 40' HQ=1012

Available also 110/120V - 60Hz version: 1600 psi - 1.80 GPM (USA) - 1500W

### STM 150

- Three pistons, aluminium pump head with built-in by-pass valve
- Automatic Stop System
- Hose-holder
- Ergonomic handle
- Accessory storage facility
- Standard set of accessories
- Turbo lance
- Rotary brush
- Patio cleaner



### STM 160

- Three pistons, aluminium pump head with built-in by-pass valve
- Hose-reel
- Automatic Stop System
- Ergonomic handle
- Accessory storage facility
- Standard set of accessories
- Turbo lance
- Rotary brush
- Fixed brush
- Patio cleaner



#### COLD WATER HIGH-PRESSURE CLEANERS

code	8.086.0003C
barcode	8013298168965
max pressure (bar)	160
max delivery rate (l/h)	510
abs. power (W)	2500
weight (Kg)	12,4
packing dim. (cm)	37 x 37 h 54
pcs for pallet	18

Load Q.ty: 20'=360 40'=744 40' HQ=870

Available also 110/120 - 60Hz version: 1800 psi - 1.90 GPM (USA) - 1600W

#### STANDARD EQUIPMENT





High pressure cleaner with patented **Washing Program System**, offering the most suited washing program for each cleaning task.

**PLUS:**

- **Variable performances & connected load:** Motor & pump variable speed, flow rate and operating pressure adjustment without efficiency loss. **Maximized water and energy saving for each cleaning task**
- **Longer motor life:** Slow & progressive motor spinning start. No current peaks, less sparks and mechanical stress inside the motor. **Extended product working life – higher value for money**
- **Working mode setting:** Solid rotative selector on the unit with 3 pre-set washing programs **simple selection of extensive tailored performances**

## SELECT YOUR PROGRAM

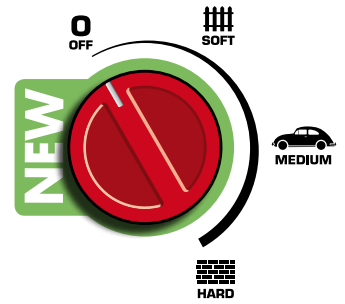

PROGRAM <b>SOFT</b>	<b>-50%</b> Energy saving	GARDEN FURNITURE, SURFACES, BICYCLES, PLASTERS...
PROGRAM <b>MEDIUM</b>	<b>-25%</b> Energy saving	CARS, MOTORBIKES, CARAVANS, PLASTERED WALLS...
PROGRAM <b>HARD</b>	<b>100%</b> Power	METAL RAILINGS, GARDEN TOOLS, BRICKS, TERRACES...

**STANDARD EQUIPMENT**



**COLD WATER HIGH-PRESSURE CLEANERS**

code	8.092.0080C
barcode	8013298211135
max pressure (bar)	145
max delivery rate (l/h)	420
abs. power (W)	1900
weight (Kg)	8,5
packing dim. (cm)	39,5 x 29 h 54
pcs for pallet	32

Load Q.ty: 20'=452 40'=932 40' HC=1052

Available also 110/120 - 60Hz version

## NJ Plus 145 WPS

- Three pistons, aluminium pump head with built-in by-pass valve
- Automatic Stop System
- Washing Program System
- Hose-holder
- Accessory storage facility
- Ergonomic handle
- Turbo lance
- Rotary brush
- Fixed brush
- Patio cleaner



**PATENTED**



**NEW**

## Predator 160 WPS

**COLD WATER HIGH-PRESSURE CLEANERS**

code	8.101.0017C
barcode	8013298211142
max pressure (bar)	160
max delivery rate (l/h)	510
abs. power (W)	2500
weight (Kg)	15,5
packing dim. (cm)	37 x 37 h 56
pcs for pallet	18

Load Q.ty: 20'=452 40'=932 40' HC=1052

**PATENTED**

Available also 110/120 - 60Hz version

**STANDARD EQUIPMENT**





**NEW**

### Epic 160 WPS

- Three pistons, aluminium pump head with built-in by-pass valve
- Automatic Stop System
- Washing Program System
- Hose-reel
- Ergonomic handle
- Accessory storage facility
- Standard set of accessories
- Turbo lance
- Rotary brush



#### COLD WATER HIGH-PRESSURE CLEANERS

code	On request
barcode	-
max pressure (bar)	160
max delivery rate (l/h)	510
abs. power (W)	2500
weight (Kg)	12,4
packing dim. (cm)	37 x 37 h 54
pcs for pallet	18

Load Q.ty: 20'=567 40'=1190 40' HQ=1360

Available also 110/120V - 60Hz version: 1500 psi - 1.55 GPM (USA) - 1400W

#### STANDARD EQUIPMENT



#### STANDARD EQUIPMENT



#### COLD WATER HIGH-PRESSURE CLEANERS

code	8.086.0140C
barcode	8013298207411
max pressure (bar)	160
max delivery rate (l/h)	510
abs. power (W)	2500
weight (Kg)	12,4
packing dim. (cm)	38 x 30 h 57
pcs for pallet	24

Load Q.ty: 20'=452 40'=932 40' HC=1052

Available also 110/120 - 60Hz version

### STM 160 WPS

- Three pistons, aluminium pump head with built-in by-pass valve
- Hose-reel
- Automatic Stop System
- Washing Program System
- Ergonomic handle
- Accessory storage facility
- Standard set of accessories
- Rotary brush

**PATENTED**



### Planet 160 WPS

- Three pistons, aluminium pump head with built-in by-pass valve
- Hose-reel
- Automatic Stop System
- Washing Program System
- Ergonomic handle
- Accessory storage facility
- Standard set of accessories
- Rotary brush



#### COLD WATER HIGH-PRESSURE CLEANERS

code	On request
barcode	-
max pressure (bar)	160
max delivery rate (l/h)	510
abs. power (W)	2500
weight (Kg)	12,4
packing dim. (cm)	38 x 30 h 57
pcs for pallet	24

Load Q.ty: 20'=452 40'=932 40' HC=1052

Available also 110/120 - 60Hz version

#### STANDARD EQUIPMENT



# Predator 180 Digit

COLD WATER HIGH-PRESSURE CLEANERS WITH DIGITAL CONTROL SYSTEM

**NEW**

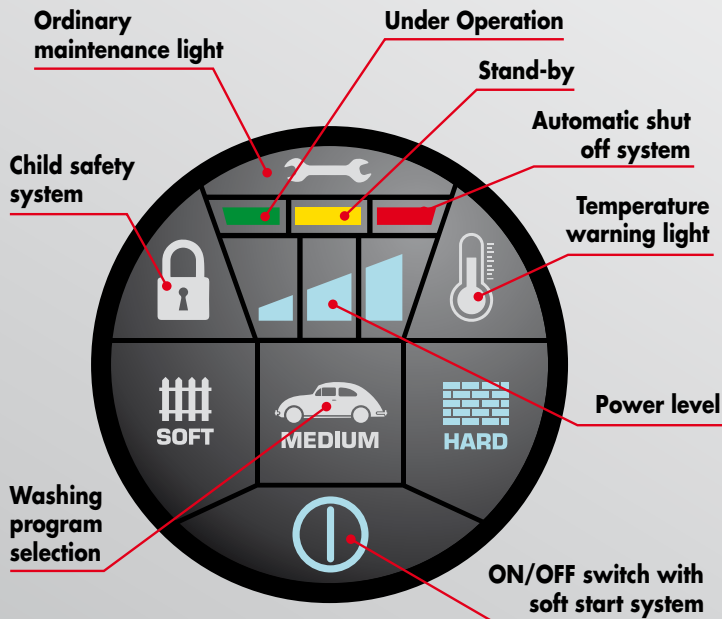

**PATENTED**



88  
28  
Cm  
28

## STANDARD EQUIPMENT



- Three pistons, aluminium pump head with built-in by-pass valve
- Built-in detergent tank for direct suction
- Hose-reel
- Automatic Stop System
- Digital Control System
- Washing Program System
- Ergonomic handle
- Accessory storage facility
- Standard set of accessories
- Rotary brush
- Fixed brush

## COLD WATER HIGH-PRESSURE CLEANERS

code	8.101.0024C
barcode	8013298211463
max pressure (bar)	180
max delivery rate (l/h)	510
abs. power (W)	2500
weight (Kg)	15,8
packing dim. (cm)	37 x 37 h 56
pcs for pallet	18

Load Q.ty: 20'=452 40'=932 40' HC=1052





### Prime 155

- Three pistons, aluminium pump head with built-in by-pass valve
- Built-in detergent tank for direct suction
- Hose-reel
- Automatic Stop System
- Ergonomic handle
- Accessory storage facility
- Standard set of accessories
- Turbo lance
- Rotary brush
- Patio cleaner



#### COLD WATER HIGH-PRESSURE CLEANERS

code	8.097.0001C
barcode	8013298202430
max pressure (bar)	155
max delivery rate (l/h)	450
abs. power (W)	2100
weight (Kg)	15
packing dim. (cm)	40,5 x 40,5 h 70
pcs for pallet	18

Load Q.ty: 20'=210 40'=460 40' HQ=547

Available also 110/120V - 60Hz version: 1600 psi max - 1.80 GPM (USA) max - 1500W

#### STANDARD EQUIPMENT



#### STANDARD EQUIPMENT



#### COLD WATER HIGH-PRESSURE CLEANERS

code	8.097.0002C
barcode	8013298202447
max pressure (bar)	165
max delivery rate (l/h)	510
abs. power (W)	2500
weight (Kg)	15,6
packing dim. (cm)	40,5 x 40,5 h 70
pcs for pallet	18

Load Q.ty: 20'=210 40'=460 40' HQ=547

Available also 110/120V - 60Hz version: 1800 psi max - 1.90 GPM (USA) max - 1600W

### Prime 165

- Three pistons, aluminium pump head with built-in by-pass valve
- Built-in detergent tank for direct suction
- Hose-reel
- Automatic Stop System
- Ergonomic handle
- Accessory storage facility
- Standard set of accessories
- Turbo lance
- Rotary brush
- Patio cleaner
- Pipe cleaning hose 6 m.







## Ikon 140

- Low maintenance motor
- Three pistons, aluminium pump head with built-in by-pass valve
- Automatic Stop System
- Hose-holder
- Ergonomic handle
- Accessory storage facility
- Standard set of accessories
- Turbo lance

80  
29  
Cm  
31

**BRUSHLESS  
INDUCTION  
MOTOR POWERED**

### COLD WATER HIGH-PRESSURE CLEANERS

code	8.108.0001C
barcode	8013298205769
max pressure (bar)	140
max delivery rate (l/h)	360
abs. power (W)	2000
weight (Kg)	14,5
packing dim. (cm)	38 x 30 h 57
pcs for pallet	24

Q.ty: 20'=308 40'=672 40' HQ=768  
Floor loaded not available.

### STANDARD EQUIPMENT



### STANDARD EQUIPMENT COLD WATER HIGH-PRESSURE CLEANERS



code	8.108.0006C
barcode	8013298207893
max pressure (bar)	160
max delivery rate (l/h)	390
abs. power (W)	2200
weight (Kg)	15,5
packing dim. (cm)	38 x 30 h 57
pcs for pallet	24

Q.ty: 20'=308 40'=672 40' HQ=768  
Floor loaded not available.



**BRUSHLESS  
INDUCTION  
MOTOR POWERED**

## Ikon 160 Plus

- Low maintenance motor
- Three pistons, aluminium pump head with built-in by-pass valve
- Built-in detergent tank for direct suction
- Automatic Stop System
- Hose-reel in pressure
- Ergonomic handle
- Accessory storage facility
- Turbo lance

**With hose-reel  
in pressure**

80  
29  
Cm  
31



• Available also without hose reel in pressure 8.108.0002C



## Ikon 200 EXTREME

- Low maintenance motor
- Three pistons, aluminium pump head with built-in by-pass valve
- Built-in detergent tank for direct suction
- Automatic Stop System
- Hose-reel in pressure
- Ergonomic handle
- Accessory storage facility
- Professional hose
- Set 4 nozzles
- Turbo lance

80  
29  
Cm  
31

**With hose-reel  
in pressure**

**BRUSHLESS  
INDUCTION  
MOTOR POWERED**

### COLD WATER HIGH-PRESSURE CLEANERS

code	8.108.0021C
barcode	8013298209446
max pressure (bar)	200
max delivery rate (l/h)	300
abs. power (W)	2300
weight (Kg)	18
packing dim. (cm)	38 x 30 h 57
pcs for pallet	24

Q.ty: 20'=308 40'=672 40' HC=768  
Floor loaded not available.

### STANDARD EQUIPMENT





**NEW**

### Cruiser 140

- Low maintenance motor
- Three pistons, aluminium pump head with built-in by-pass valve
- Automatic Stop System
- Hose-holder
- Ergonomic handle
- Accessory storage facility
- Standard set of accessories
- Turbo lance



**BRUSHLESS  
INDUCTION  
MOTOR POWERED**

#### COLD WATER HIGH-PRESSURE CLEANERS

code	8.108.0046C
barcode	8013298211791
max pressure (bar)	140
max delivery rate (l/h)	360
abs. power (W)	2000
weight (Kg)	14,5
packing dim. (cm)	38 x 30 h 57
pcs for pallet	24

Q.ty: 20'=308 40'=672 40' HQ=768  
Floor loaded not available.

#### STANDARD EQUIPMENT



#### STANDARD EQUIPMENT COLD WATER HIGH-PRESSURE CLEANERS



code	8.108.0047C
barcode	8013298211807
max pressure (bar)	160
max delivery rate (l/h)	390
abs. power (W)	2200
weight (Kg)	15,5
packing dim. (cm)	38 x 30 h 57
pcs for pallet	24

Q.ty: 20'=308 40'=672 40' HQ=768  
Floor loaded not available.



**BRUSHLESS  
INDUCTION  
MOTOR POWERED**

### Cruiser 160 Plus

- Low maintenance motor
- Three pistons, aluminium pump head with built-in by-pass valve
- Built-in detergent tank for direct suction
- Automatic Stop System
- Hose-reel in pressure
- Ergonomic handle
- Accessory storage facility
- Turbo lance

**With hose-reel  
in pressure**



**NEW**



**NEW**

### Cruiser 200 EXTREME

- Low maintenance motor
- Three pistons, aluminium pump head with built-in by-pass valve
- Built-in detergent tank for direct suction
- Automatic Stop System
- Hose-reel in pressure
- Ergonomic handle
- Accessory storage facility
- Professional hose
- Set 4 nozzles
- Turbo lance



**With hose-reel  
in pressure**

**BRUSHLESS  
INDUCTION  
MOTOR POWERED**

#### COLD WATER HIGH-PRESSURE CLEANERS

code	8.108.0048C
barcode	8013298211838
max pressure (bar)	200
max delivery rate (l/h)	300
abs. power (W)	2300
weight (Kg)	18
packing dim. (cm)	38 x 30 h 57
pcs for pallet	24

Q.ty: 20'=308 40'=672 40' HC=768  
Floor loaded not available.

#### STANDARD EQUIPMENT



## Hero 105 AC

COLD WATER HIGH-PRESSURE CLEANERS

STANDARD EQUIPMENT



- Low maintenance motor
- Three pistons, aluminium pump head with built-in by-pass valve
- Orientable jet nozzle head
- Automatic Stop System
- Standard set of accessories
- Ergonomic handle

**BRUSHLESS  
INDUCTION  
MOTOR POWERED**

code	On request
barcode	-
max pressure (bar)	90
max delivery rate (l/h)	300
abs. power (W)	850
weight (Kg)	6
packing dim. (cm)	40 x25,5 h 31
pcs for pallet	60

Load Q.ty: 20'=660 40'=1440 40' HC=1680  
Floor loaded not available.

Available also 110 /120V - 60Hz version:



STANDARD EQUIPMENT

COLD WATER HIGH-PRESSURE CLEANERS

## Hero 105



code	8.111.0001C
barcode	8013298208654
max pressure (bar)	105
max delivery rate (l/h)	300
abs. power (W)	850
weight (Kg)	6
packing dim. (cm)	40 x25,5 h 31
pcs for pallet	60

Load Q.ty: 20'=660 40'=1440 40' HC=1680  
Floor loaded not available.

Available also 110 /120V - 60Hz version:

- Low maintenance motor
- Three pistons, aluminium pump head with built-in by-pass valve
- Automatic Stop System
- Standard set of accessories
- Ergonomic handle

**BRUSHLESS  
INDUCTION  
MOTOR POWERED**



## Split 120

COLD WATER HIGH-PRESSURE CLEANERS

STANDARD EQUIPMENT



- Low maintenance motor
- Three pistons, aluminium pump head with built-in by-pass valve
- Automatic Stop System
- Ergonomic handle
- Standard set of accessories
- External detergent suction probe

**BRUSHLESS  
INDUCTION  
MOTOR POWERED**

code	8.104.0001C
barcode	8013298204441
max pressure (bar)	120
max delivery rate (l/h)	360
abs. power (W)	1800
weight (Kg)	12
packing dim. (cm)	40 x 24 h 33
pcs for pallet	60

Load Q.ty: 20'=660 40'=1440 40' HC=1680  
Floor loaded not available.

Available also 110/120V - 60Hz version: 1800 psi - 1.6 GPM (USA) - 1600W





### COLD WATER HIGH-PRESSURE CLEANERS

code	8.104.0005C
barcode	8013298205219
max pressure (bar)	140
max delivery rate (l/h)	390
abs. power (W)	2200
weight (Kg)	18,30
packing dim. (cm)	60 x 37 h 47,5
pcs for pallet	24

Q.ty: 20'=216 40'=480 40' HC=600  
Floor loaded not available.

Available also 110 /120V - 60Hz version: 1700 psi  
- 1.5 GPM (USA) - 1500W



## Rhino 140

- Low maintenance motor
- Three pistons, aluminium pump head with built-in by-pass valve
- Automatic Stop System
- Hose-holder
- External detergent suction probe
- Accessory storage facility
- Standard set of accessories
- Turbo lance

### STANDARD EQUIPMENT



**BRUSHLESS  
INDUCTION  
MOTOR POWERED**

### STANDARD EQUIPMENT



## Rhino 150

- Low maintenance motor
- Three pistons, aluminium pump head with built-in by-pass valve
- Automatic Stop System
- External detergent suction probe
- Hose-reel
- Ergonomic handle
- Accessory storage facility
- Turbo lance

### COLD WATER HIGH-PRESSURE CLEANERS

code	8.104.0004C
barcode	8013298205059
max pressure (bar)	150
max delivery rate (l/h)	390
abs. power (W)	2200
weight (Kg)	19,40
packing dim. (cm)	60 x 37 h 47,5
pcs for pallet	24

Q.ty: 20'=216 40'=480 40' HC=600  
Floor loaded not available.

Available also 110/120V - 60Hz version: 1800 psi  
- 1.6 GPM (USA) - 1600W



**BRUSHLESS  
INDUCTION  
MOTOR POWERED**



### COLD WATER HIGH-PRESSURE CLEANERS

code	8.047.0001C
barcode	8013298201198
max pressure (bar)	150
max delivery rate (l/h)	400
abs. power (W)	2200
weight (Kg)	17
packing dim. (cm)	40,5 x 40,5 h 60
pcs for pallet	18

Q.ty: 20'=198 40'=432 40' HC=576  
Floor loaded not available.



## Vertigo 22

- Low maintenance motor
- Three pistons, aluminium pump head with built-in by-pass valve
- Built-in detergent tank for direct suction
- Automatic Stop System
- Hose-holder
- Accessory storage facility
- Standard set of accessories
- Turbo lance
- Fixed brush

### STANDARD EQUIPMENT



**NEW**



## Vertigo 26

- Low maintenance motor
- Three pistons, aluminium pump head with built-in by-pass valve
- Automatic Stop System
- Built-in detergent tank for direct suction
- Hose-holder
- Accessory storage facility
- Standard set of accessories

### COLD WATER HIGH-PRESSURE CLEANERS

code	8.047.0071C
barcode	8013298211852
max pressure (bar)	170
max delivery rate (l/h)	530
abs. power (W)	2600
weight (Kg)	23
packing dim. (cm)	40,5 x 40,5 h 60
pcs for pallet	18

Q.ty: 20'=198 40'=432 40' HC=576  
Floor loaded not available.

### STANDARD EQUIPMENT



**BRUSHLESS  
INDUCTION  
MOTOR POWERED**



### STANDARD EQUIPMENT



### COLD WATER HIGH-PRESSURE CLEANERS

code	8.047.0003C
barcode	8013298201211
max pressure (bar)	180
max delivery rate (l/h)	510
abs. power (W)	2800
weight (Kg)	23,5
packing dim. (cm)	40,5 x 40,5 h 60
pcs for pallet	18

Q.ty: 20'=198 40'=432 40' HC=576  
Floor loaded not available.

## Vertigo 28

- Low maintenance motor
- Three pistons, **anodized pump head** with built-in by-pass valve
- Built-in detergent tank for direct suction
- Automatic Stop System
- Hose-reel in pressure
- Accessory storage facility
- Turbo lance
- Fixed brush
- Rotary brush
- Set of 4 nozzles



**BRUSHLESS  
INDUCTION  
MOTOR POWERED**



**NEW**



## Vertigo 28 PRO

- Low maintenance motor
- Three pistons, **brass pump head** with built-in by-pass valve
- Automatic Stop System
- Built-in detergent tank for direct suction
- Professional hose
- Hose-reel in pressure
- Accessory storage facility
- Standard set of accessories
- Turbo lance

### COLD WATER HIGH-PRESSURE CLEANERS

code	8.047.0068C
barcode	8013298211531
max pressure (bar)	180
max delivery rate (l/h)	510
abs. power (W)	2800
weight (Kg)	25
packing dim. (cm)	40,5 x 40,5 h 60
pcs for pallet	18

Q.ty: 20'=198 40'=432 40' HC=576  
Floor loaded not available.

### STANDARD EQUIPMENT



**BRUSHLESS  
INDUCTION  
MOTOR POWERED**





## High pressure cleaners with combustion engine

Lavor has a complete range of high pressure cleaners with combustion engine, ideal in areas where it is not possible the connection to the electric system.

The whole Independent, Lander range is an essential tool for hard tasks like for example washing vehicles, external areas, degreasing surfaces.

### STANDARD EQUIPMENT



## Independent 1900

- Unleaded gasoline engine
- Three pistons, aluminium pump head
- Accessory holder
- Hose-holder
- Ergonomic handle
- Standard set of accessories

### COLD WATER HIGH-PRESSURE CLEANERS WITH PETROL ENGINE

code	8.601.0103C
barcode	8013298166541
max pressure (bar)	130
max delivery rate (l/h)	520
RPM	3600 - 4 stroke
motor power (hp)	2,5
weight (Kg)	17,3
packing dim. (cm)	48 x 38,5 h 50,5
pcs for pallet	24

Q.ty: 20'=216 40'=480 40' HC=480  
Floor loaded not available.



## Marshall 2300

- Unleaded gasoline engine
- Three pistons, aluminium pump head
- Accessory holder
- Hose-holder
- Ergonomic handle
- Standard set of accessories
- Professional hose
- Set 5 nozzles

### COLD WATER HIGH-PRESSURE CLEANERS WITH PETROL ENGINE

code	8.601.0178C
barcode	8013298202966
max pressure (bar)	160
max delivery rate (l/h)	480
RPM	3600 - 4 stroke
motor power (hp)	5
weight (Kg)	29,5
packing dim. (cm)	60 x 49 h 58
pcs for pallet	12

Q.ty: 20'=108 40'=240 40' HC=320  
Floor loaded not available.

### STANDARD EQUIPMENT





## Independent 2300

- Unleaded gasoline engine
- Three pistons, aluminium pump head
- Accessory holder
- Professional hose
- Hose-holder
- Ergonomic handle
- Standard set of accessories
- Professional hose
- 3 mt garden hose
- Set 5 nozzles



### COLD WATER HIGH-PRESSURE CLEANERS WITH PETROL ENGINE

code	8.601.0151C
barcode	8013298166992
max pressure (bar)	160
max delivery rate (l/h)	540
RPM	3600 - 4 stroke
motor power (hp)	5,5
weight (Kg)	35
packing dim. (cm)	47 x 57 h 57
pcs for pallet	16

On pallet Q.ty: 20'=108 40'=240 40' HC=320

### STANDARD EQUIPMENT



### STANDARD EQUIPMENT



### COLD WATER HIGH-PRESSURE CLEANERS WITH PETROL ENGINE

code	8.601.0189C
barcode	8013298205455
max pressure (bar)	200
max delivery rate (l/h)	600
RPM	3600 - 4 stroke
motor power (hp)	6,5
weight (Kg)	37
packing dim. (cm)	47 x 57 h 57
pcs for pallet	16

Q.ty: 20'=108 40'=240 40' HC=320  
Floor loaded not available.

## Independent 2700

- Unleaded gasoline engine
- Easy start system
- Three pistons, aluminium pump head
- Accessory holder
- Professional hose
- Hose-holder
- Ergonomic handle
- Standard set of accessories
- Set 5 nozzles



## Independent 2800

- Unleaded gasoline engine
- Three pistons, **brass pump head**
- Accessory holder
- Hose-holder
- Professional hose
- Ergonomic handle
- Standard set of accessories
- Professional hose
- 3 mt garden hose
- Set 5 nozzles



### COLD WATER HIGH-PRESSURE CLEANERS WITH PETROL ENGINE

code	8.601.0148C
barcode	8013298169528
max pressure (bar)	200
max delivery rate (l/h)	690
RPM	3600 - 4 stroke
motor power (hp)	6,5
weight (Kg)	37
packing dim. (cm)	47 x 57 h 57
pcs for pallet	16

Q.ty: 20'=108 40'=240 40' HC=320  
Floor loaded not available.

### STANDARD EQUIPMENT





**NEW**

### Lander 2800

- Unleaded gasoline engine
- Easy start system
- Built-in detergent tank for direct suction
- Three pistons, aluminium pump head
- Accessory holder
- Hose-holder
- Professional hose
- Ergonomic handle
- Standard set of accessories
- Set 3 nozzles

#### COLD WATER HIGH-PRESSURE CLEANERS WITH PETROL ENGINE

code	8.601.0201C
barcode	8013298208715
max pressure (bar)	200
max delivery rate (l/h)	690
RPM	3600 - 4 stroke
motor power (hp)	6,5
weight (Kg)	30,5
packing dim. (cm)	55 x 53 h 59
pcs for pallet	12

Q.ty: 20'=120 40'=264 40' HC=352  
Floor loaded not available.

#### STANDARD EQUIPMENT



#### STANDARD EQUIPMENT



#### COLD WATER HIGH-PRESSURE CLEANERS WITH PETROL ENGINE

code	8.601.0202C
barcode	8013298208739
max pressure (bar)	210
max delivery rate (l/h)	690
RPM	3600 - 4 stroke
motor power (hp)	6,5
weight (Kg)	32
packing dim. (cm)	55 x 53 h 59
pcs for pallet	12

Q.ty: 20'=120 40'=264 40' HC=352  
Floor loaded not available.



### Lander 3000

- Unleaded gasoline engine
- Three pistons, **brass pump head**
- Accessory holder
- Built-in detergent tank for direct suction
- Hose-holder
- Professional hose
- Ergonomic handle
- Standard set of accessories
- Professional hose
- 3 mt garden hose
- Set 3 nozzles



**NEW**





**Blister pack accessories**

For all cold water high pressure cleaners, except Ikon 200 extreme, Cruiser 200 extreme, Marshall 2300, Independent 2300/2700/2800, Lander 2800/3000

	Code	Description	
	On request	Adjustable pressure lance	
	On request	High pressure curved lance - jet angle 30°	
	<b>NEW</b> 6.002.0384	High pressure curved nozzle head - jet angle 180°	
	On request	Water suction kit	
	On request	Brush for car rims washing	
	On request	Fixed brush	
	On request	Fixed soft brush	
	<b>NEW</b> On request	Fixed brush	
	<b>NEW</b> On request	T-Fixed brush	
	On request	Rotary brush	
	<b>NEW</b> On request	Articulated rotary brush	
	<b>NEW</b> 6.002.0660	Foam system with double regulation: jet size and detergent quantity	

## Patio cleaner boxed Ø 28



Patio cleaner with full colour box **cod. 6.008.0249C** For all cold water high pressure cleaners, except Ikon 200 extreme, Cruiser 200 extreme, Marshall 2300, Independent 2300/2700/2800, Lander 2800/3000

## Patio cleaner boxed Ø 25 with 4 adapter



Patio cleaner with full colour box **cod. 6.008.0273C** For all cold water high pressure cleaners, except Ikon 200 extreme, Cruiser 200 extreme, Marshall 2300, Independent 2300/2700/2800, Lander 2800/3000



## DVC 12 PT

### WET & DRY VACUUM CLEANERS

### STANDARD EQUIPMENT



- Silenced motor.
- Double electrical insulation.
- Suction system with by-pass cooling.
- Accessory storage facility.
- Plastic tank.
- 4 pivoting wheels.
- Flex hose 1.5 m with valve.
- Cloth filter.
- Power cable 4 m.

code	8.251.0003C
barcode	8013298066698
Power W	1000 (max 1200)
Column depress. mbar/kPa	170/17
Tank capacity l.	12
Suction air l/s	40
weight (Kg)	4,5
packing dim. (cm)	36 x 36 h 34
pcs for pallet	54

Load Q.ty: 20'=576 40'=1152 40' HC=1344



### STANDARD EQUIPMENT



### WET & DRY VACUUM CLEANERS

## DVC 20 XT



code	8.251.0001C
barcode	8013298066605
Power W	1200 (max 1400)
Column depress. mbar/kPa	180/18
Tank capacity l.	20
Suction air l/s	40
weight (Kg)	5,1
packing dim. (cm)	38,5 x 38,5 h 34
pcs for pallet	30

Load Q.ty: 20'=540 40'=1080 40' HC=1260

- Silenced motor.
- Double electrical insulation.
- Suction system with by-pass cooling.
- Accessory storage facility.
- Stainless steel tank.
- Power cable holder.
- 4 pivoting wheels.
- Flex hose 1.5 m with valve.
- Washable filter.
- Power cable 4 m.
- Electrostatic shock inhibitor



Available also **DVC 30 XT**, 30 l. tank capacity, on request



## LVC 20 XS

### WET & DRY VACUUM CLEANERS

### STANDARD EQUIPMENT



- Silenced motor.
- Double electrical insulation.
- Suction system with by-pass cooling.
- **Filter cleaning system**
- Accessory storage facility.
- Stainless steel tank.
- Power cable holder.
- 4 pivoting wheels.
- Flex hose 2.5 m with valve.
- Washable filter.
- Power cable 4,5 m.

code	0.063.0001C
barcode	8013298040827
Power W	1200 (max 1400)
Column depress. mbar/kPa	180/18
Tank capacity l.	20
Suction air l/s	45
weight (Kg)	7,7
packing dim. (cm)	43,5 x 37 h 59
pcs for pallet	N.A

Load Q.ty: 20'=304 40' - 40' HC=738



Available also **LVC 30 XS**, 30 l. tank capacity, code 0.063.0002C

## Being Manufacturers: from experience to knowledge

In the high-pressure cleaners market companies are divided in those who buy components to assemble products and manufacturers, who have a continuous R&D on all product components.

Lavor manufactures all high-pressure cleaners components entirely and this allows: to spread product knowledge, culture and experience inside the company; to check the entire manufacturing cycle; to adopt possible improvements immediately; better sensitivity to market request adjusting product range design in real time.



### STANDARD EQUIPMENT



### PROFESSIONAL COLD WATER HIGH-PRESSURE CLEANERS

code	8.673.0001C
operating pressure bar	140 (max 180)
max delivery rate l/h	540
abs. power W/Voltage	2800 - 230V~50Hz
RPM	2800
weight	23 Kg
packing dim.	39 x 39 h 71 cm
pcs for pallet	12

Q.ty: 20'=108 40'=228 40' HC=304  
Floor loaded not available.

## Maine 1409 XP

**NEW**

- Three steel pistons, brass axial pump head with built-in by-pass valve.
- Suction and delivery S. S. valves.
- Integrated detergent suction with external suction probe.
- Power cable holder.
- High pressure hose holder (8m).
- Accessory holder.
- Ergonomic handle.



95  
39  
Cm  
34

**T.S.** Total Stop

## Bolt 1510 LP

- 4 poles electrical motor (1450 RPM) with thermal protection
- Three ceramic coated pistons, brass linear pump head with built-in by-pass valve
  - Suction and delivery S/S valves
    - Total stop
    - Safety valve for overpressure
  - Integrated detergent suction with external suction probe
    - Power cable (5 m)
    - Pressure regulator
    - Glycerine pressure gauge

### PROFESSIONAL COLD WATER HIGH-PRESSURE CLEANERS

code	8.668.0027C
operating pressure bar	30÷150
max delivery rate l/h	540
abs. power W/Voltage	2800 - 230V~50Hz
RPM	1450
weight	36 Kg
packing dim.	47 x 57,5 h 57 cm
pcs for pallet	12

Q.ty: 20'=108 40'=228 40' HC=304  
Floor loaded not available.

### STANDARD EQUIPMENT (Only for 1510 model)



Available also: Bolt 1211 LP (8.668.0005C): 230V-50Hz - 120 bar (max 150) - 660 l/h - 2800W - 1450 RPM  
Bolt 1509 LP (8.668.0006C): 230V-50Hz - 150 bar - 540 l/h - 2800W - 1450 RPM





**T.V.** Thermal Valve

## Aral-R 1211 LP

- 4 poles electrical motor (1450 RPM) with thermal protection
- Three ceramic coated pistons, brass linear pump head with built-in by-pass valve
- Suction and delivery S/S valves
- Safety valve for overpressure
- Integrated detergent suction with external suction probe
- Power cable (5 m)
- Pressure regulator
- Glycerine pressure gauge

87  
85  
Cm  
52

### PROFESSIONAL COLD WATER HIGH-PRESSURE CLEANERS

code	8.660.0601C
operating pressure bar	30±125
max delivery rate l/h	660
abs. power W/Voltage	3000 - 230V~50Hz
RPM	1450
weight	45 Kg
packing dim.	56 x 67 h 61 cm
pcs for pallet	6

Q.ty: 20'=66 40'=192 40' HC=192  
Floor loaded not available.

### STANDARD EQUIPMENT



Available also 60Hz versions:  
Aral-R 1211 on request: 220V-60Hz 1 ph. - 435±1740 psi - 2.91 GPM - 3000W - 1700 RPM  
Aral-R 2013 on request: 220V-60Hz 3 ph. - 435±1740 psi - 3.44 GPM - 6800W - 1700 RPM

### STANDARD EQUIPMENT



Available also Aral-R 1515 (8.660.0602C): 400V-50Hz - 150 bar - 900 l/h - 5000W - 1450 RPM  
Available also Aral-R 2517 (8.660.0624C): 400V-50Hz - 250 bar - 1020 l/h - 9400W - 1450 RPM

## Aral-R 2015 LP

**T.V.** Thermal Valve

### PROFESSIONAL COLD WATER HIGH-PRESSURE CLEANERS

code	8.660.0603C
operating pressure bar	30±200
max delivery rate l/h	900
abs. power W/Voltage	7000 - 400V~50Hz
RPM	1450
weight	60 Kg
packing dim.	56 x 67 h 61 cm
pcs for pallet	6

Q.ty: 20'=66 40'=192 40' HC=192  
Floor loaded not available.

- 4 poles electrical motor (1450 RPM) with thermal protection
- Three ceramic coated pistons, brass linear pump head with built-in by-pass valve
- Suction and delivery S/S valves
- Safety valve for overpressure
- Integrated detergent suction with external suction probe
- Power cable (5 m)
- Pressure regulator
- Glycerine pressure gauge

87  
85  
Cm  
52



Available also 60Hz versions:  
Aral-R 2013 on request: 400V-60Hz 3 ph. - 435±1740 psi - 3.44 GPM - 6800W - 1700 RPM

**T.V.** Thermal Valve

## Thermic 6,5

- Unleaded gasoline engine
- Three S/S pistons, brass linear pump head with built-in by-pass valve
- By-pass thermal protection with safety valve
- Integrated detergent suction with external suction probe
- Pressure regulator
- Glycerine pressure gauge
- Accessory holder
- Hose-holder
- Ergonomic handle

97  
47  
Cm  
47

### PROFESSIONAL COLD WATER HIGH-PRESSURE CLEANERS WITH COMBUSTION ENGINE

code	8.601.0175C
operating pressure bar	30±180 (max 210)
max delivery rate l/h	690
motor power hp	6,5
RPM	3600
weight (Kg)	38,5
packing dim. (cm)	47 x 57 h 57
pcs for pallet	16

Q.ty: 20'=108 40'=240 40' HC=384  
Floor loaded not available.

### STANDARD EQUIPMENT





### Thermic 9L

- Unleaded gasoline engine
- Three ceramic pistons, brass linear pump head with built-in by-pass valve
- By-pass thermal protection with safety valve
- Integrated detergent suction with external suction probe
- Pressure regulator
- Glycerine pressure gauge
- Accessory holder
- Hose-holder
- Ergonomic handle

PROFESSIONAL COLD WATER HIGH-PRESSURE CLEANERS WITH COMBUSTION ENGINE

code	8.601.0188C
operating pressure bar	220 (max 250)
max delivery rate l/h	900
motor power hp	9
RPM	3400
weight	56 Kg
packing dim.	50 x 59 h 60 cm
pcs for pallet	12

Q.ty: 20'=108 40'=240 40' HC=240  
Floor loaded not available.

#### STANDARD EQUIPMENT



#### STANDARD EQUIPMENT



PROFESSIONAL HOT WATER HIGH-PRESSURE CLEANERS

code	8.627.0001C
operating pressure bar	30±110
max delivery rate l/h	660
abs. power W/Voltage	3000 - 230V~50Hz
RPM	1450
weight	140 Kg
packing dim.	130 x 77 h 111 cm
pcs for pallet	1

Q.ty: 20'=24 40'=54 40' HC=54  
Floor loaded not available.

### Torrens 1211 LP

- 4 poles electrical motor (1450 RPM) with thermal protection with built-in by-pass valve
- Suction and delivery S/S valve
- Total stop
- Power cable (m 5)
- Auxiliary motor for burner air-cooling and two ways fuel pump
- Temperature regulation gauge
- Glycerine pressure gauge
- Vertical burner with high thermal efficiency steel coil



Available also 60Hz versions:  
Torrens 1211 (8.627.0005C): 220V-60Hz 1 ph. - 435=1595 psi - 2.91 GPM - 3200W - 1700 RPM  
Torrens 2013 (8.627.0004C): 220V-60Hz 3 ph. - 435=1740 psi - 3.44 GPM - 7000W - 1700 RPM



### Torrens 2015 LP

- 4 poles electrical motor (1450 RPM) with thermal protection
- with built-in by-pass valve
- Suction and delivery S/S valve
- Total stop
- Power cable (m 5)
- Auxiliary motor for burner air-cooling and two ways fuel pump
- Temperature regulation gauge
- Glycerine pressure gauge
- Vertical burner with high thermal efficiency steel coil

PROFESSIONAL HOT WATER HIGH-PRESSURE CLEANERS

code	8.627.0003C
operating pressure bar	30±200 (max 210)
max delivery rate l/h	900
abs. power W/Voltage	7300 - 400V~50Hz
RPM	1450
weight	144,5 Kg
packing dim.	130 x 77 h 111 cm
pcs for pallet	1

Q.ty: 20'=24 40'=54 40' HC=54  
Floor loaded not available.

#### STANDARD EQUIPMENT



Available also Torrens 1515 (8.627.0002C): 400V-50Hz - 150 bar - 900 l/h - 5500W - 1450 RPM  
Available also 60Hz versions:  
Torrens 2013 (8.627.0006C): 400V-60Hz 3 ph. - 435=1740 psi - 3.44 GPM - 7000W - 1700 RPM



## Wet & Dry professional vacuum cleaners



The Professional range of LAVOR PRO vacuum cleaners provides the solution for every kind of heavy duty daily use. Designed to be user friendly, they are equipped with ergonomic handle, big wheels and stable trolley offering the final answer to the needs of cleaning contactors, industries, workshops, car washing station etc. This feature avoids shocks to the end user, making usage easier. The filter area is reachable easily and the wide float seat grants stability on the floor during filter cleaning session.

### STANDARD EQUIPMENT



### PROFESSIONAL WET & DRY VACUUM CLEANERS

code	8.260.0002C
barcode	8013298067251
Power W	2000 (max 2400)
Column depress. mbar/kPa	200/20
Tank capacity l.	60
Suction air l/s	90
weight (Kg)	25,6
packing dim. (cm)	64 x 70 h 85
pcs for pallet	N.A

Load Q.ty: 20'=72 40'=147 40' HC=162

**PROFESSIONAL Ø40**

### Dozer 260 IR

**NEW**

- 2 silenced two stage motor.
- Suction system with by-pass cooling.
- S/S tank.
- Professional closing hooks.
- Static electric shock inhibitor.
- Flex hose 4 m
- Metal extension pipe
- Shock proof trolley.
- Liquid float valve.
- Cloth filter.
- 5 m power cable.
- Tilting tank



**NEW**

### Dozer 360 IR

### PROFESSIONAL WET & DRY VACUUM CLEANERS

code	8.261.0002C
barcode	8013298067237
Power W	3000 (max 3600)
Column depress. mbar/kPa	200/20
Tank capacity l.	60
Suction air l/s	106
weight (Kg)	27
packing dim. (cm)	64 x 70 h 85
pcs for pallet	N.A

Load Q.ty: 20'=72 40'=147 40' HC=162

**PROFESSIONAL Ø40**

### STANDARD EQUIPMENT



**NEW**

### Dozer 280 IR



- 2 silenced two stage motor.
- Suction system with by-pass cooling.
- S/S tank.
- Professional closing hooks.
- Static electric shock inhibitor.
- Flex hose 4 m
- Metal extension pipe
- Shock proof trolley.
- Liquid float valve.
- Cloth filter.
- 5 m power cable.
- Tilting tank



#### PROFESSIONAL WET & DRY VACUUM CLEANERS

code	8.260.0001C
barcode	8013298067244
Power W	2000 (max 2400)
Column depress. mbar/kPa	200/20
Tank capacity l.	80
Suction air l/s	90
weight (Kg)	25,6
packing dim. (cm)	64 x 70 h 100
pcs for pallet	N.A

Load Q.ty: 20'=54 40'=108 40' HC=141

#### STANDARD EQUIPMENT



**PROFESSIONAL Ø40**

#### STANDARD EQUIPMENT



#### PROFESSIONAL WET & DRY VACUUM CLEANERS

code	8.261.0001C
barcode	8013298067220
Power W	3000 (max 3600)
Column depress. mbar/kPa	200/20
Tank capacity l.	80
Suction air l/s	106
weight (Kg)	27
packing dim. (cm)	64 x 70 h 100
pcs for pallet	N.A

Load Q.ty: 20'=54 40'=108 40' HC=141

### Dozer 380 IR

**NEW**

- 3 silenced two stage motor.
- Suction system with by-pass cooling.
- S/S tank.
- Professional closing hooks.
- Static electric shock inhibitor.
- Flex hose 4 m
- Metal extension pipe
- Shock proof trolley.
- Liquid float valve.
- Cloth filter.
- 5 m power cable.
- Tilting tank

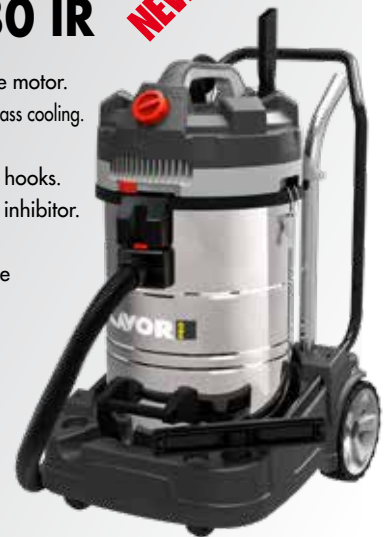

**PROFESSIONAL Ø40**





## High pressure pump



Lavor PRO offers a comprehensive range of pumps and motor pumps constructed and designed to meet any requirement of the market, and the needs of the most demanding customers, seeking for top quality and durability for this kind of products.

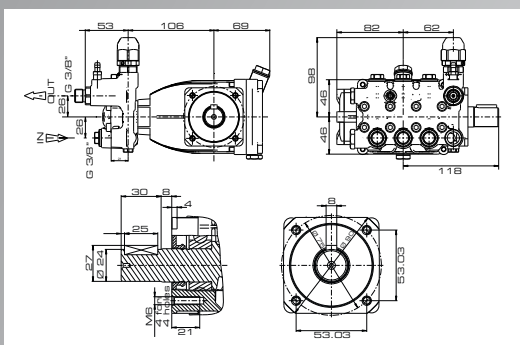

### CL4 Pump



- Three ceramic coated pistons, brass linear pump head with built-in by-pass valve
- Suction and delivery S/S valves
- Integrated detergent suction with external suction probe
- Pressure regulator



Model	Right shaft ver.		Left shaft ver.		RPM	Max. pressure bar	Flow rate l/m		Requested power HP kW		Weight kg	
	Code	Code										
CL 44-15 9-200	5.702.0018	5.702.0019	1450	1750	200	9	11	4,9	6	3,6	4,4	6,6
CL 44-15 11-200	5.702.0020	5.702.0021	1450	1750	200	11	13	6	6,5	4,4	4,8	6,6
CL 44-18 15-200	5.703.0006	5.703.0007	1450	1750	200	15	18	7,5	9,2	5,5	6,9	7

## Iron 2015 LP

PROFESSIONAL COLD WATER  
HIGH - PRESSURE CLEANERS

STANDARD EQUIPMENT



- 4 poles electrical motor (1450 RPM) with thermal protection
- Three ceramic coated pistons, brass linear pump head with built-in by-pass valve
- Suction and delivery S/S valves
- By-pass thermal protection with safety valve
- Integrated detergent suction with external suction probe
- Power cable (5 m)
- Pressure regulator
- Glycerine pressure gauge

code	8.670.0001C
operating pressure bar	30=200 (max 210)
max delivery rate l/h	900
abs. power W/Voltage	7000 - 400V~50Hz
RPM	1450
weight	- Kg
packing dim.	79,5 x 49 h 40 cm
pcs for pallet	-

Q.ty: 20'=66 40'=144 40' HC=144  
Floor loaded not available.



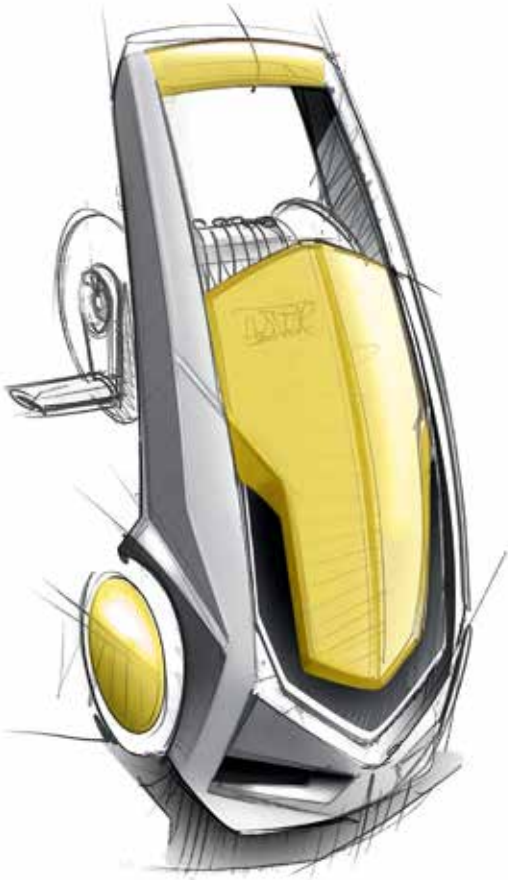

# PRIVATE LABELS

A wide range of electric and petrol domestic and professional pressure washers, vacuum cleaners, offering every customer the most suitable appliance for his market.

With more than forty years of manufacturing experience, Lavorwash gives its customers the possibility of ordering "**taiilor made**" products to meet all their requirements.

Modern Italian Technology, Design, Quality, Flexibility and Fast Reaction are features that have always been the Milestone of our Group.

**GENERAL TERMS OF SALE** Goods travel at buyer's risk. Images and technical specifications of products and accessories are not binding and can be modified without notice.



Lavorwash is Official  
Sponsor of Pallacanestro  
Reggiana Italian A Series  
Basketball league.

**amfori** @ BSCI  
Trade with purpose



Management system certified  
**ISO 9001**

Follow us on  
**You Tube** **f** **in**

# LAVOR

Manufacturing:

**Yong Kang LavorWash Equipment Co.,Ltd**

Add: No.80 Huacheng West Road.

Yongkang City, Zhejiang - China (zip code 321300)

Tel: 0086 057987102020 Mob: 0086 13738919487 Fax: 0086 057987102022

E-mail: sales.lavorchina@vip.163.com - Web site: www.lavorchina.cn

Sales:

**LAVORWASH S.p.A.** J.F.Kennedy, 12 - 46020 Pegognaga (MN) Italy

Tel. 0039 0376 55431 - Fax 0039 0376 558927

E-mail: info@lavorwash.it - WebSite: www.lavor.it

