

*Accessori - Ricambi
Pompe - Caldaie*

LAVORWASH

SERVICE



*Accessories - Spare Parts
Pumps - Boilers*

**Lavorwash è**

uno dei maggiori produttori al mondo di Sistemi di Pulizia ad alta tecnologia per piccole e grandi superfici, sia interne che esterne. Lavorwash nasce nel 1975; la sua attività si è progressivamente sviluppata e l'attuale struttura conta più di 300 addetti ed oltre 300 collaboratori. Prodotti conformi alle normative europee e omologati dai più severi laboratori del mondo.

Lavorwash rispetta la natura. I suoi Sistemi di Pulizia permettono un elevato recupero di acqua, fino all'80% rispetto ai metodi di pulizia tradizionali; consentono un notevole risparmio energetico; sono conformi alle normative europee in termini di silenziosità.

Lavorwash is

One of the world-leaders in manufacturing hi-tech cleaning systems, suitable for small and large surfaces, both indoor and outdoor. The company was set up in 1975: its activity has progressively expanded and now Lavorwash is employing over 300 people as well as 300 associates. Products complying with European standards and approved by the strictest test labs all over the world.

Lavorwash respects nature. Its cleaning systems allow a remarkable water recovery - up to 80% if compared with traditional ones - and a significant energy saving, while complying with European standards as far as noise level is concerned.

www.lavorservice.com



LAVORWASH SERVICE, LAVOR e LAVOR PRO sono online

e dispongono di siti ricchi di informazioni sull'azienda, sui prodotti e sui servizi offerti facilmente consultabili grazie ad una navigazione organizzata tramite passaggi semplici e diretti, con dati continuamente aggiornati.

www.lavorservice.com - www.lavorwash.it - www.lavorpro.com
basta un click per collegarsi al mondo LAVORWASH SERVICE, LAVOR e LAVOR PRO: informazioni, prodotti e novità sono a disposizione di tutti gli utenti.

LAVORWASH SERVICE, LAVOR and LAVOR PRO are on line

offering websites rich with informations about the company, products and services offered. The sites are easy to explore thanks to a navigation system organised around simple and straightforward steps, with continually updated data.

www.lavorservice.com - www.lavorwash.it - www.lavorpro.com

connecting to the LAVORWASH SERVICE, LAVOR and LAVOR PRO world is just a click away: information, products and news at the fingertips of every user.

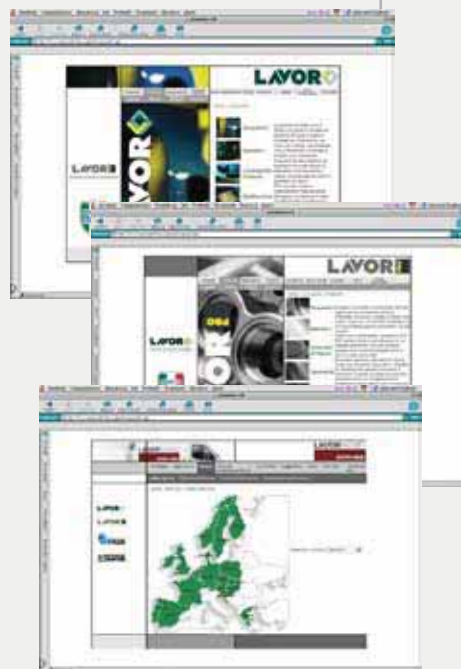

Idropultrici
High pressure cleaners

pag. 6



Aspiratori
Vacuum cleaners

pag. 114



Monospazzole
Single disc machines

pag. 132



Lavasciugapavimenti
Floor scrubber driers

pag. 138



Spazzatrici
Sweepers

pag. 156



Generatori di vapore
Steam generators

pag. 168



Nebulizzatori
Sprayers

pag. 170



Macchine per taglio legno
Wood cutting machines

pag. 178



Prodotti chimici
Chemical products

pag. 180



WAVE

IDROPULTRICI

HIGH PRESSURE CLEANERS

SEERVO

IDROPULTRICI HIGH PRESSURE CLEANERS

ACCESSORI

- Pistole e adattatori
- Tubi e sonde spurgatubi
- Lance e lance turbo
- Ugelli ad alta pressione
- Ugelli rotanti
- Manometri
- Filtri
- Spazzole e patio cleaners
- Avvolgitubo
- Lancia schiuma
- Regolatori di portata
- Accessori generici

RICAMBI

- Pompe complete
- Accessori per pompe
- Parti di ricambio per pompe
 - Tenute acqua
 - Tenute olio
 - Valvole di aspirazione e mandata
 - Pistoni e bielle
 - Valvole di sicurezza e termiche
 - Anelli O-Ring
 - Valvole di By-pass
 - Raccordi, innesti e riduzioni

CALDAIE

- Caldaie complete
- Parti di ricambio per caldaie
 - Serpentine e refrattari
 - Pompe gasolio
 - Ugelli gasolio
 - Filtri gasolio
 - Motori di ventilazione
 - Strumentazione di controllo
 - Trasformatori di accensione
 - Elettrodi e cavi

PARTI ELETTRICHE

- Motori a scoppio
- Motori elettrici
- Pressostati e flussostati
- Teleruttori, relè e disgiuntori termici
- Interruttori
- Condensatori
- Schede di controllo e TSS

ACCESSORIES

- Guns and adapters 8
- Hoses and pipe cleaning hoses 17
- Lances and rotox lances 24
- High pressure nozzles 35
- Rotating heads 38
- Manometers 40
- Filters 40
- Brushes and patio cleaners 41
- Hose reels 43
- Foam injector lances 43
- Water flow adjusters 45
- Generic accessories 45

SPARE PARTS

- Complete high pressure pumps 51
- Accessories for pumps 77
- Spare parts for pumps 79
 - Water seals 79
 - Oil seals 81
 - Valves 82
 - Pistons and connecting rods 83
 - Pressure and thermal relief valves 83
 - O-Rings 85
 - By-pass valves 88
 - Coupling, nipples and reductions 91

BOILERS

- Complete boilers 95
- Spare parts for boilers 100
 - Coils and refractory stones 100
 - Fuel pumps 102
 - Fuel nozzles 103
 - Fuel filters 103
 - Burner ventilation motors 104
 - Controls 104
 - Ignition transformers 105
 - Cables and electrodes 105

ELECTRIC COMPONENTS

- Combustion engines 106
- Electric motors 107
- Pressure and flow switches 109
- Contactors, relays and thermal breakers 109
- Switches 111
- Capacitors 111
- Control systems and TSS 112

Accessori per idropultrici Accessories for high pressure cleaners

Pistole per idropultrici hobby Guns for domestic high pressure cleaners



Codice Code	Descrizione Description	Pressione Pressure			Portata Flow rate		Lunghezza Length mm	Entrata Inlet A	Uscita Outlet B	Tipo Type
		bar	psi	MPa	l/m	GPM				
6.001.0076	Pistola S'09 con attacco rapido Gun S'09 with quick coupling	160	2300	16	15	3.97	450	Rapido Quick Lavor	Baionetta Bayonet Lavor	Plastica Plastic
6.001.0083	Pistola S'09 completa di attacco rapido 5.009.0751 Gun S'09 complete with quick coupling 5.009.0751	160	2300	16	15	3.97	450	Rapido Quick Lavor	Baionetta Bayonet Lavor	Plastica Plastic
6.001.0079	Pistola SY'09 con attacco rapido Gun SY'09 with quick coupling	160	2300	16	15	3.97	450	Rapido Quick Lavor	Baionetta Bayonet Lavor	Ottone Brass

Adattatori per tubi ad alta pressione/pistole
Adapters for high pressure hoses/ guns

Pistole Lavor con attacco rapido/ tubi di altri marchi
Quick coupling Lavor guns / hoses of other brands

Codice - Code : 5.009.0751



Pistola Lavor
Lavor gun

Attacco rapido Lavor
Lavor quick coupling



5.009.0751

1/4" M

1/4" F

Tubo
Hose

Tutti i marchi
All brands



Codice - Code : 6.005.0343



Pistola Lavor
Lavor gun

Attacco rapido Lavor
Lavor quick coupling



6.005.0343

Tubo
Hose

Innesto rapido Karcher
Quick coupling Karcher



Codice - Code : 6.005.0342 - 3 adattatori/adapters



Pistola Lavor
Lavor gun

Attacco rapido Lavor
Lavor quick coupling



6.005.0342

Tubo
Hose

Innesti rapidi Annovi e B&D
Quick couplings Annovi and B&D



Codice - Code : 6.005.0358



Pistola Lavor
Lavor gun

Attacco rapido Lavor
Lavor quick coupling



6.005.0358

Tubo
Hose

Attacco rapido Karcher
- nuovo tipo -
Quick coupling Karcher
- new type -



Pistole con attacco 1/4" M / tubi Lavor e altri marchi
Guns with coupling 1/4" M / Lavor and other brands hoses

Codice - Code : 6.005.0349



Pistola Lavor
Lavor gun
1/4" M



6.005.0349



Tubo
Hose
Innesto rapido Lavor
Lavor quick coupling

Codice - Code : 6.005.0345



Pistola Lavor
Lavor gun
1/4" M



1/4" F
6.005.0345



Innesto rapido Karcher
Quick coupling Karcher

Tubo
Hose

Codice - Code : 6.005.0344 - 3 adattatori/adapters



Pistola Lavor
Lavor gun
1/4" M



6.005.0344



Tubo
Hose

Innesti rapidi: Annovi e B&D
Quick couplings Annovi and B&D

Codice - Code : 6.005.0357



Pistola Lavor
Lavor gun
1/4" M

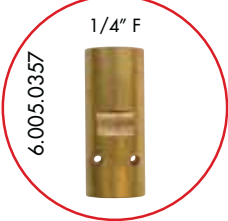

1/4" F
6.005.0357



Attacco rapido Karcher
- nuovo tipo -
Quick coupling Karcher
- new type -

Tubo
Hose

Pistole altri marchi / tubi con attacco 1/4" F e M22 F
Guns of other brands / hoses with 1/4" F and M22 F coupling

Codice - Code : 6.005.0329



Attacco rapido Annovi e B&D
Quick coupling Annovi and B&D

6.005.0329



1/4" M

1/4" F

Tubo
Hose

Tutti i marchi
All brands



Codice - Code : 6.005.0328



Attacco rapido Karcher
Quick coupling Karcher

6.005.0328



1/4" M

1/4" F

Tubo
Hose

Tutti i marchi
All brands



Codice - Code : 5.009.0811



Attacco rapido Karcher
- nuovo tipo -
Quick coupling Karcher
- new type -

5.009.0811



1/4" M

1/4" F

Tubo
Hose

Tutti i marchi
All brands



Codice - Code : 5.009.0812



Attacco rapido Karcher
- nuovo tipo -
Quick coupling Karcher
- new type -

5.009.0812



M22 Ø15

M22 F Ø15



Tubo
Hose



Tutti i marchi
All brands





Adattatori per lance ad alta pressione (B)



Adapters for high pressure lances (B)



<p>Adatto per pistole ad alta pressione LAVOR</p> <p>Suitable for high pressure guns LAVOR</p>	 <p>B</p>	<p>Da - From</p> <p>B: Attacco a baionetta piccolo LAVOR - vecchio tipo</p> <p>B: Small bayonet coupling LAVOR - old type</p>	<p>Codice - Code : 6.003.0042</p>  <p>B A</p>	<p>A - To</p> <p>A : Attacco a baionetta LAVOR - nuovo tipo</p> <p>A: Bayonet coupling LAVOR - new type</p>
--	---	--	---	--

<p>Adatto per pistole ad alta pressione LAVOR</p> <p>Suitable for high pressure guns LAVOR</p>	 <p>B</p>	<p>Da - From</p> <p>B: Attacco a baionetta LAVOR - nuovo tipo</p> <p>B: Bayonet coupling LAVOR - new type</p>	<p>Codice - Code : 6.003.0078</p>  <p>B A</p>	<p>A - To</p> <p>A : Attacco a baionetta B&D - Annovi - nuovo tipo</p> <p>A: Bayonet coupling B&D - Annovi - new type</p>
--	---	--	---	--



<p>Adatto per pistole ad alta pressione LAVOR</p> <p>Suitable for high pressure guns LAVOR</p>	 <p>B</p>	<p>Da - From</p> <p>B: Attacco a baionetta LAVOR - nuovo tipo</p> <p>B: Bayonet coupling LAVOR - new type</p>	<p>Codice - Code : 6.003.0041</p>  <p>B A</p>	<p>A - To</p> <p>A : Attacco a baionetta piccolo LAVOR - B&D - Annovi - vecchio tipo</p> <p>A: Small bayonet coupling LAVOR - B&D - Annovi - old type</p>
--	---	--	---	--

<p>Adatto per pistole ad alta pressione KARCHER</p> <p>Suitable for high pressure guns KARCHER</p>	 <p>B</p>	<p>Da - From</p> <p>B: Attacco a baionetta Karcher</p> <p>B: Bayonet coupling Karcher</p>	<p>Codice - Code : 6.003.0059</p>  <p>B A</p>	<p>A - To</p> <p>A: Attacco a baionetta piccolo LAVOR - B&D - Annovi - vecchio tipo</p> <p>A: Small bayonet coupling LAVOR - B&D - Annovi - old type</p>
--	---	--	---	---

<p>Adatto per pistole ad alta pressione KARCHER</p> <p>Suitable for high pressure guns KARCHER</p>	 <p>B</p>	<p>Da - From</p> <p>B: Attacco a baionetta Karcher</p> <p>B: Bayonet coupling Karcher</p>	<p>Codice - Code : 6.003.0047</p>  <p>B A</p>	<p>A - To</p> <p>A: Attacco a baionetta LAVOR - nuovo tipo</p> <p>A: Bayonet coupling LAVOR - new type</p>
--	---	--	---	---

Adattatori per lance ad alta pressione (B) Adapters for high pressure lances (B)

Adatto per pistole
ANNOVI REVERBERI
BLACK&DECKER

Suitable for guns
ANNOVI REVERBERI
BLACK&DECKER



Da - From

B: Attacco a baionetta
B&D - Annovi - nuovo
tipo

B: Bayonet coupling B&D
- Annovi - new type

Codice - Code : 6.003.0077

A - To

A : Attacco a baionetta
Lavor - nuovo tipo

A: Bayonet coupling Lavor -
new type



NEW

Adatto per pistole
ANNOVI REVERBERI
BLACK&DECKER

Suitable for guns
ANNOVI REVERBERI
BLACK&DECKER



Da - From

B: Attacco a baionetta
piccolo B&D - Annovi -
vecchio tipo

B: Small bayonet
coupling B&D - Annovi -
old type

Codice - Code : 6.003.0042

A - To

A : Attacco a baionetta
Lavor - nuovo tipo

A: Bayonet coupling Lavor -
new type



Adatto per pistole
FAIP

Suitable for guns
FAIP



Da - From

B: Attacco a baionetta
Faip

B: Bayonet coupling
Faip

Codice - Code : 6.003.0030

A - To

A : Attacco a baionetta
Lavor - vecchio tipo

A: Bayonet coupling Lavor -
old type



Adatto per pistole
FAIP

Suitable for guns
FAIP



Da - From

B: Attacco a baionetta
Faip

B: Bayonet coupling
Faip

Codice - Code : 6.003.0079

A - To

A : Attacco a baionetta
Lavor - nuovo tipo

A: Bayonet coupling Lavor -
new type



Pistole per idropulitrici semiprofessionali e professionali

Guns for professional high pressure cleaners

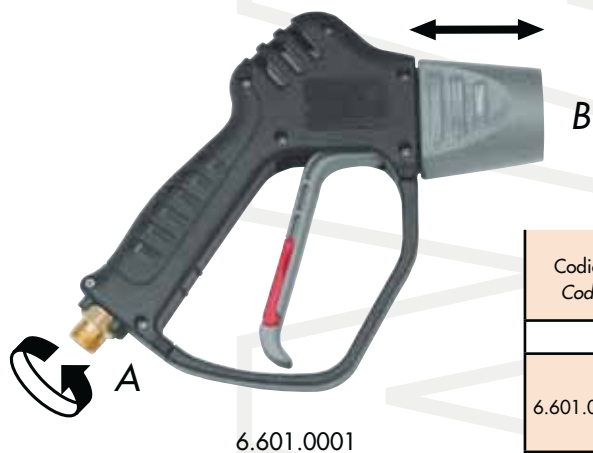

6.601.0001

Raccordo 3/8" F - M22Ø14
Coupling 3/8" F - M22Ø14



Codice - Code :
3.479.0463

Codice Code	Descrizione Description	Pressione Pressure			Portata Flow rate		Lunghezza Length mm	Entrata Inlet A	Uscita Outlet B
		bar	psi	MPa	l/m	GPM			
6.601.0001	Pistola PRO S10 Gun PRO S10	280	4060	28	25	6.61	200	Girevole Swivel 3/8" M	Rapido a sfere Quick ball coupling

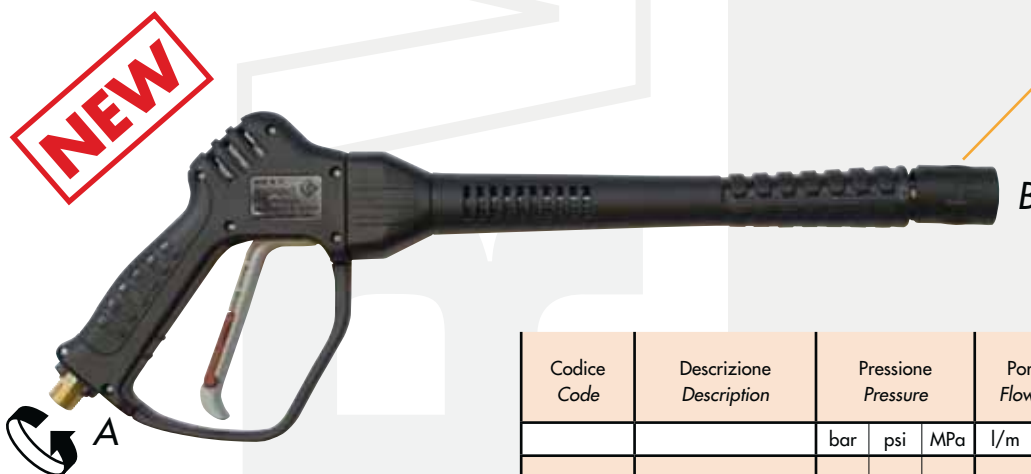

6.601.0002

Raccordo di ricambio 1/4" F - M22Ø14
Spare coupling 1/4" F - M22Ø14
Codice/Code: 3.099.1472

Kit di ricambio: 10 O-Ring + 10 parbak
Spare kit: 10 O-Ring + 10 parbak
Codice/Code: 6.005.0229

Codice Code	Descrizione Description	Pressione Pressure			Portata Flow rate		Lunghezza Length mm	Entrata Inlet A	Uscita Outlet B
		bar	psi	MPa	l/m	GPM			
6.601.0002	Pistola PRO S10 Gun PRO S10	280	4060	28	25	6.61	450	Girevole Swivel 3/8" M	M22 Ø14



6.001.0089

Raccordo di ricambio 1/4" F - M22Ø14
Spare coupling 1/4" F - M22Ø14
Codice/Code: 3.099.1472

Kit di ricambio: 10 O-Ring + 10 parbak
Spare kit: 10 O-Ring + 10 parbak
Codice/Code: 6.005.0229

Codice Code	Descrizione Description	Pressione Pressure			Portata Flow rate		Lunghezza Length mm	Entrata Inlet A	Uscita Outlet B
		bar	psi	MPa	l/m	GPM			
6.001.0089	Pistola S10Y Gun S10Y	225	3263	25	20	5.29	450	Rapido Quick Lavor	M22 Ø14



A
3.700.0025

Codice Code	Descrizione Description	Pressione Pressure			Portata Flow rate		Lunghezza Length mm	Entrata Inlet A	Uscita Outlet B	Tipo Type
		bar	psi	MPa	l/m	GPM				
3.700.0022	Pistola 350 bar Gun 350 bar	350	5075	35	30	7.94	200	3/8" M	M24 Twist	Compensata Compensated
3.700.0025	Pistola 300 bar Gun 300 bar	300	4350	30	40	10.58	200	3/8" M	1/4" F	---

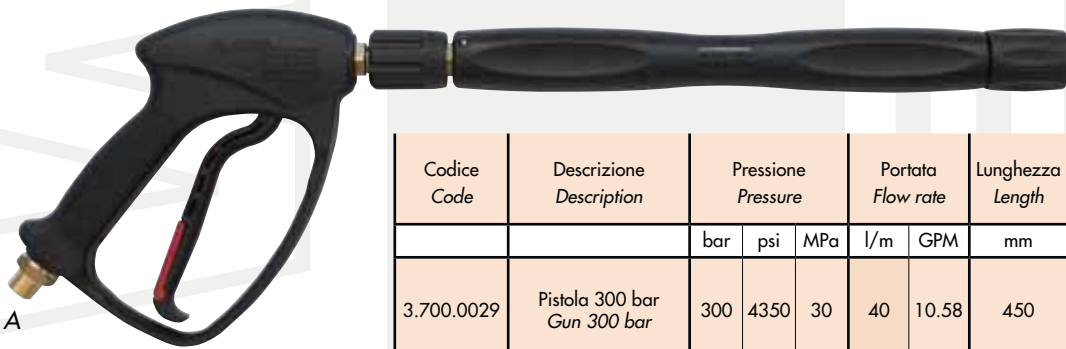

A
3.700.0029

Kit di ricambio: 10 O-Ring + 10 parbak
Spare kit: 10 O-Ring + 10 parbak
Codice/Code: 6.005.0229

Codice Code	Descrizione Description	Pressione Pressure			Portata Flow rate		Lunghezza Length mm	Entrata Inlet A	Uscita Outlet B	Tipo Type
		bar	psi	MPa	l/m	GPM				
3.700.0029	Pistola 300 bar Gun 300 bar	300	4350	30	40	10.58	450	3/8" M	M22 Ø14	Regolatore pressione Pressure regulator



A
3.700.0036

Kit di ricambio: 10 O-Ring + 10 parbak
Spare kit: 10 O-Ring + 10 parbak
Codice/Code: 6.005.0229

Codice Code	Descrizione Description	Pressione Pressure			Portata Flow rate		Lunghezza Length mm	Entrata Inlet A	Uscita Outlet B
		bar	psi	MPa	l/m	GPM			
3.700.0036	Pistola 290 bar Gun 290 bar	290			21		450	3/8" M	M22 Ø14
6.001.0071	Pistola 230 bar Gun 230 bar	230	3335	23	25	6.61	450	Inox St. Steel 3/8" M	M22 Ø14



6.001.0071



Kit di riparazione per pistola - ingresso 3/8"
Maintenance kit for guns - inlet 3/8"
Codice/Code: 6.605.0139





Raccordo di ricambio 1/4" F - M22 Ø14
Spare coupling 1/4" F - M22 Ø14
Codice/Code: 3.099.1472







Kit di ricambio: 10 O-Ring + 10 parbak
Spare kit: 10 O-Ring + 10 parbak
Codice/Code: 6.005.0229



Adattatori per lance ad alta pressione (B)

Adapters for high pressure lances (B)

<p>Adatto per pistole alta pressione con attacco M22 Suitable for high pressure guns with coupling M22</p>	 <p>B</p>	<p>Da - From</p> <p>B: Attacco M22 Ø14 B: Coupling M22 Ø14</p>	 <p>B A</p> <p>Codice - Code : 6.003.0045</p>	<p>A - To</p> <p>A: Attacco a baionetta Lavor - nuovo tipo A: Bayonet coupling Lavor - new type</p>
--	---	---	---	--

<p>Adatto per pistole alta pressione con attacco M24 Suitable for high pressure guns with coupling M24</p>	 <p>B</p>	<p>Da - From</p> <p>B: Attacco M24 Ø14 B: Coupling M24 Ø14</p>	 <p>B A</p> <p>Codice - Code : 3.749.0257</p> <p>Codice - Code : 3.749.0320</p>	<p>A - To</p> <p>A: Attacco 3/8" F A: Coupling 3/8" F</p> <p>A: Attacco 1/4" F A: Coupling 1/4" F</p>
--	---	---	---	--

<p>Adatto per pistole alta pressione con attacco rapido a sfere Suitable for high pressure guns with quick ball coupling</p>	 <p>B</p>	<p>Da - From</p> <p>B: Attacco rapido a sfere B: Quick ball coupling</p>	 <p>B A</p> <p>Codice - Code : 5.609.0251</p>	<p>A - To</p> <p>A: Attacco M22 Ø14 A: Coupling M22 Ø14</p>
--	---	---	---	--

<p>Adatto per pistole alta pressione con attacco rapido a sfere Suitable for high pressure guns with quick ball coupling</p>	 <p>B</p>	<p>Da - From</p> <p>B: Attacco rapido a sfere B: Quick ball coupling</p>	 <p>B A</p> <p>Codice - Code : 3.749.0474</p>	<p>A - To</p> <p>A: Attacco 1/4" F A: Coupling 1/4" F</p>
--	---	---	---	--

Kit innesto rapido tubo/pistola

Quick coupling kit hose - gun



Kit innesto rapido tubo/pistola - ottone - ingresso 3/8" - uscita 3/8" - 200 bar

Quick coupling kit hose/gun - brass - inlet 3/8" F - outlet 3/8" M - 200 bar
Codice/Code: 6.608.0003



Kit innesto rapido tubo/pistola - ottone - ingresso 1/4" - uscita 1/4" - 200 bar

Quick coupling kit hose/gun - brass - inlet 1/4" F - outlet 1/4" M - 200 bar
Codice/Code: 6.608.0002



Kit innesto rapido tubo/pistola - inox - ingresso 3/8" - uscita 3/8" - 250 bar

Quick coupling kit hose/gun - stainless steel - inlet 3/8" F - outlet 3/8" F - 250 bar
Codice/Code: 6.602.0021





Raccordo di giunzione per tubi M22 Ø15 - 1/4" M
 Connection coupling for hoses M22 Ø15 - 1/4" M
Codice/Code: 4.006.0062

Tubi termoplastici ad alta pressione per idropultrici hobby Thermoplastic high pressure hoses for domestic high pressure cleaners



Codice Code	Descrizione Description	Lunghezza Length	Pressione massima Max. pressure			Temperatura massima Maximum temperature	Ingresso Inlet	Uscita Outlet
			bar	psi	MPa			
		m						
4.018.0094	Tubo con manichette in plastica Hose with plastic hose bends Ø 1/4"	4	130	1885	13	60°	M22F/Ø15	Innesto rapido Quick coupling
4.018.0095	Tubo con manichette in plastica Hose with plastic hose bends Ø 1/4"	6	160	2320	16	60°	M22F/Ø15	Innesto rapido Quick coupling
4.018.0096	Tubo con manichette in plastica Hose with plastic hose bends Ø 1/4"	8	160	2320	16	60°	M22F/Ø15	Innesto rapido Quick coupling
4.018.0082	Tubo senza manichette Hose without hose bends Ø 1/4"	8	160	2320	16	60°	M22F/Ø15	Innesto rapido Quick coupling
4.018.0093	Tubo senza manichette Hose without hose bends Ø 1/4"	8	160	2320	16	60°	M22F/Ø15	Innesto rapido Quick coupling

Prolunga tubo per tubi hobby Lavor con innesto rapido Extension hose for domestic Lavor hoses with quick coupling

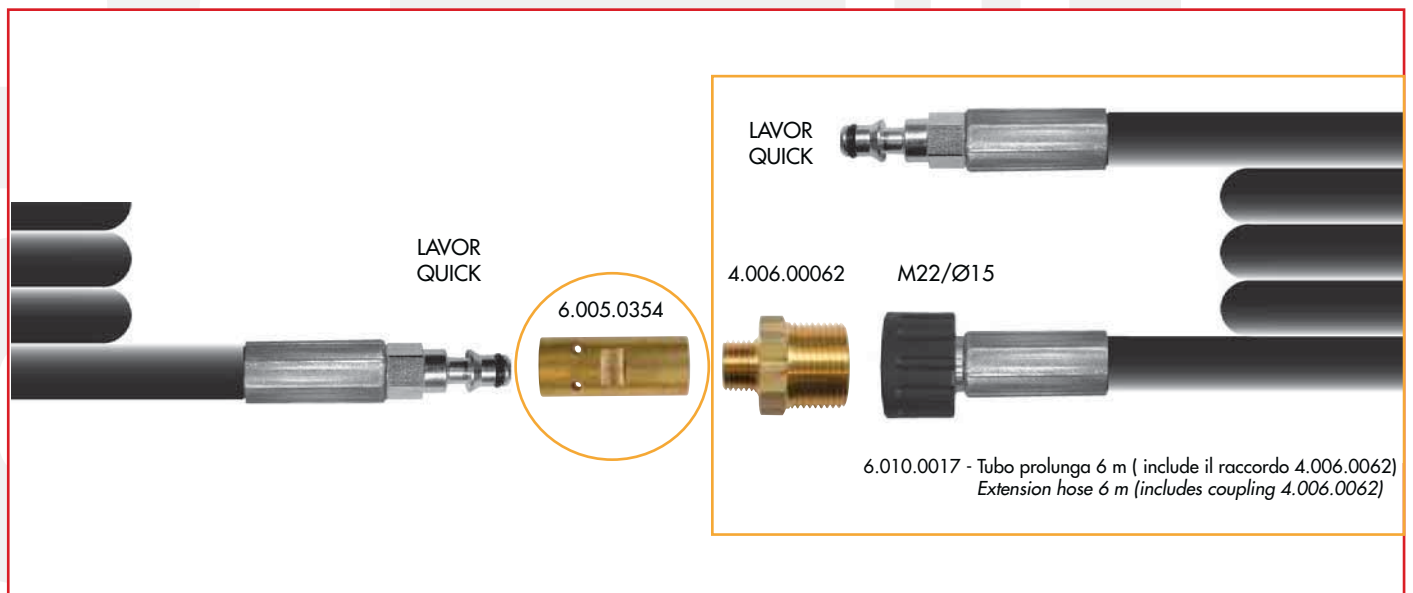

M22/Ø15 1/4" F



Codice Code	Descrizione Description	Lunghezza Length	Pressione massima Max. pressure			Temperatura massima Maximum temperature	Ingresso Inlet	Uscita Outlet	
			m	bar	psi				MPa
4.018.0076	Tubo senza manichette Hose without hose bends	Ø 1/4"	6	160	2320	16	60°	M22F/Ø15	1/4" F
4.018.0048	Tubo senza manichette Hose without hose bends	Ø 1/4"	8	140	2030	14	60°	M22F/Ø15	1/4" F
4.018.0061	Tubo senza manichette Hose without hose bends	Ø 1/4"	8	160	2320	16	60°	M22F/Ø15	1/4" F
4.018.0074	Tubo senza manichette Hose without hose bends	Ø 1/4"	10	160	2320	16	60°	M22F/Ø15	1/4" F
4.018.0085	Tubo senza manichette Hose without hose bends	Ø 1/4"	15	160	2320	16	60°	M22F/Ø15	1/4" F

Prolunga tubo per tubi hobby Lavor con innesto 1/4" F

Extension hose for domestic Lavor hoses with 1/4" F coupling

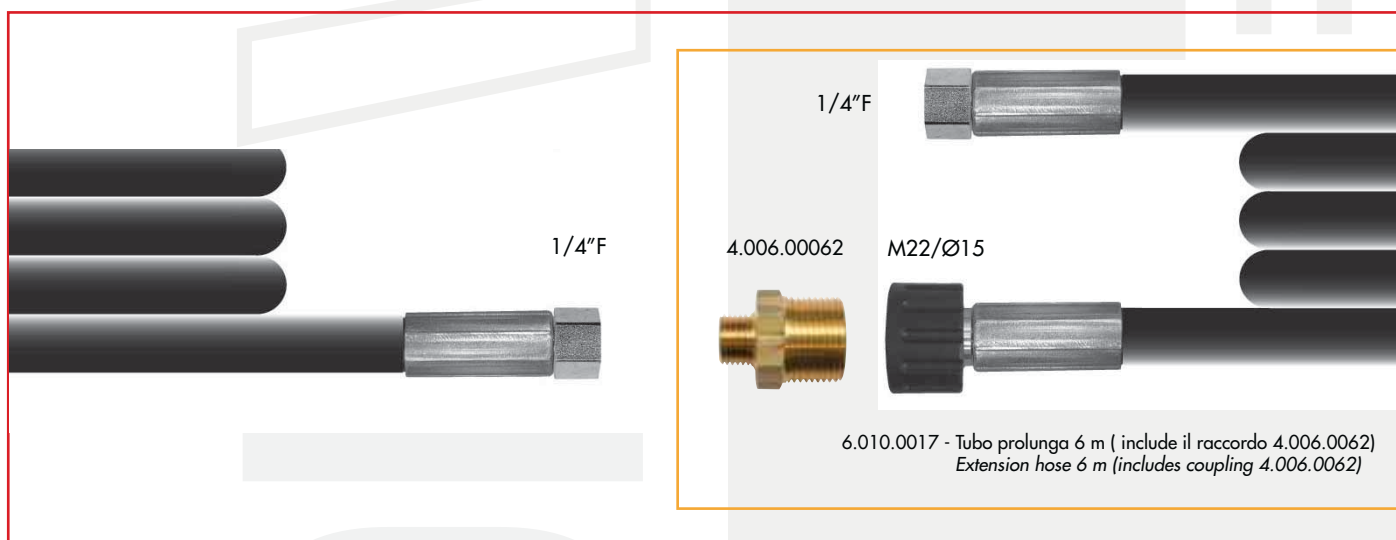

6.010.0017 - Tubo prolunga 6 m (include il raccordo 4.006.0062)
Extension hose 6 m (includes coupling 4.006.0062)

3/8" F 1/4" F



Codice Code	Descrizione Description	Lunghezza Length	Pressione massima Max. pressure			Temperatura massima Maximum temperature	Ingresso Inlet	Uscita Outlet	
			m	bar	psi				MPa
4.018.0052	Tubo senza manichette Hose without hose bends	Ø 1/4"	8	160	2320	16	60°	3/8" F	1/4" F
4.018.0067	Tubo senza manichette Hose without hose bends	Ø 1/4"	8	210	3045	21	150°	3/8" F	1/4" F
4.018.0042	Tubo senza manichette Hose without hose bends	Ø 1/4"	10	160	2320	16	60°	3/8" F	1/4" F

Per i raccordi di giunzione vedi pag. 19
For connection couplings see page 19



Tubi ad alta pressione per idropultrici professionali High pressure hoses for professional high pressure cleaners



Raccordo di giunzione per tubi M22 Ø15 - 1/4\"/>

Codice Code	Descrizione Description	Lunghezza Length	Pressione massima Max. pressure			Temperatura massima Maximum temperature	Ingresso Inlet	Uscita Outlet
			bar	psi	MPa			
		m	bar	psi	MPa			
4.618.0128	Tubo con manichette Hose with rubber hose bends Ø 1/4"	8	200	3045	21	60°	M22F/Ø15	1/4"F
4.018.0003	Tubo R1 con manichette Hose R1 with rubber hose bends Ø 1/4"	8	210	3045	21	150°	M22F/Ø15	1/4"F
4.618.0049	Tubo con manichette Hose with rubber hose bends Ø 1/4"	8	210	3045	21	100°	M22F/Ø15	3/8"F



Codice Code	Descrizione Description	Lunghezza Length	Pressione massima Max. pressure			Temperatura massima Maximum temperature	Ingresso Inlet	Uscita Outlet
			bar	psi	MPa			
		m	bar	psi	MPa			
4.618.0143	Tubo R2 con manichette Hose R2 with rubber hose bends Ø 5/16"	10	310	4496	31	150°	Innesto rapido Quick coupling 1/2"F	3/8"F
4.618.0153	Tubo R2 con manichette Hose R2 with rubber hose bends Ø 5/16"	20	310	4496	31	150°	Innesto rapido Quick coupling 1/2"F	3/8"F

Codice Code	Descrizione Description	Lunghezza Length	Pressione massima Max. pressure			Temperatura massima Maximum temperature	Ingresso Inlet	Uscita Outlet
			bar	psi	MPa			
		m	bar	psi	MPa			
4.618.0090	Tubo R1 con manichette Hose R1 with rubber hose bends Ø 1/4"	8	210	3045	21	150°	3/8"F	3/8"F
4.618.0053	Tubo R1 senza manichette Hose R1 without rubber hose bends Ø 1/4"	10	210	3045	21	100°	3/8"F	3/8"F
4.618.0152	Tubo R1 senza manichette Hose R1 without rubber hose bends Ø 1/4"	20	210	3045	21	150°	3/8"F	3/8"F
4.618.0150	Tubo R1 con manichette Hose R1 with rubber hose bends Ø 1/4"	50	210	3045	21	100°	3/8"F	3/8"F
4.618.0016	Tubo R1 con manichette Hose R1 with rubber hose bends Ø 5/16"	10	210	3045	21	150°	3/8"F	3/8"F
4.618.0017	Tubo R1 senza manichette Hose R1 without rubber hose bends Ø 5/16"	10	210	3045	21	150°	3/8"F	3/8"F
4.618.0012	Tubo R2 con manichette Hose R2 with rubber hose bends Ø 5/16"	10	315	4568	31.5	150°	3/8"F	3/8"F
4.618.0020	Tubo R2 con manichette Hose R2 with rubber hose bends Ø 5/16"	10	400	5801	40	150°	3/8"F	3/8"F
4.618.0129	Tubo R1 con manichette Hose R1 with rubber hose bends Ø 5/16"	20	210	3045	21	150°	3/8"F	3/8"F
4.618.0056	Tubo R2 con manichette Hose R2 with rubber hose bends Ø 5/16"	20	400	5801	40	150°	3/8"F	3/8"F
4.618.0050	Tubo R2 con manichette Hose R2 with rubber hose bends Ø 3/8"	10	400	5801	40	150°	3/8"F	3/8"F
4.618.0057	Tubo R2 con manichette Hose R2 with rubber hose bends Ø 3/8"	20	400	5801	40	150°	3/8"F	3/8"F





**Per l'industria alimentare
For food industry**



Codice Code	Descrizione Description	Lunghezza Length	Pressione massima Max. pressure			Temperatura massima Maximum temperature	Ingresso Inlet	Uscita Outlet
			bar	psi	MPa			
4.618.0058	Tubo alimentare R2 con manichette Ø 3/8"	10	400	5801	40	150°	3/8"F	3/8"F



Codice Code	Descrizione Description	Lunghezza Length	Pressione massima Max. pressure			Temperatura massima Maximum temperature	Ingresso Inlet	Uscita Outlet
			bar	psi	MPa			
4.618.0059	Tubo per vapore R2 con manichette Ø 3/8"	10	400	5801	40	135°	3/8"F	3/8"F

Adattatori e raccordi di giunzione per tubi hobby e professionali ad alta pressione/idropulitrice Adapters and couplings for domestic and professional high pressure hoses / high pressure cleaner

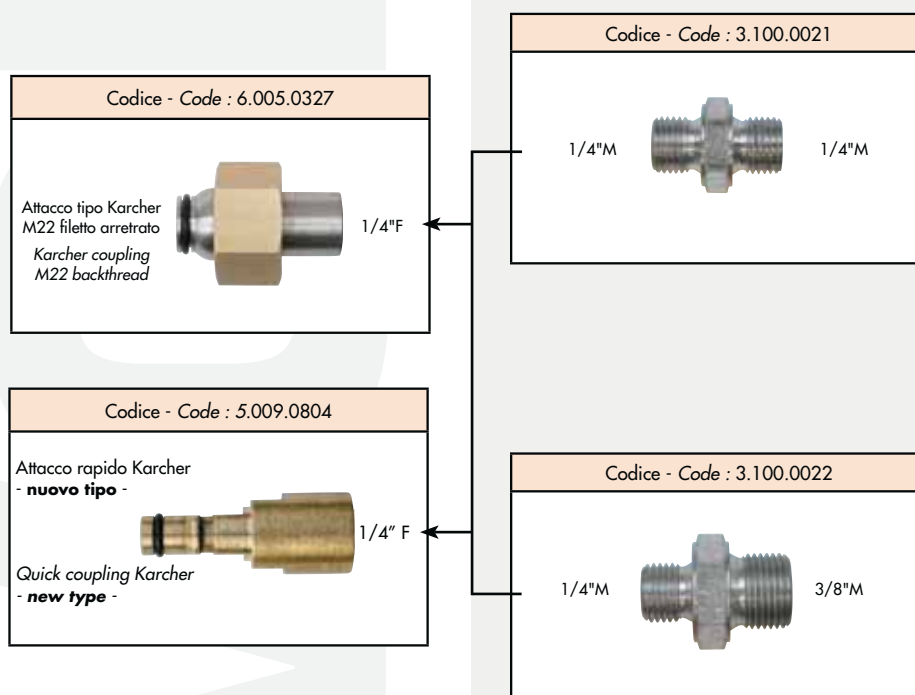

Codice - Code : 5.009.0812

Attacco rapido Karcher
- nuovo tipo -



M22
Ø15

Quick coupling Karcher
- new type -

Codice - Code : 5.009.0800



M22
Ø15

Innesto rapido Lavor
Lavor quick coupling

Codice - Code : 4.606.0053



3/8" M

M22
Ø15

Codice - Code : 4.006.0062

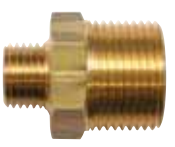

1/4" M

M22
Ø15

Codice - Code : 3.100.0018



3/8" M

1/2" M
Ø11

Codice - Code : 3.749.0258



M24 Ø14

3/8" M

Codice - Code : 6.605.0124



M22F
Ø14

M22
Ø15

Codice - Code : 3.749.0257



M24M
Ø14

3/8" F

Codice - Code : 3.100.0023

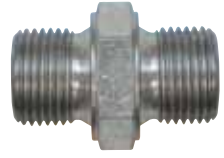

3/8" M

3/8" M

Codice - Code : 3.749.0320



M24M
Ø14

1/4" F

Codice - Code : 3.100.0021



1/4" M

1/4" M

Codice - Code : 3.749.0430



M24F
Ø14

1/4" F

Codice - Code : 3.100.0022

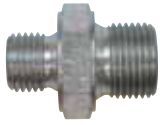

1/4" M

3/8" M

Sonde spurgatubi ad alta pressione per idropultrici hobby

Pipe cleaning hoses for domestic high pressure cleaners



Codice Code	Descrizione Description	Lunghezza Length	Pressione massima Max. pressure			Attacco Coupling	Uscita Outlet
			bar	psi	MPa		
6.003.0037	Sonda spurgatubi con ugello Pipe cleaning hose with nozzle Ø 5/16"	6	160	2320	16	Baionetta Bayonet Lavor	Ugello ottone Brass nozzle
6.003.0048	Sonda spurgatubi con ugello Pipe cleaning hose with nozzle Ø 5/16"	10	160	2320	16	Baionetta Bayonet Lavor	Ugello ottone Brass nozzle
6.003.0052	Sonda spurgatubi con ugello Pipe cleaning hose with nozzle Ø 5/16"	15	160	2320	16	Baionetta Bayonet Lavor	Ugello ottone Brass nozzle



Codice Code	Descrizione Description	Lunghezza Length	Pressione massima Max. pressure			Attacco Coupling	Uscita Outlet
			bar	psi	MPa		
6.003.0015	Sonda spurgatubi con ugello Pipe cleaning hose with nozzle Ø 5/16"	6	160	2320	16	M22M	Ugello ottone Brass nozzle
6.003.0018	Sonda spurgatubi con ugello Pipe cleaning hose with nozzle Ø 5/16"	10	160	2320	16	M22M	Ugello ottone Brass nozzle



Pagina 12-13-16
Page

Ricambi per sonde spurgatubi hobby

Spare parts for domestic pipe cleaning hoses



Codice Code	Descrizione Description	Attacco Coupling	
		A	B
4.006.0216	Ugello spurgatubi con fori laterali Pipe cleaning nozzle with side holes	1/8" F	---
5.009.0421	Attacco a baionetta Bayonet coupling	1/4" M	Baionetta Bayonet Lavor
6.003.0045	Attacco M22 M22 coupling	Baionetta Bayonet Lavor	M22



NEW



PRO



PRO

Sonde spurgatubi ad alta pressione per idropultrici professionali

Pipe cleaning hoses for professional high pressure cleaners

Codice Code	Descrizione Description	Lunghezza Length	Pressione massima Max. pressure			Ingresso Inlet	Uscita Outlet
			bar	psi	MPa		
		m					
6.608.0047	Kit sonda spurgatubi con ugello Kit pipe cleaning hose with nozzle	10	210	3045	21	Innesto rapido Quick coupling	Ugello inox Stainless steel nozzle
6.608.0048	Kit sonda spurgatubi con ugello Kit pipe cleaning hose with nozzle	20	210	3045	21	Innesto rapido Quick coupling	Ugello inox Stainless steel nozzle

Codice Code	Descrizione Description	Lunghezza Length	Pressione massima Max. pressure			Ingresso Inlet	Uscita Outlet
			bar	psi	MPa		
		m					
6.608.0054	Kit sonda spurgatubi con ugello Kit pipe cleaning hose with nozzle	10	210	3045	21	M22M	Ugello inox Stainless steel nozzle
6.608.0045	Kit sonda spurgatubi con ugello Kit pipe cleaning hose with nozzle	20	210	3045	21	M22M	Ugello inox Stainless steel nozzle

Ricambi per sonde spurgatubi professionali

Spare parts for professional pipe cleaning hoses

Codice Code	Descrizione Description	Attacco Coupling	
		A	B
3.103.0035	Ugello spurgatubi con fori laterali Pipe cleaning nozzle with side holes	3/8" M	---
3.749.0474	Attacco a baionetta Bayonet coupling	Innesto rapido Quick coupling	1/4" F
4.006.0099	Attacco M22 M22 coupling	1/4" F	M22 Ø14



A



B

A



B

A

NEW

Testina ugello intercambiabile con attacco rapido a scatto - getto fisso a ventaglio - per idropulitrici hobby

Interchangeable nozzle head with quick coupling - fixed flow - for domestic high pressure cleaners

25°



Codice Code	Descrizione Description	Pressione Pressure			Portata Flow rate		Attacco Coupling	Temperatura Temperature	
		bar	psi	MPa	l/m	GPM		°C	°F
6.002.0341	Testina ugello - Rosa Nozzle head - Pink	150	2175	15	5,7	1,51	Rapido Quick Lavor	40	104
6.002.0342	Testina ugello - Arancio Nozzle head - Orange	150	2175	15	6	1,59	Rapido Quick Lavor	40	104
6.002.0343	Testina ugello - Azzurro Nozzle head - Light blue	150	2175	15	7	1,85	Rapido Quick Lavor	40	104
6.002.0344	Testina ugello - Nero Nozzle head - Black	150	2175	15	7,25	1,92	Rapido Quick Lavor	40	104
6.002.0345	Testina ugello - Verde Nozzle head - Green	150	2175	15	8,3	2,20	Rapido Quick Lavor	40	104

CLICK



Lancia per testina ugello intercambiabile con attacco rapido a scatto - per idropulitrici hobby

Lance for interchangeable nozzle head with quick coupling - for domestic high pressure cleaners

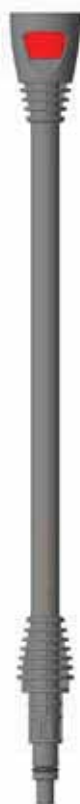

Codice Code	Descrizione Description	Pressione Pressure			Portata Flow rate		Lunghezza Length	Attacco Coupling	Temperatura Temperature	
		bar	psi	MPa	l/m	GPM			mm	A
6.002.0340	Lancia per testina ugello intercambiabile Lance for interchangeable nozzle head	150	2175	15	15	3,97	360	Baionetta Bayonet	40	104

Attacco a baionetta tipo Lavor - disegno tecnico

Bayonet coupling Lavor type - technical drawing

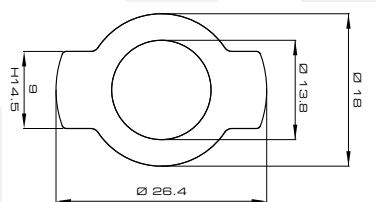

Anello O-Ring di ricambio per baionetta Lavor

Spare O-Ring for Lavor bayonet coupling Lavor



(9.13 x 2.62)

Codice - Code :
3.200.0017



Pagina
Page
12-13-16

Attacco a baionetta tipo Lavor - disegno tecnico

Bayonet coupling Lavor type - technical drawing

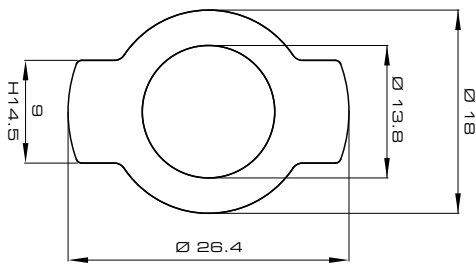

Anello O-Ring di ricambio per baionetta Lavor

Spare O-Ring for Lavor bayonet coupling Lavor



Codice - Code :
3.200.0017

Pagina 12-13-16
Page



Lance in plastica con getto fisso a ventaglio per idropulitrici hobby

Lances with fixed flow for domestic high pressure cleaners



Codice Code	Descrizione Description	Pressione Pressure			Portata Flow rate		Lunghezza Length	Attacco Coupling	Temperatura Temperature	
		bar	psi	MPa	l/m	GPM			mm	A
6.002.0326	Lancia S'02V 0,9 - Rosa Lance S'02V 0,9 - Pink	150	2175	15	5,7	1,51	470	Baionetta Bayonet	40	104
6.002.0262	Lancia S'02V 0,95 - Arancio Lance S'02V 0,95 - Orange	150	2175	15	6	1,59	470	Baionetta Bayonet	40	104
6.002.0263	Lancia S'02V 1,00 - Azzurro Lance S'02V 1,00 - Light blue	150	2175	15	7	1,85	470	Baionetta Bayonet	40	104
6.002.0315	Lancia S'02V 1,15 - Giallo Lance S'02V 1,15 - Yellow	150	2175	15	9,9	2,62	470	Baionetta Bayonet	40	104
6.002.0323	Lancia S'02V 1,20 - Rosso Lancia S'02V 1,20 - Red	150	2175	15	11,2	2,96	470	Baionetta Bayonet	40	104

Lance in plastica a getto variabile per idropulitrici hobby

Plastic lances with variable flow for domestic high pressure cleaners



Codice Code	Descrizione Description	Pressione Pressure			Portata Flow rate		Lunghezza Length	Attacco Coupling	Temperatura Temperature	
		bar	psi	MPa	l/m	GPM			mm	A
6.002.0208C	Lancia S'99 1,00 - Azzurro Lance S'99 1,00 - Light blue	150	2175	15	7	1,85	470	Baionetta Bayonet	40	104
6.002.0217C	Lancia S'99 1,025 - Nero Lance S'99 1,025 - Black	150	2175	15	7,25	1,92	470	Baionetta Bayonet	40	104
6.002.0209C	Lancia S'99 1,05 - Grigio Lance S'99 1,05 - Grey	150	2175	15	7,5	1,98	470	Baionetta Bayonet	40	104
6.002.0210C	Lancia S'99 1,10 - Verde Lance S'99 1,10 - Green	150	2175	15	8,3	2,20	470	Baionetta Bayonet	40	104
6.002.0211C	Lancia S'99 1,15 - Giallo Lance S'99 1,15 - Yellow	150	2175	15	9,9	2,62	470	Baionetta Bayonet	40	104
6.002.0212C	Lancia S'99 1,20 - Rosso Lance S'99 1,20 - Red	150	2175	15	11,2	2,96	470	Baionetta Bayonet	40	104
6.002.0213C	Lancia S'99 1,25 - Bianco Lance S'99 1,25 - White	150	2175	15	11,8	3,12	470	Baionetta Bayonet	40	104
6.002.0214C	Lancia S'99 1,30 - Blu Lance S'99 1,30 - Blue	150	2175	15	12,5	3,31	470	Baionetta Bayonet	40	104

Lance a getto variabile alta/bassa pressione per idropulitrici hobby

Lances with variable flow high/low pressure for domestic high pressure cleaners



Codice Code	Descrizione Description	Pressione Pressure			Portata Flow rate		Lunghezza Length mm	Attacco Coupling A	Temperatura Temperature	
		bar	psi	MPa	l/m	GPM			°C	°F
6.002.0286	Lancia S'99 0,95 A/B - Arancio Lance S'99 0,95 H/L - Orange	150	2175	15	6	1,59	500	Baionetta Bayonet	40	104
6.002.0189C	Lancia S'99 1,00 A/B - Azzurro Lance S'99 1,00 H/L - Light blue	150	2175	15	7	1,85	500	Baionetta Bayonet	40	104
6.002.0191C	Lancia S'99 1,10 A/B - Verde Lance S'99 1,10 H/L - Green	150	2175	15	8,3	2,20	470	Baionetta Bayonet	40	104
6.002.0192C	Lancia S'99 1,15 A/B - Giallo Lance S'99 1,15 H/L - Yellow	150	2175	15	9,9	2,62	500	Baionetta Bayonet	40	104
6.002.0193C	Lancia S'99 1,20 A/B - Rosso Lance S'99 1,20 H/L - Red	150	2175	15	11,2	2,96	470	Baionetta Bayonet	40	104
6.002.0194C	Lancia S'99 1,25 A/B - Bianco Lance S'99 1,25 H/L - White	150	2175	15	11,8	3,12	470	Baionetta Bayonet	40	104
6.002.0195C	Lancia S'99 1,30 A/B - Blu Lance S'99 1,30 H/L - Blue	150	2175	15	12,5	3,31	470	Baionetta Bayonet	40	104

Lance a getto variabile alta/bassa pressione in ottone per idropulitrici hobby/pro

Brass lances with variable flow high/low pressure for domestic /pro high pressure cleaners



Codice Code	Descrizione Description	Pressione Pressure			Portata Flow rate		Lunghezza Length mm	Attacco Coupling A	Temperatura Temperature	
		bar	psi	MPa	l/m	GPM			°C	°F
6.002.0182	Lancia SY'99 1,00 A/B - Azzurro Lance SY'99 1,00 H/L - Light blue	150	2175	15	7	1,85	500	Baionetta Bayonet	90	194
6.002.0184	Lancia SY'99 1,10 A/B - Verde Lance SY'99 1,10 H/L - Green	150	2175	15	8,3	2,20	500	Baionetta Bayonet	90	194
6.002.0186	Lancia SY'99 1,20 A/B - Rosso Lance SY'99 1,20 H/L - Red	150	2175	15	11,2	2,96	500	Baionetta Bayonet	90	194
6.002.0188	Lancia SY'99 1,30 A/B - Blu Lance SY'99 1,30 H/L - Blue	150	2175	15	12,5	3,31	500	Baionetta Bayonet	90	194

Anelli O-Ring di ricambio per lance Lavor

Spare O-Ring for Lavor lances



(9.13 x 2.62)

Codice - Code :

3.200.0017

Anello O-Ring di ricambio per baionetta
Spare O-Ring for bayonet coupling

Anelli O-Ring di ricambio per testina alta/bassa pressione
Spare O-Rings for high/low pressure lance head



Codice - Code :

3.200.0016

(8.73 x 1.78)

Codice - Code :

3.200.0055

(7.66 x 1.78)

Codice - Code :

3.200.0004

(12.4 x 1.78)

Lance in ottone/acciaio alta/bassa pressione per idropultrici hobby a caldo

Brass/steel lances high/low pressure for domestic hot water high pressure cleaners



Codice Code	Descrizione Description	Pressione Pressure			Portata Flow rate		Lunghezza Length	Attacco Coupling	Temperatura Temperature	
		bar	psi	MPa	l/m	GPM			mm	A
6.002.0310	Lancia senza copertura A/B 1,00 - Azzurro Lance without cover H/L 1,00 - Light blue	150	2175	15	7	1,85	500	M22 Ø14	90	194
6.002.0261	Lancia senza copertura A/B 1,025 - Nero Lance without cover H/L 1,025 - Black	150	2175	15	7,25	1,92	500	M22 Ø14	90	194
6.002.0309	Lancia senza copertura A/B 1,10 Lance without cover H/L 1,10	150	2175	15	8,3	2,20	500	M22 Ø14	90	194
6.002.0260	Lancia senza copertura A/B 1,15 Lance without cover H/L 1,15	150	2175	15	9,9	2,62	500	M22 Ø14	90	194
6.002.0295	Lancia con copertura 1,15 A/B - Giallo Lance with cover 1,15 A/B - Yellow	150	2175	15	9,9	2,62	500	M22 Ø14	90	194
6.002.0242	Lancia senza copertura A/B 1,30 - Blu Lance without cover H/L 1,30 - Blue	150	2175	15	12,5	3,31	500	M22 Ø14	90	194

Raccordo di ricambio per lance M22

Spare coupling for lances M22



Anelli O-Ring di ricambio per testina alta/bassa pressione

Spare O-Rings for high/low pressure lance head



Codice - Code : 3.200.0119 Viton (7.66 x 1.78)	Codice - Code : 3.200.0121 Viton (8.73 x 1.78)	Codice - Code : 3.200.0120 Viton (12.4 x 1.78)
--	--	--

Lance curve per idropultrici hobby a freddo e caldo

Curved lances for domestic cold and hot water high pressure cleaners

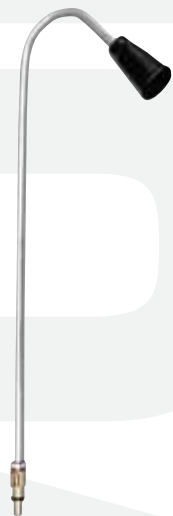

Codice Code	Descrizione Description	Pressione Pressure			Portata Flow rate		Lunghezza Length	Attacco Coupling	Temperatura Temperature	
		bar	psi	MPa	l/m	GPM			mm	A
6.002.0256	Lancia curva 45° - Ugello 15045 Curved lance 45° - Nozzle 15045	150	2175	15	12,5	3,31	750	Baionetta Bayonet	90	194
6.002.0203	Lancia curva 45° - Ugello 15035 Curved lance - Nozzle 15035	150	2175	15	9,9	2,62	750	Baionetta Bayonet	90	194
6.002.0013	Lancia curva - Ugello 15045 Curved lance - Nozzle 15045	150	2175	15	12,5	3,31	750	Baionetta Bayonet	90	194
6.602.0019	Lancia curva lavaggio sottoscocca - senza ugello Curved lance for underbody wash - without nozzle	200	2900	20	---	---	750	M22 Ø14	150	302

Per gli ugelli vedi pag. 35
For nozzles see page 35

Lance per idropultrici hobby

Lances for domestic high pressure cleaners

A



Codice Code	Descrizione Description	Pressione Pressure			Lunghezza Length	Attacco Coupling	Attacco Coupling	Temperatura Temperature	
		bar	psi	MPa				°C	°F
6.002.0322	Lancia portaugello con attacco rapido Nozzle holder lance with nozzle quick coupling	200	2900	20	500	Rapido Quick	M22 Ø14	90	194
6.002.0325	Lancia portaugello con attacco rapido Nozzle holder lance with nozzle quick coupling	200	2900	20	500	Rapido Quick	Baionetta Bayonet	90	194
6.602.0032	Lancia dritta senza portaugello Straight lance without nozzle head	200	2900	20	500	1/4" M	M22 Ø14	150	302

Testina rotante ad innesto rapido per lancia

Rotating nozzle head with quick coupling for lance



Attacco rapido 1/4" M per raccordo girevole

Quick coupling 1/4" M for swivel coupling

Codice - Code :
4.607.0275



B



Codice - Code :
6.002.0332

150 bar
11.5 l/min

Anello O-Ring di ricambio per baionetta Lavor

Spare O-Ring for Lavor bayonet coupling

Raccordo a baionetta Lavor con O-Ring

Spare Lavor bayonet coupling with O-Ring



(9.13 x 2.62)

Codice - Code :
3.200.0017

Anello O-Ring di ricambio per baionetta
Spare O-Ring for bayonet coupling

Codice - Code :
5.009.0300

1/4" F



Ugelli ad alta pressione con attacco rapido Lavor

High pressure nozzles with Lavor quick coupling

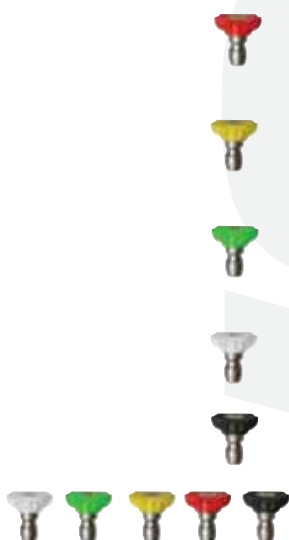

Codice Code	Descrizione Description	Angolo Angle	Foro Hole
			mm
3.103.0076	Ugello alta pressione - Rosso / High pressure nozzle - Red	0°	1.10
3.103.0071	Ugello alta pressione - Rosso / High pressure nozzle - Red	0°	1.20
3.103.0077	Ugello alta pressione - Giallo / High pressure nozzle - Yellow	15°	1.10
3.103.0072	Ugello alta pressione - Giallo / High pressure nozzle - Yellow	15°	1.20
3.103.0078	Ugello alta pressione - Verde / High pressure nozzle - Green	25°	1.10
3.103.0073	Ugello alta pressione - Verde / High pressure nozzle - Green	25°	1.20
3.103.0079	Ugello alta pressione - Bianco / High pressure nozzle - White	40°	1.10
3.103.0074	Ugello alta pressione - Bianco / High pressure nozzle - White	40°	1.20
3.103.0075	Ugello bassa pressione - Nero / Low pressure nozzle - Black	40°	---
5.012.0281	Kit 5 ugelli foro 1.10 / Kit 5 nozzles hole 1.10	---	1.10
5.012.0282	Kit 5 ugelli foro 1.20 / Kit 5 nozzles hole 1.20	---	1.20

NEW

Testina rotox intercambiabile con attacco rapido a scatto - per idropulitrici hobby

Interchangeable rotox nozzle head with quick coupling - for domestic high pressure cleaners



Codice Code	Descrizione Description	Pressione Pressure			Portata Flow rate		Attacco Coupling	Temperatura Temperature	
		bar	psi	MPa	l/m	GPM		°C	°F
6.002.0346	Testina rotox - Nero Rotox nozzle head - Black	150	2175	15	7,25	1,92	Rapido Quick Lavor	40	104
6.002.0347	Testina rotox - Verde Rotox nozzle head - Green	150	2175	15	8,3	2,20	Rapido Quick Lavor	40	104



Lancia per testina ugello intercambiabile con attacco rapido a scatto - per idropulitrici hobby

Lance for interchangeable nozzle head with quick coupling - for domestic high pressure cleaners

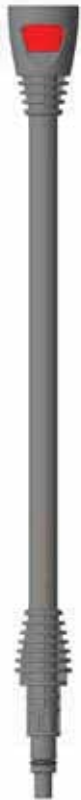

Codice Code	Descrizione Description	Pressione Pressure			Portata Flow rate		Lunghezza Length	Attacco Coupling	Temperatura Temperature	
		bar	psi	MPa	l/m	GPM			mm	°C
6.002.0340	Lancia per testina ugello intercambiabile Lance for interchangeable nozzle head	150	2175	15	15	3,97	360	Baionetta Bayonet	40	104

Attacco a baionetta tipo Lavor - disegno tecnico

Bayonet coupling Lavor type - technical drawing

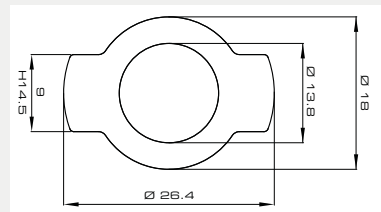

Pagina Page 12-13-16

Anello O-Ring di ricambio per baionetta Lavor

Spare O-Ring for Lavor bayonet coupling Lavor



Codice - Code :
3.200.0017

(9.13 x 2.62)



Pagina
Page
12-13-16



Lance rotox in plastica per idropulitrici hobby

Plastic rotox lances for domestic high pressure cleaners



Codice Code	Descrizione Description	Pressione Pressure			Portata Flow rate		Lunghezza Length	Attacco Coupling	Temperatura Temperature	
		bar	psi	MPa	l/m	GPM			mm	A
6.002.0329	Lancia rotox 1,025 - nero Rotox lance 1,025 - black	150	2175	15	7,25	1,92	470	Baionetta Bayonet	40	104
6.002.0327	Lancia rotox 1,10 - verde Rotox lance 1,10 - green	150	2175	15	8,3	2,20	470	Baionetta Bayonet	40	104
6.002.0328	Lancia rotox 1,20 - rosso Rotox lance 1,20 - red	150	2175	15	11,2	2,96	470	Baionetta Bayonet	40	104
6.002.0232	Lancia rotox 1,25 - bianco Rotox lance 1,25 - white	150	2175	15	11,8	3,12	470	Baionetta Bayonet	40	104



Lance rotox in ottone per idropulitrici hobby

Brass rotox lances for domestic high pressure cleaners



Codice Code	Descrizione Description	Pressione Pressure			Portata Flow rate		Lunghezza Length	Attacco Coupling	Temperatura Temperature	
		bar	psi	MPa	l/m	GPM			mm	A
6.002.0175	Lancia rotox 1,05 - grigio Rotox lance 1,05 - grey	150	2175	15	7,5	1,98	500	Baionetta Bayonet	90	194
6.002.0223	Lancia rotox 1,20 - rosso Rotox lance 1,20 - red	150	2175	15	11,2	2,96	500	Baionetta Bayonet	90	194
6.002.0176	Lancia rotox 1,30 - blu Rotox lance 1,30 - blue	150	2175	15	12,5	3,31	500	Baionetta Bayonet	90	194



Lance rotox M22 in ottone per idropulitrici hobby

Brass rotox M22 lances for domestic high pressure cleaners



Codice Code	Descrizione Description	Pressione Pressure			Portata Flow rate		Lunghezza Length	Attacco Coupling	Temperatura Temperature	
		bar	psi	MPa	l/m	GPM			mm	A
6.002.0246	Lancia rotox 1,20 - rosso Rotox lance 1,20 - red	150	2175	15	11,2	2,96	500	M22 Ø14	90	194
6.002.0165	Lancia rotox 1,25 - bianco Rotox lance 1,25 - white	150	2175	15	11,8	3,12	500	M22 Ø14	90	194

Raccordo di ricambio per lance M22

Spare coupling for lances M22



Codice - Code :
4.006.0099

Anello O-Ring di ricambio per baionetta Lavor

Spare O-Ring for Lavor bayonet coupling Lavor



(9.13 x 2.62)

Codice - Code :
3.200.0017

Anello O-Ring di ricambio per baionetta
Spare O-Ring for bayonet coupling



Ugelli rotanti ad alta pressione con attacco 1/4" F - attacco rapido

High pressure rotating nozzle heads with coupling 1/4" F - quick coupling

Rimuovibile
Removable



Rimuovibile
Removable

Codice Code	Descrizione Description	Attacco Thread	Foro Hole
			mm
3.749.0295	Ugello rotante professionale Professional rotating nozzle	Rapido Quick Lavor	045
3.749.0466	Ugello rotante professionale Professional rotating nozzle	Rapido Quick Lavor	055
3.749.0467	Ugello rotante professionale Professional rotating nozzle	Rapido Quick Lavor	070
6.002.0332	Ugello rotante hobby Hobby rotating nozzle	Rapido Quick Lavor	1.25

Attacco rapido 1/4" M per raccordo girevole

Quick coupling 1/4" M for swivel coupling

Codice - Code :
4.607.0275



1/8" F



Lance inox con attacco rapido tipo Kew/Lavor - 1/8" F (lato ugello) per idropulitrici professionali

Stainless steel lances with quick coupling Kew/Lavor - 1/8" F (nozzle side) for professional high pressure cleaners

Codice Code	Descrizione Description	Pressione Pressure			Portata Flow rate		Lunghezza Length	Attacco Coupling	Temperatura Temperature		Alta/Bassa pressione High/Low pressure
		bar	psi	MPa	l/m	GPM			mm	A	
6.602.0043	Lancia inox con portaugello Stainless steel lance with nozzle holder	250	3625	25	40	10,5	900	Rapido a sfere Quick ball coupling	150	302	---
6.602.0044	Lancia inox con testina A/B pressione Stainless steel lance with H/L head	250	3625	25	40	10,5	900	Rapido a sfere Quick ball coupling	150	302	X
6.602.0047	Lancia inox con portaugello Stainless steel lance with nozzle holder	250	3625	25	40	10,5	1700	Rapido a sfere Quick ball coupling	150	302	---
6.602.0046	Lancia inox con testina A/B pressione Stainless steel lance with H/L head	250	3625	25	40	10,5	1700	Rapido a sfere Quick ball coupling	150	302	X

A:
Quick
Ball coupling

Per gli ugelli vedi pag. 35
For nozzles see page 35

A:
Quick
Ball coupling



1/4" F

Riduzione 1/4" M - 1/8" F
Reduction nipple 1/4" M - 1/8" F



Codice - Code:
3.100.0009

Lance inox con attacco rapido tipo Kew/Lavor - 1/4" F (lato ugello) per idropulitrici professionali

Stainless steel lances with quick coupling Kew/Lavor - 1/4" F (nozzle side)
for professional high pressure cleaners

Codice Code	Descrizione Description	Pressione Pressure			Portata Flow rate		Lunghezza Length	Attacco Coupling	Temperatura Temperature		Alta/Bassa pressione High/Low pressure
		bar	psi	MPa	l/m	GPM			mm	A	
6.602.0045	Lancia inox con portaugello Stainless steel lance with nozzle holder	250	3625	25	40	10.5	900	Rapido a sfere Quick ball coupling	150	302	---

Per gli ugelli vedi pag. 35
For nozzles see page 35

A:
Quick
Ball coupling



1/4" M

**Testina alta/bassa pressione
per ugello**
High/low pressure nozzle head



1/4" F

Codice - Code :
3.749.0011

Lance inox con attacco rapido tipo Kew/Lavor - 1/4" M per testina portaugello per idropulitrici professionali

Stainless steel lances with quick coupling Kew/Lavor - 1/4" M for nozzle head for professional
high pressure cleaners

Codice Code	Descrizione Description	Pressione Pressure			Portata Flow rate		Lunghezza Length	Attacco Coupling	Temperatura Temperature		Alta/Bassa pressione High/Low pressure
		bar	psi	MPa	l/m	GPM			mm	A	
6.602.0048	Lancia inox senza portaugello Stainless steel lance without nozzle holder	250	3625	25	40	10.5	700	Rapido a sfere Quick ball coupling	150	302	---

Per gli ugelli vedi pag. 35
For nozzles see page 35

1/8" F



Lance inox con attacco 1/4" M - 1/8" F (lato ugello) per idropulitrici professionali

Stainless steel lances with coupling 1/4" M - 1/8" F (nozzle side) for professional high pressure cleaners

Codice Code	Descrizione Description	Pressione Pressure			Portata Flow rate		Lunghezza Length	Attacco Coupling	Temperatura Temperature		Alta/Bassa pressione High/Low pressure
		bar	psi	MPa	l/m	GPM			mm	A	
6.602.0050	Lancia inox con portaugello Stainless steel lance with nozzle holder	250	3625	25	40	10.5	1700	1/4" M	150	302	---
6.602.0049	Lancia inox con testina A/B pressione Stainless steel lance with H/L head	250	3625	25	40	10.5	1700	1/4" M	150	302	X
3.501.0027	Lancia inox con portaugello Stainless steel lance with nozzle holder	250	3625	25	40	10.5	2000	1/4" M	150	302	---
3.501.0032	Lancia inox con testina A/B pressione Stainless steel lance with H/L head	250	3625	25	40	10.5	2000	1/4" M	150	302	X

A:
1/4" M

Per gli ugelli vedi pag. 35
For nozzles see page 35

Lance inox con attacco M22Ø14 - 1/8" F (lato ugello) per idropulitrici professionali

Stainless steel lances with coupling M22 Ø14 - 1/8" F (nozzle side) for professional high pressure cleaners

Codice Code	Descrizione Description	Pressione Pressure			Portata Flow rate		Lunghezza Length	Attacco Coupling		Temperatura Temperature		Alta/Bassa pressione High/Low pressure
		bar	psi	MPa	l/m	GPM		mm	A	B	°C	
3.701.0015	Lancia inox con testina A/B pressione <i>Stainless steel lance with H/L head</i>	250	3625	25	40	10,5	700	M22 Ø14	1/8" F	150	302	X
3.708.0001	Lancia inox con portaugello <i>Stainless steel lance with nozzle holder</i>	250	3625	25	40	10,5	700	M22 Ø14	1/8" F	150	302	---
3.701.0023	Lancia inox con testina A/B pressione <i>Stainless steel lance with H/L head</i>	250	3625	25	40	10,5	700	M22 Ø14	1/4" F	150	302	X

A:
M22 Ø14

B

Testina alta/bassa pressione per ugello
High/low pressure nozzle head



Codice - Code :
3.749.0011

Per gli ugelli vedi pag. 35
For nozzles see page 35

Lance doppie con manopola di regolazione per idropulitrici professionali

Double lances with regulator knob for professional high pressure cleaners

Codice Code	Descrizione Description	Pressione Pressure			Portata Flow rate		Lunghezza Length	Attacco Coupling	Temperatura Temperature	
		bar	psi	MPa	l/m	GPM			mm	A
3.701.0025	Lancia doppia con manopola di regolazione <i>Double lance with regulator knob</i>	250	3625	25	40	10,5	550	M22 Ø14	150	302

A:
M22 Ø14

1/8" F

Per gli ugelli vedi pag. 35
For nozzles see page 35

Lance rotox per idropulitrici professionali

Rotating lances for professional high pressure cleaners

Codice Code	Descrizione Description	Pressione Pressure			Portata Flow rate		Lunghezza Length	Attacco Coupling	Temperatura Temperature		Testina di ricambio (*) Spare nozzle head (*)
		bar	psi	MPa	l/m	GPM			mm	A	
6.602.0040	Lancia turbo rotox - 045 <i>Turbo lance rotox - 045</i>	150	2175	15	11	2,91	550	M22 Ø14	150	302	3.749.0295
6.602.0041	Lancia turbo rotox - 055 <i>Turbo lance rotox - 055</i>	200	2900	20	15	3,96	550	M22 Ø14	150	302	3.749.0466
6.602.0042	Lancia turbo rotox - 070 <i>Turbo lance rotox - 070</i>	250	3625	25	21	5,55	550	M22 Ø14	150	302	3.749.0467

A:
M22 Ø14

(*) Per gli ugelli rotanti vedi pag. 31
() For rotating nozzle heads see page 31*

Pistola con lancia estensibile telescopica per idropultrici professionali

Gun with extensible telescopic lance for professional high pressure cleaners

NEW

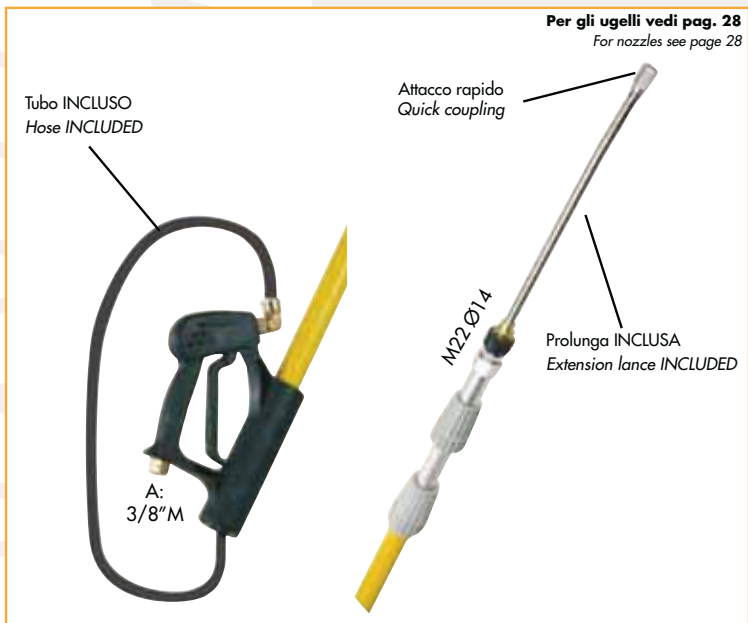

Codice Code	Descrizione Description	Pressione Pressure			Portata Flow rate		Lunghezza Length		Attacco Coupling	Temperatura Temperature	
		bar	psi	MPa	l/m	GPM	min (mm)	max (mm)		A	°C
3.749.0488	Pistola con lancia estensibile telescopica Gun with extensible telescopic lance	250	3625	25	40	10,5	2000	5000	3/8" M	150	302



Per le spazzole rotanti vedi pag. 42
For rotating brushes see page 42



Per le lance curve vedi pag. 27
For curved lances see page 27

Prolunga di ricambio per pistola con lancia estensibile telescopica

Spare extension lance for gun with extensible telescopic lance

Codice Code	Descrizione Description	Pressione Pressure			Portata Flow rate		Lunghezza Length	Attacco Coupling	Attacco Coupling	Temperatura Temperature	
		bar	psi	MPa	l/m	GPM				min (mm)	A
6.002.0322	Prolunga Extension lance	250	3625	25	40	10,5	500	M22 Ø14	Rapido Quick Lavor	150	302

Tubo di ricambio per pistola con lancia estensibile telescopica

Spare hose for gun with extensible telescopic lance



8 m

Codice - Code :
4.018.0067
Tubo di ricambio 8 m
Spare hose 8 m

+ Codice - Code :
3.100.0021
+ Raccordo 1/4" M-1/4" M
Coupling 1/4" M-1/4" M

+ Codice - Code :
3.100.0022
+ Raccordo 1/4" M-3/8" M
Coupling 1/4" M-3/8" M

Ugelli ad alta pressione in acciaio temperato Tempered steel high pressure nozzles



1/8" M

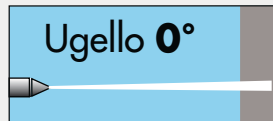

Ugello 0°	
Codice Code	Foro Hole
3.103.0027	030
3.103.0037	035
3.103.0028	040
3.103.0034	045
3.103.0029	050
3.103.0030	055
3.103.0031	060
3.103.0024	065
3.103.0025	070
3.103.0070	075
3.103.0026	080
3.103.0033	090

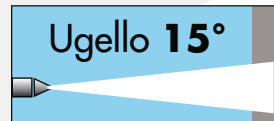

Ugello 15°	
Codice Code	Foro Hole
3.103.0013	020
3.103.0046	025
3.103.0047	030
3.103.0048	035
3.103.0049	040
3.103.0050	045
3.103.0051	050
3.103.0052	055
3.103.0053	060
3.103.0054	065
3.103.0055	070
3.103.0056	075
3.103.0057	080
3.103.0058	085
3.103.0059	090



Ugello 25°	
Codice Code	Foro Hole
3.103.0018	030
3.103.0020	035
3.103.0009	040
3.103.0016	045
3.103.0017	050
3.103.0019	055
3.103.0021	060
3.103.0066	065
3.103.0067	070
3.103.0068	075
3.103.0069	090



1/4" M



Ugello 15°	
Codice Code	Foro Hole
3.103.0093	030
3.103.0081	035
3.103.0082	040
3.103.0083	045
3.103.0084	050
3.103.0085	055
3.103.0086	060
3.103.0087	065
3.103.0088	070
3.103.0089	075
3.103.0090	080
3.103.0023	100



Ugello 25°	
Codice Code	Foro Hole
3.103.0108	030
3.103.0109	035
3.103.0110	045
3.103.0111	050
3.103.0112	055
3.103.0113	060
3.103.0114	065

Ugello a lama 1/8" M Soap nozzle 1/8" M

1/8" M



Codice - Code :
3.103.0011

Riduzione 1/4" M - 1/8" F Reduction nipple 1/4" M - 1/8" F

1/4" M



1/8" F

Codice - Code :
3.100.0009

**TABELLA DELLE PORTATE COMPARATE CON LE PRESSIONI D'ESERCIZIO E IL TIPO DI UGELLO UTILIZZATO
OUTPUT IN L/MIN. AT THE INDICATED PRESSURE AND NOZZLE**

TIPO UGELLO NOZZLE TYPE	Ø mm	20		40		60		80		100		120		150		200		225		250		275		300		325		350		375		400		
		l/m	BAR	l/m	BAR	l/m	BAR	l/m	BAR	l/m	BAR	l/m	BAR	l/m	BAR	l/m	BAR	l/m	BAR	l/m	BAR	l/m	BAR	l/m	BAR	l/m	BAR	l/m	BAR	l/m	BAR	l/m	BAR	
015	0,80	1,5	2,1	2,6	3,0	3,4	3,7	4,1	4,8	5,0	5,3	5,6	5,8	6,0	6,3	6,5	6,7	6,9	7,1	7,4	7,7	8,1	8,4	8,7	8,9	9,1	9,4	9,7	10,0	10,3	10,6	10,9	11,2	
02	0,90	2,0	2,8	3,5	4,0	4,5	4,9	5,5	6,3	6,7	7,1	7,4	7,7	8,1	8,4	8,7	9,0	9,3	9,6	10,0	10,6	11,1	11,6	12,1	12,5	13,0	13,4	13,8	14,2	14,6	15,0	15,4	15,8	
03	1,10	3,1	4,3	5,3	6,2	6,8	7,4	8,3	9,6	10,1	10,6	11,1	11,6	12,1	12,5	13,0	13,4	13,8	14,2	14,6	15,0	15,4	15,8	16,2	16,6	17,0	17,4	17,8	18,2	18,6	19,0	19,4	19,8	20,2
035	1,15	3,6	5,1	6,2	7,3	8,1	8,8	9,9	11,4	11,7	12,4	13,0	13,6	14,1	14,6	15,2	15,7	16,2	16,7	17,2	17,7	18,2	18,7	19,2	19,7	20,2	20,7	21,2	21,7	22,2	22,7	23,2	23,7	24,2
04	1,20	4,2	5,9	7,1	8,2	9,2	10,0	11,2	13,0	13,4	14,1	14,8	15,5	16,1	16,7	17,3	17,9	18,5	19,1	19,7	20,3	20,9	21,5	22,1	22,7	23,3	23,9	24,5	25,1	25,7	26,3	26,9	27,5	28,1
045	1,30	4,5	6,4	7,8	9,0	10,2	11,1	12,5	14,4	15,1	15,9	16,7	17,4	18,1	18,8	19,5	20,1	20,8	21,5	22,2	22,9	23,6	24,3	25,0	25,7	26,4	27,1	27,8	28,5	29,2	29,9	30,6	31,3	32,0
05	1,35	5,1	7,2	8,7	10,2	11,4	12,5	14,0	16,0	16,8	17,7	18,5	19,4	20,2	20,9	21,7	22,4	23,1	23,8	24,5	25,2	25,9	26,6	27,3	28,0	28,7	29,4	30,1	30,8	31,5	32,2	32,9	33,6	34,3
055	1,40	5,5	7,8	9,5	11,0	12,4	13,5	15,0	17,5	18,1	18,8	19,5	20,1	20,9	21,8	22,5	23,2	23,9	24,6	25,3	26,0	26,7	27,4	28,1	28,8	29,5	30,2	30,9	31,6	32,3	33,0	33,7	34,4	35,1
06	1,50	6,0	8,5	10,5	12,2	13,8	15,0	17,0	19,5	20,1	21,2	22,2	23,2	24,2	25,1	26,0	26,8	27,7	28,6	29,5	30,4	31,3	32,2	33,1	34,0	34,9	35,8	36,7	37,6	38,5	39,4	40,3	41,2	42,1
065	1,55	6,6	9,3	11,4	13,2	14,7	16,0	18,0	20,7	21,5	22,6	23,5	24,7	25,4	26,5	27,4	28,5	29,4	30,3	31,2	32,1	33,0	33,9	34,8	35,7	36,6	37,5	38,4	39,3	40,2	41,1	42,0	42,9	43,8
07	1,60	7,0	10,0	12,4	14,3	16,0	17,6	20,0	22,6	23,5	24,7	26,0	27,1	28,2	29,3	30,3	31,3	32,3	33,3	34,3	35,3	36,3	37,3	38,3	39,3	40,3	41,3	42,3	43,3	44,3	45,3	46,3	47,3	48,3
075	1,65	7,6	10,7	13,0	15,2	17,0	18,6	20,8	24,0	24,7	25,6	26,3	27,9	28,9	30,0	31,0	32,3	33,3	34,3	35,3	36,3	37,3	38,3	39,3	40,3	41,3	42,3	43,3	44,3	45,3	46,3	47,3	48,3	49,3
08	1,70	8,1	11,6	14,2	16,6	18,5	20,2	23,0	26,0	26,8	28,3	29,7	31,0	32,2	33,5	34,6	35,8	36,9	38,0	39,1	40,2	41,3	42,4	43,5	44,6	45,7	46,8	47,9	49,0	50,1	51,2	52,3	53,4	54,5
085	1,75	8,5	12,2	14,9	17,3	19,2	21,0	23,5	27,0	28,0	29,1	30,2	31,4	32,2	33,8	34,8	36,3	37,3	38,3	39,3	40,3	41,3	42,3	43,3	44,3	45,3	46,3	47,3	48,3	49,3	50,3	51,3	52,3	53,3
09	1,80	9,1	12,8	15,7	18,0	20,0	22,0	24,5	28,2	30,2	31,8	33,4	34,9	36,3	37,6	39,0	40,2	41,5	42,8	44,1	45,4	46,7	48,0	49,3	50,6	51,9	53,2	54,5	55,8	57,1	58,4	59,7	61,0	62,3
10	1,90	10,0	14,2	17,4	20,0	22,5	25,0	28,0	32,0	33,0	34,4	35,6	37,0	38,2	39,7	40,2	42,8	44,1	45,4	46,7	48,0	49,3	50,6	51,9	53,2	54,5	55,8	57,1	58,4	59,7	61,0	62,3	63,6	64,9
13	2,20	13,1	18,8	22,6	26,1	29,1	31,8	35,6	41,0	42,9	44,8	46,5	48,7	50,9	53,4	55,1	57,4	59,7	62,0	64,3	66,6	68,9	71,2	73,5	75,8	78,1	80,4	82,7	85,0	87,3	89,6	91,9	94,2	96,5
15	2,40	15,0	21,5	26,5	30,2	34,0	37,2	41,5	48,0	51,0	54,0	56,5	59,1	61,1	63,7	65,2	68,3	70,8	73,3	75,8	78,3	80,8	83,3	85,8	88,3	90,8	93,3	95,8	98,3	100,8	103,3	105,8	108,3	110,8
20	2,70	20,0	28,5	35,5	40,5	45,0	49,0	54,0	63,5	66,0	69,4	72,0	75,6	79,2	82,8	86,4	90,0	93,6	97,2	100,8	104,4	108,0	111,6	115,2	118,8	122,4	126,0	129,6	133,2	136,8	140,4	144,0	147,6	151,2
25	3,00	25,0	35,7	44,0	50,5	56,5	61,8	69,0	80,0	83,0	86,0	89,0	92,0	95,0	98,0	101,0	104,0	107,0	110,0	113,0	116,0	119,0	122,0	125,0	128,0	131,0	134,0	137,0	140,0	143,0	146,0	149,0	152,0	155,0
30	3,30	30,0	43,0	52,5	60,5	67,8	74,2	83,0	95,5	99,5	103,5	107,5	111,5	115,5	119,5	123,5	127,5	131,5	135,5	139,5	143,5	147,5	151,5	155,5	159,5	163,5	167,5	171,5	175,5	179,5	183,5	187,5	191,5	195,5
40	3,80	40,0	57,0	70,0	81,0	90,0	98,5	110,0	127,0	133,0	140,0	148,5	157,0	165,5	174,0	182,5	191,0	199,5	208,0	216,5	225,0	233,5	242,0	250,5	259,0	267,5	276,0	284,5	293,0	301,5	310,0	318,5	327,0	335,5
50	4,20	50,5	72,0	87,5	100,0	112,0	122,0	137,0	158,0	166,0	176,0	186,0	196,0	206,0	216,0	226,0	236,0	246,0	256,0	266,0	276,0	286,0	296,0	306,0	316,0	326,0	336,0	346,0	356,0	366,0	376,0	386,0	396,0	406,0
60	4,70	60,0	86,0	105,0	121,0	136,0	149,0	166,0	192,0	200,0	210,0	220,0	230,0	240,0	250,0	260,0	270,0	280,0	290,0	300,0	310,0	320,0	330,0	340,0	350,0	360,0	370,0	380,0	390,0	400,0	410,0	420,0	430,0	440,0

Ugelli vapore

Nozzles for steam generators



A

Codice Code	Descrizione Description	Attacco Thread	Angolo Angle	Temperatura Temperature		Pressione Pressure		
				°C	°F	bar	psi	MPa
		A						
3.749.0183	Ugello a lama per vapore Blade nozzle for steam	1/4" F	80°	130	266	100	1450	10

Ugelli ad alta pressione con attacco rapido Lavor

High pressure nozzles with Lavor quick coupling

Codice Code	Descrizione Description	Angolo Angle	Foro Hole
			mm
3.103.0076	Ugello alta pressione - Rosso / High pressure nozzle - Red	0°	1.10
3.103.0071	Ugello alta pressione - Rosso / High pressure nozzle - Red	0°	1.20
3.103.0077	Ugello alta pressione - Giallo / High pressure nozzle - Yellow	15°	1.10
3.103.0072	Ugello alta pressione - Giallo / High pressure nozzle - Yellow	15°	1.20
3.103.0078	Ugello alta pressione - Verde / High pressure nozzle - Green	25°	1.10
3.103.0073	Ugello alta pressione - Verde / High pressure nozzle - Green	25°	1.20
3.103.0079	Ugello alta pressione - Bianco / High pressure nozzle - White	40°	1.10
3.103.0074	Ugello alta pressione - Bianco / High pressure nozzle - White	40°	1.20
3.103.0075	Ugello bassa pressione - Nero / Low pressure nozzle - Black	40°	---
5.012.0281	Kit 5 ugelli foro 1.10 / Kit 5 nozzles hole 1.10	---	1.10
5.012.0282	Kit 5 ugelli foro 1.20 / Kit 5 nozzles hole 1.20	---	1.20

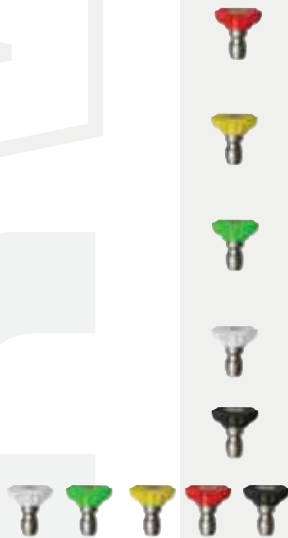
**Ugelli spurgatubi**

Pipe cleaning nozzles

Codice Code	Descrizione Description	Attacco Thread	Tipo Type
		A	
3.103.0035	Ugello spurgatubi con fori laterali Pipe cleaning nozzle with side holes	3/8" M	0.55
3.103.0105	Ugello spurgatubi tipo lungo Long head pipe cleaning nozzle	3/8" M	0.55
3.103.0106	Ugello spurgatubi stondato Rounded head pipe cleaning nozzle	3/8" M	0.55
3.103.0107	Ugello spurgatubi con fori laterali Pipe cleaning nozzle with side holes	3/8" F	0.55



Testine rotanti Rotating high pressure heads



**Attacco rapido 1/4" M
per raccordo girevole**
Quick coupling 1/4" M
for swivel coupling

Codice - Code :
4.607.0275



Codice Code	Descrizione Description	Attacco Thread	Foro Hole
		A	
3.749.0200	Testina con ugello rotante Head with rotating nozzle	1/4" F	040
3.749.0201	Testina con ugello rotante Head with rotating nozzle	1/4" F	045
3.749.0202	Testina con ugello rotante Head with rotating nozzle	1/4" F	050
3.749.0203	Testina con ugello rotante Head with rotating nozzle	1/4" F	055
3.749.0204	Testina con ugello rotante Head with rotating nozzle	1/4" F	060
3.749.0205	Testina con ugello rotante Head with rotating nozzle	1/4" F	065
3.749.0206	Testina con ugello rotante Head with rotating nozzle	1/4" F	070
3.749.0295	Ugello rotante Rotating nozzle	1/4" F	045
3.749.0466	Ugello rotante Rotating nozzle	1/4" F	055
3.749.0467	Ugello rotante Rotating nozzle	1/4" F	070

Testine sabbianti Sand blasting high pressure heads

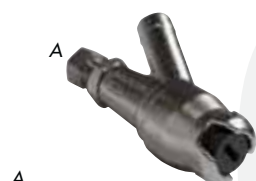

Codice Code	Descrizione Description	Attacco Thread	Pressione nominale Rated pressure			Portata Flow rate	Temp. max. Max. temp.	Tipo ugello Nozzle type
			bar	psi	MPa			
		A				l/min		
3.749.0207	Testina sabbiante TS 12 - uscita a lama Sand blasting head - blade type	1/4" F	500	7251	50	80	90°	(*) Vedi nota (*) See note
3.749.0208	Testina sabbiante TS 12 - uscita tonda Sand blasting head - round type	1/4" F	500	7251	50	80	90°	(*) Vedi nota (*) See note
3.749.0209	Testina sabbiante TS 12 - uscita prolungata Sand blasting head - prolonged type	1/4" F	500	7251	50	80	90°	(*) Vedi nota (*) See note
3.749.0210	Sonda regolabile L = 500 mm Prolonged adjustable probe L = 500 mm	Ø 21 mm	---	---	---	---	---	---
3.749.0382	Testina sabbiante Widia + sonda Sand blasting head Widia + probe	1/4" F	250	3625	25	40	90°	040
3.749.0383	Testina sabbiante Widia + sonda Sand blasting head Widia + probe	1/4" F	250	3625	25	40	90°	050
3.749.0384	Testina sabbiante Widia + sonda Sand blasting head Widia + probe	1/4" F	250	3625	25	40	90°	075

(*) Le testine sabbianti non sono comprensive di ugello. Abbinare sempre all'ordine l'ugello necessario:
3.749.0432 Ugello 15050 - 3.749.0433 Ugello 15045 - 3.749.0434 Ugello 15040

(*) Sand-blasting heads are not supplied with nozzles. Orders will be always placed with the nozzle required:
code 3.749.0432 15050 nozzle - code 3.749.0433 15045 nozzle - code 3.749.0434 15040 nozzle

Kit lancia sabbiante per idropultrici hobby*Sand blasting lance kit for domestic high pressure cleaners*

Codice Code	Descrizione Description	Attacco Thread	Pressione nominale Rated pressure			Portata Flow rate	Temp. max. Max. temp.	
			bar	psi	MPa		°C	°F
6.002.0177	Kit lancia sabbiante Sand blasting lance kit	Baionetta Bayonet Lavor	160	2320	16	11	40	104
3.749.0208	Kit lancia sabbiante Sand blasting lance kit	M22 Ø14	160	2320	16	11	90	194



A

Kit lancia sabbiante per idropultrici professionali*Sand blasting lance kit for domestic high pressure cleaners*

Codice Code	Descrizione Description	Attacco Thread	Pressione nominale Rated pressure			Portata Flow rate	Temp. max. Max. temp.		Fattore di portata Hole
			bar	psi	MPa		°C	°F	
		A	bar	psi	MPa	l/min	°C	°F	
6.608.0049	Kit lancia sabbiante Sand blasting lance kit	M22 Ø14	250	3625	25	11	140	284	040
6.608.0050	Kit lancia sabbiante Sand blasting lance kit	M22 Ø14	250	3625	25	15	140	284	050
6.608.0051	Kit lancia sabbiante Sand blasting lance kit	M22 Ø14	250	3625	25	21	140	284	070

**Sabbia calibrata per lance sabbianti***Calibrated sand for sand blasting lances*Codice - Code :
0.011.0001

6 pezzi da 5 kg

6 pieces of 5 kg each

Manometri

Manometers



Codice Code	Descrizione Description	Scala pressione Pressure range			Attacco Thread	Diametro Diameter
		bar	psi	Mpa		
3.107.0021	Manometro con attacco posteriore Manometer with rear coupling	0-6	0-87	0-0.6	1/8" M	40
3.107.0015	Manometro con attacco posteriore + staffa Manometer with rear coupling + bracket	0-10	0-145	0-1.0	1/8" M	40
3.107.0010	Manometro con attacco posteriore Manometer with rear coupling	0-16	0-232	0-1.6	1/8" M	40
3.107.0009	Manometro con attacco posteriore Manometer with rear coupling	0-160	0-2320	0-16	1/8" M	40
3.107.0006	Manometro con attacco posteriore Manometer with rear coupling	0-300	0-4351	0-30	1/8" M	40
3.107.0014	Manometro con attacco radiale Manometer with radial coupling	0-16	0-232	0-1.6	1/4" M	50
3.107.0002	Manometro con attacco posteriore Manometer with rear coupling	0-160	0-2320	0-16	1/4" M	50
3.107.0003	Manometro con attacco radiale Manometer with radial coupling	0-250	0-3625	0-25	1/4" M	50
3.107.0005	Manometro con attacco posteriore Manometer with rear coupling	0-250	0-3625	0-25	1/4" M	63
3.107.0004	Manometro con attacco posteriore + staffa Manometer with rear coupling + bracket	0-315	0-4568	0-31.5	1/4" M	50
3.107.0007	Manometro con attacco posteriore Manometer with rear coupling	0-315	0-4568	0-31.5	1/4" M	50
3.107.0019	Manometro con attacco posteriore + staffa Manometer with rear coupling + bracket	0-400	0-5801	0-40	1/4" M	50

Filtri per idropultrici hobby e professionali

Filters for domestic and professional high pressure cleaners



NEW

Codice Code	Descrizione Description	Entrata Inlet	Uscita Outlet	Pressione max. Max. pressure			Portata Flow rate		Potere filtrante Mesh
				bar	psi	MPa	l/m	GPM	µm
3.102.0011	Filtro ingresso acqua Water intake filter	G 3/4" F	G 3/4" M	10	145	1	30	7.93	80
3.749.0191	Filtro ingresso acqua ad Y - maglia metallica Y shaped water intake filter - metal mesh	G 3/4" F	G 3/4" F	10	145	1	30	7.93	80
3.100.0405	Filtro ingresso acqua Water intake filter	Innesto rapido tipo giardino Garden type quick coupling	G 3/4" F	10	145	1	30	7.93	80

Spazzole fisse e rotanti per idropulitrici hobby

Fixed and rotating brushes for domestic high pressure cleaners



Codice Code	Descrizione Description	Pressione Pressure			Portata Flow rate		Lunghezza Length	Attacco Coupling	Temperatura Temperature	
		bar	psi	MPa	l/m	GPM			mm	A
3.601.0091	Spazzola rotante Rotating brush	160	2320	16	15	3.96	500	Baionetta Bayonet Lavor	40	104
3.601.0033	Spazzola fissa Fixed brush	160	2320	16	15	3.96	500	Baionetta Bayonet Lavor	40	104



CON ADATTATORI
UNIVERSALI
WITH UNIVERSAL
ADAPTERS



Patio cleaners per idropulitrici hobby

Patio cleaners for domestic high pressure cleaners



Codice Code	Descrizione Description	Pressione Pressure			Portata Flow rate		Lunghezza Length	Attacco Coupling	Temperatura Temperature		Codice EAN EAN code
		bar	psi	MPa	l/m	GPM			mm	A	
6.008.0151	Patio cleaner Surfer con adattatori Patio cleaner Surfer with adapters	160	2320	16	15	3.96	1000	Lavor Karcher B&D M22	40	104	8013298011537
6.008.0201	Patio cleaner Slider con adattatori Patio cleaner Slider with adapters	130	1885	13	11	2.91	1000	Lavor Karcher B&D M22	40	104	8013298011926



Codice Code	Descrizione Description	Pressione Pressure			Portata Flow rate		Lunghezza Length	Attacco Coupling	Temperatura Temperature	
		bar	psi	MPa	l/m	GPM			mm	A
3.601.0097	Patio cleaner Eco con prolunga Patio cleaner Eco with extension	130	1885	13	11	2.91	1000	Baionetta Bayonet Lavor	40	104
3.601.0102	Patio cleaner Eco con prolunga Patio cleaner Eco with extension	160	2320	16	15	3.96	1000	Baionetta Bayonet Lavor	40	104



Codice Code	Descrizione Description	Pressione Pressure			Portata Flow rate		Lunghezza Length	Attacco Coupling	Temperatura Temperature	
		bar	psi	MPa	l/m	GPM			mm	A
6.010.0018	Kit spazzola Triplex Brush Triplex kit	160	2320	16	15	3.96	900	Baionetta Bayonet Lavor	40	104

Spazzole fisse e rotanti per idropultrici professionali

Fixed and rotating brushes for professional high pressure cleaners

Codice Code	Descrizione Description	Pressione Pressure			Portata Flow rate		Lunghezza Length	Attacco Coupling	Temperatura Temperature	
		bar	psi	MPa	l/m	GPM			mm	A
6.602.0035	Spazzola fissa con prolunga Fixed brush with extension pipe	250	3625	25	40	10.5	700	M22 Ø14	90	194
6.602.0036	Spazzola rotante con prolunga Rotating brush with extension pipe	250	3625	25	40	10.5	700	M22 Ø14	90	194
6.603.0004	Idrospazzola rotante con snodo Rotating wash brush	150	2175	15	15	3.96	700	M22 Ø14	40	104



Lance lavapavimenti per idropultrici professionali (senza ugelli)*

Floor cleaning lances for professional high pressure cleaners (without nozzles)*

Codice Code	Descrizione Description	Pressione Pressure			Portata Flow rate		Lunghezza Length	Attacco Coupling	Temperatura Temperature	
		bar	psi	MPa	l/m	GPM			mm	A
6.602.0020	Lancia lavapavimenti inox con pistola Stainless steel floor cleaning lance with gun	280	4061	28	20	5.29	1300	3/8" M	160	320
6.602.0052	Lancia lavapavimenti inox con ruote Stainless steel floor cleaning lance with wheels	250	3625	25	20	5.29	500	1/4" F	160	320



NEW

Patio cleaners professionali completi di tubo e pistola (senza ugelli)*

Professional patio cleaners complete with hose and gun (without nozzles)*

Codice Code	Descrizione Description	Pressione Pressure			Portata Flow rate		Lunghezza Length	Attacco Coupling	Temperatura Temperature	
		bar	psi	MPa	l/m	GPM			mm	A
3.749.0188	Lancia lavapavimenti rotante inox Stainless steel rotating floor cleaning lance	280	4061	28	40	10.5	1300	3/8" M	80	176

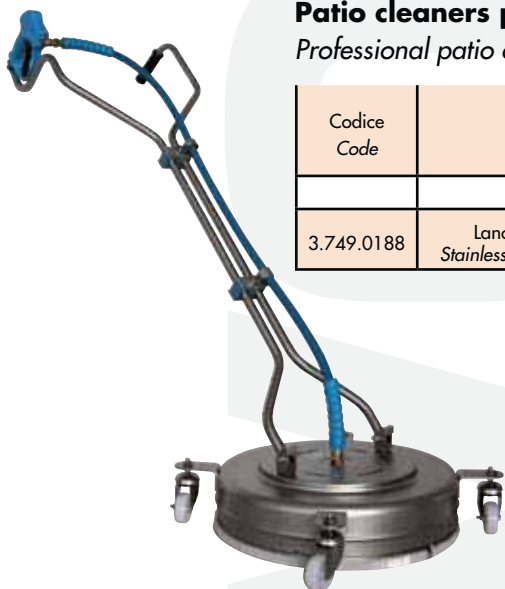

NEW

(*) Per gli ugelli vedere pagina 35
(*) For nozzles see page 35

Avvolgitubo automatici e manuali

Automatic and manual hose reels



Codice Code	Descrizione Description	Pressione Pressure			Temperatura Temperature		Entrata Inlet	Uscita Outlet	Lunghezza tubo Hose length	Diametro tubo Hose diameter
		bar	psi	MPa	°C	°F				
3.749.0481	Avvolgitubo automatico in metallo verniciato Varnished steel automatic hose reel	250	3625	25	140	284	3/8" M	3/8" F	-	-
3.749.0482	Avvolgitubo automatico in metallo verniciato - con tubo Varnished steel automatic hose reel with hose	250	3625	25	140	284	3/8" M	3/8" F	20	5/16"
Su richiesta On request	Avvolgitubo automatico inox con tubo Stainless steel automatic hose reel with hose	250	3625	25	140	284	3/8" M	3/8" F	20	5/16"
6.608.0022	Avvolgitubo da parete con staffe senza tubo (capacità 20 m tubo 3/8") Wall mount hose reel with brackets without hose (capability 20 m hose 3/8")	---	---	---	---	---	3/8" M	3/8" M	---	---



Lancia schiuma con serbatoio per idropultrici hobby

Foam injector lance with plastic bottle for domestic high pressure cleaners

Codice Code	Descrizione Description	Pressione Pressure			Portata Flow rate		Temperatura Temperature		Attacco Coupling	Capacità serbatoio Bottle capacity
		bar	psi	MPa	l/m	GPM	°C	°F		
6.010.0036	Lancia schiuma in bassa pressione con serbatoio Foam lance with plastic bottle	15	217	1.5	15	3.96	40	104	Baionetta Bayonet Lavor	2

Pagina
Page



Lancia schiuma con serbatoio per idropultrici hobby

Foam injector lance with plastic bottle for domestic high pressure cleaners

Codice Code	Descrizione Description	Pressione Pressure			Portata Flow rate		Temperatura Temperature		Attacco Coupling	Capacità serbatoio Bottle capacity
		bar	psi	MPa	l/m	GPM	°C	°F		
6.002.0259	Lancia schiuma in bassa pressione con serbatoio Foam lance with plastic bottle	15	217	1.5	15	3.96	40	104	Rapido per lancia Lavor Quick for Lavor lance	0.5
6.002.0162	Lancia schiuma in bassa pressione con serbatoio Foam lance with plastic bottle	15	217	1.5	15	3.96	40	104	Baionetta Bayonet Lavor	0.5



Lancia schiuma per idropultrici professionali

Foam injector lances for professional high pressure cleaners



Codice Code	Descrizione Description	Pressione Pressure			Portata Flow rate		Temperatura Temperature		Attacco Coupling
		bar	psi	MPa	l/m	GPM	°C	°F	
6.602.0003	Lancia schiuma indiretto Indirect foam lance	250	3625	25	40	10.6	90	194	M22 Ø14

NEW



Codice Code	Descrizione Description	Pressione Pressure			Portata Flow rate		Temperatura Temperature		Attacco Coupling	Capacità serbatoio Bottle capacity
		bar	psi	MPa	l/m	GPM	°C	°F		
6.602.0051	Lancia schiuma con regolatore e serbatoio Foam lance with regulator and plastic bottle	180	2610	18	21	5.55	60	140	Rapido a sfera Quick ball coupling	1
6.602.0053	Lancia schiuma con regolatore e serbatoio Foam lance with regulator and plastic bottle	180	2610	18	21	5.55	60	140	M22 Ø14	1

NEW

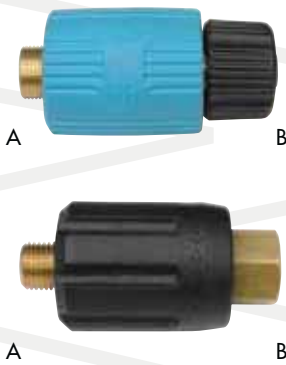

Codice Code	Descrizione Description	Pressione Pressure			Portata Flow rate		Temperatura Temperature		Attacco Coupling
		bar	psi	MPa	l/m	GPM	°C	°F	
6.602.0054	Lancia schiuma con regolatore Foam lance with regulator	180	2610	18	21	5.55	60	140	Rapido a sfera Quick ball coupling
6.602.0055	Lancia schiuma con regolatore Foam lance with regulator	180	2610	18	21	5.55	60	140	M22 Ø14

NEW**Regolatori di portata per idropulitrici professionali***Pressure adjusting coupling for professional high pressure cleaners*

Codice Code	Descrizione Description	Entrata Inlet		Pressione max. Max. pressure			Portata Flow rate		Temperatura Temperature	
		A	B	bar	psi	MPa	l/m	GPM	°C	°F
3.703.0023	Raccordo regolatore di portata <i>Water flow adjuster coupling</i>	M22Ø14	M22F Ø14	280	4061	28	30	7.93	160	320
3.703.0024	Raccordo regolatore di portata <i>Water flow adjuster coupling</i>	1/4" M	M22F Ø14	280	4061	28	30	7.93	160	320
3.703.0009	Raccordo regolatore di portata <i>Water flow adjuster coupling</i>	1/4" M	1/4" F	280	4061	28	30	7.93	160	320

Accessori generici per idropulitrici ad alta alta pressione

Generic accessories for high pressure cleaners

Testina motorizzata*Motorized head*

- Testina motorizzata in acciaio inox per la pulizia di cisterne, contenitori e serbatoi
Stainless steel motorized head for case and tank cleaning
- Copertura orbitale completa degli interni
Complete orbital internal coverage
- Completa di ugelli e trasformatore
Complete with nozzles and converter

Testina motorizzata - Motorized head	
Codice - Code	3.749.0196
Pressione di esercizio - Operating pressure	220 bar - 3190 psi
Pressione consentita - Allowed pressure	250 bar - 3625 psi
Portata di esercizio - Operating delivery rate	1,200 l/h - 5.56 GPM
Temperatura nominale - Nominal temperature	90 °C - 194 °F
Ingombro diametro min. - Minimum diameter	Ø 40 mm
Tipo di ugelli - Nozzle type	2 x M4

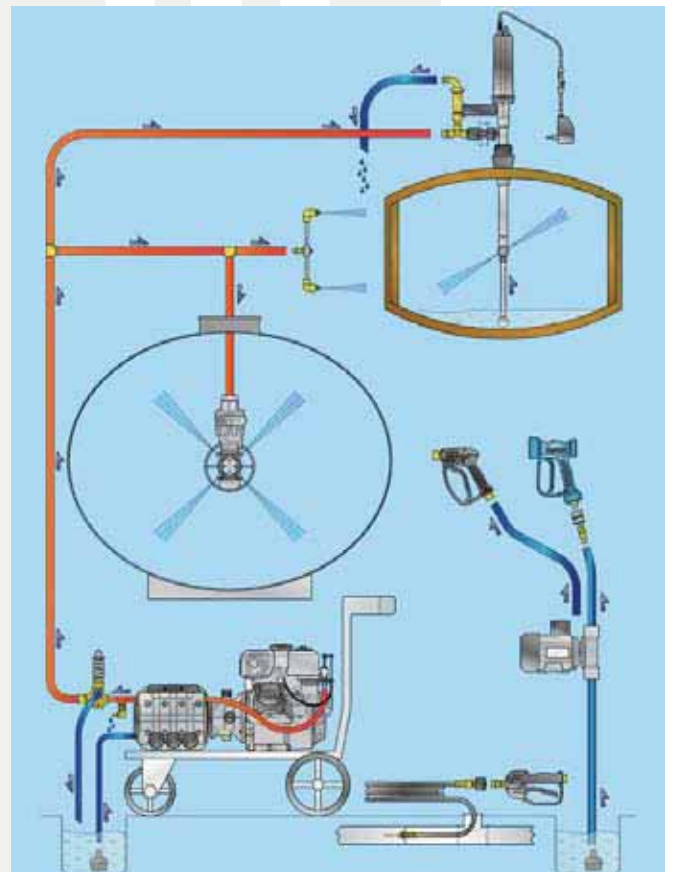



Vaschetta per idropultrici professionali

Water tank for professional high pressure cleaners

Codice Code	Descrizione Description	Foro ingresso Inlet hole	Foro uscita Outlet hole	Capacità Capacity
		(A) Ø mm	(B) Ø mm	lt
4.608.0230	Vaschetta Water tank	3/4"	17	5



Coperchio per vaschetta per idropultrici professionali

Cover for water tank for professional high pressure cleaners

Codice - Code
4.608.0231



Vaschetta completa con coperchio, rubinetto raccordi e tubi

Water tank complete with cover, float valve, couplings and hoses

Codice - Code
6.605.0023



Rubinetto a galleggiante per vaschetta

Float valve for water tank

Codice Code	Descrizione Description	Attacco Thread
		A
3.749.0458	Rubinetto a galleggiante Float valve	3/4" M

NEW



Rubinetto a galleggiante per vaschetta (soft ON/OFF)

Float valve for water tank (soft ON/OFF)

Codice Code	Descrizione Description	Attacco Thread
		A
3.749.0493	Rubinetto a galleggiante Float valve	3/4" M

NEW**Anticalcare meccanico completo di raccordi***Mechanical antiscalant device with joints*

Codice - Code

5.609.0119**NEW****Serbatoio per dispositivo anticalcare - 1 l***Tank for antiscalant device - 1 l*

Codice - Code

3.754.0024**NEW****Supporto per serbatoio per dispositivo anticalcare***Tank support for antiscalant device*

Codice - Code

5.613.0142

Kit di accessori per idropultrici hobby

Accessories kit for domestic high pressure cleaners

Garden set

Codice - Code
6.008.0200



Codice EAN-EAN code:8013298011889



Outdoor set

Codice - Code
6.008.0199



Codice EAN-EAN code:8013298011629



Car Wash set

Codice - Code
6.008.0177



Codice EAN-EAN code: 8013298011506



NEW

Kit manutenzione e antigelo per idropultrici hobby e professionali

Maintenance and antifreeze kit for domestic and professional high pressure cleaners

Versione Lavor
Lavor version
Codice - Code
6.005.0363

-40°C



- (IT)**
- Connettere il tubo trasparente al raccordo di uscita della idropultrice.
 - Riempire il tubo trasparente di antigelo.
 - Montare il raccordo di entrata.
 - Far funzionare l'idropultrice per massimo 15 secondi.

- (EN)**
- Connect the transparent hose to the outlet connection of the high pressure washer.
 - Fill the transparent hose with anti-freeze.
 - Connect the other hose's end to the inlet connection of the high pressure washer.
 - Turn the high pressure washer on, for max 15 seconds.

Codice Code	Descrizione Description	Contenuto bottiglia Bottle capacity	Attacco Coupling	Attacco Coupling	Adatto per: Suitable for:	Attacco Coupling
		ml	A	B		
6.005.0359	Kit manutenzione e antigelo <i>Maintenance and antifreeze kit</i>	100	Innesto rapido tipo giardino <i>Garden type quick coupling</i>	K1 - K7 Quick	Karcher nuovo attacco rapido <i>new quick coupling K1 - K7</i>	
6.005.0360	Kit manutenzione e antigelo <i>Maintenance and antifreeze kit</i>	100	Innesto rapido tipo giardino <i>Garden type quick coupling</i>	M22 Ø14 cilindrico <i>cylindrical</i>	Karcher attacco cilindrico M22 Ø14 <i>cylindrical coupling K1 - K7</i>	
6.005.0362	Kit manutenzione e antigelo <i>Maintenance and antifreeze kit</i>	100	Innesto rapido tipo giardino <i>Garden type quick coupling</i>	M22 corto <i>M22 short</i>	Karcher M22 corto <i>M22 short</i>	
6.005.0361	Kit manutenzione e antigelo <i>Maintenance and antifreeze kit</i>	100	Innesto rapido tipo giardino <i>Garden type quick coupling</i>	M22 Ø14	Black & Decker Annovi Reverberi Karcher	
6.005.0363	Kit manutenzione e antigelo <i>Maintenance and antifreeze kit</i>	100	Innesto rapido tipo giardino <i>Garden type quick coupling</i>	M22 Ø15 cilindrico <i>cylindrical</i>	LAVOR	

Spray lubrificante e antigelo per manutenzione pompa High pressure cleaner pump saver

NEW



**Ideale anche per lo sbloccaggio
valvole delle idropultrici con
vaschetta**
**Ideal also for unlocking valves
of high pressure cleaners with
water tank**

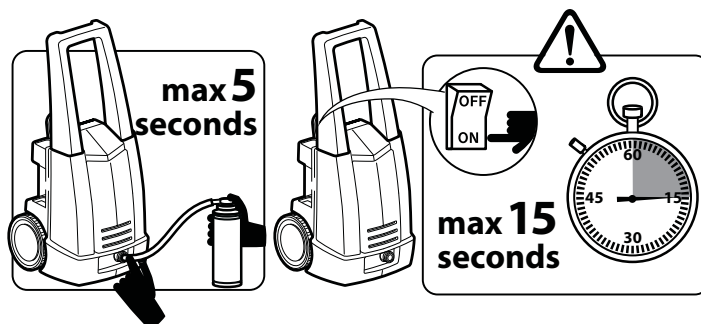

- (IT) • Connettere il tubo trasparente al raccordo di **entrata** della idropulitrice.
- Spruzzare il prodotto per 5 secondi.
- Far funzionare l'idropulitrice per massimo 15 secondi.
- (FR) • Branchez le tuyau transparent à votre connexion **d'entrée**.
- Pulvériser le liquide.
- Mettre en marche votre nettoyeur à haute pression pour 15 max secondes.
- (EN) • Connect the transparent hose to the **inlet** connection of the high pressure washer.
- Spray the liquid for 5 seconds.
- Turn the high pressure washer on, for max 15 seconds.
- (DE) • Verbinden Si den transparenten Schlauch zum **Ausflussanschluss** des Hochdruckreinigers **Eintrag**.
- Sprühen Si den Flüssigkeit;
- Schalten Sie den Hochdruckreiniger für max. 15 Sekunden ein.

Codice Code	Descrizione Description	Contenuto bottiglia Bottle capacity	Attacco Coupling	Adatto per: Suitable for:
		ml	A	
0.010.0040	Spray lubrificante e antigelo per manutenzione pompa <i>Lubrication and antifreeze kit for pump maintenance</i>	150	Adatto per ingresso da 3/4", 1/2" e M22 <i>Suitable for 3/4", 1/2" and M22 inlet</i>	Tutti i marchi <i>All brands</i>

Pompe ad alta pressione complete
High pressure pumps

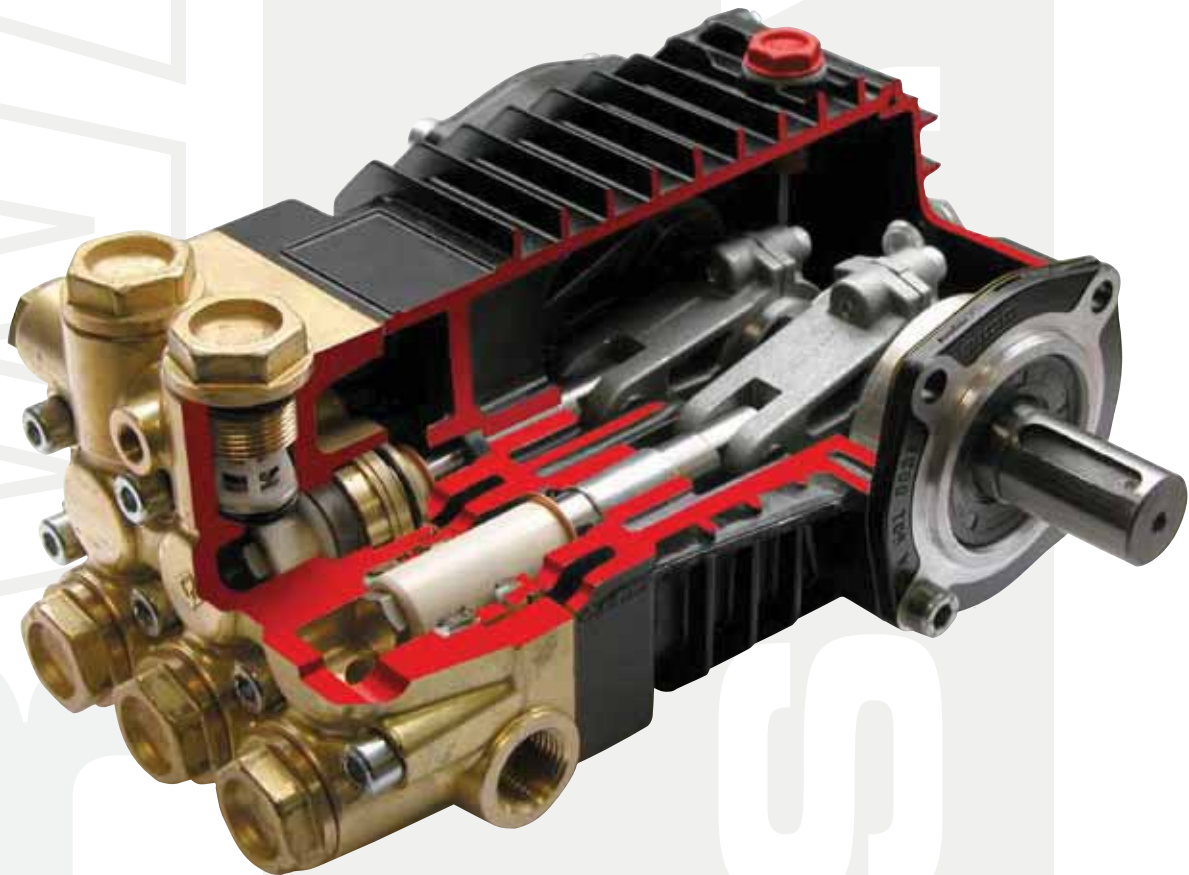

- Studio approfondito e comparativo su ogni particolare costruttivo:
- Pistoni in ceramica a basso grado d'usura
 - Bielle a basso coefficiente d'attrito, realizzate in lega d'alluminio; doppio corpo per favorirne lo smontaggio
 - Minimo carico sui cuscinetti conici (tramite calibrazione elettronica della rotazione dell'albero)
 - Bassissime temperature d'esercizio

An in-depth and comparative study on each structural element:

- *Low wear and tear ceramic pistons*
- *Low friction connecting rod, built in aluminium alloy; double body for easy disassembly*
- *Minimum charge on the cone-shaped bearings (through electronic calibration of the drive shaft rotation)*
- *Very low operating temperature.*

Pompe ad alta pressione
High-pressure pumps

Serie CL3

Cleaning

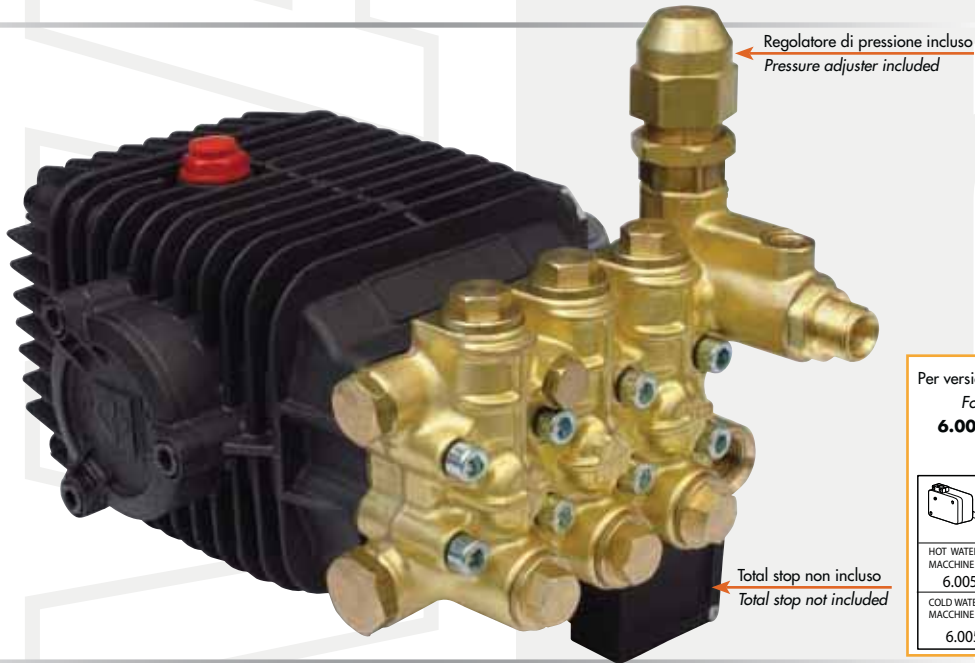

Per versione con Total Stop aggiungere:
For Total Stop version add:
6.005.0288 - Kit Total Stop

	230-240 V		24 V
HOT WATER MACHINES MACCHINE ACQUA CALDA	6.005.0293	HOT WATER MACHINES MACCHINE ACQUA CALDA	
COLD WATER MACHINES MACCHINE ACQUA FREDDA	6.005.0294	COLD WATER MACHINES MACCHINE ACQUA FREDDA	5.609.0246

Modello Model	Ver. albero DX Right shaft ver.	Ver. albero SX Left shaft ver.	Giri al min. RPM		Pressione massima Max. pressure			Portata Flow rate		Potenza assorbita Requested power			Peso Weight				
					bar	psi	MPa	l/m	GPM	HP	kW	kg	lbs				
CL 34-15 9-200	5.700.0018	5.700.0019	1450	1750	200	2900	20	9	11	2.4	2.9	4,9	6	3,6	4,4	6,6	14,5
CL 34-15 11-200	5.700.0020	5.700.0021	1450	1750	200	2900	20	11	13	2.9	3.5	6	6,5	4,4	4,8	6,6	14,5
CL 34-18 15-200	5.701.0006	5.701.0007	1450	1750	200	2900	20	15	18	4	4.7	7,5	9,2	5,5	6,9	7	15,4

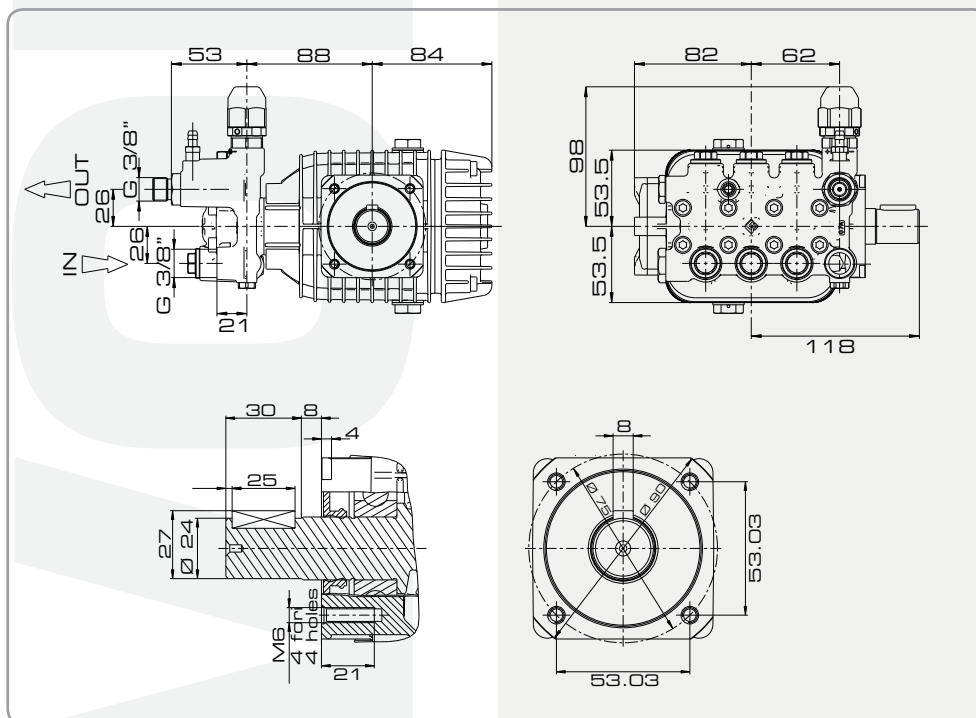

Pompe ad alta pressione
High-pressure pumps

Serie CL5



Cleaning

Modello Model	Ver. albero DX Right shaft ver.	Ver. albero SX Left shaft ver.	Giri al min. RPM		Pressione massima Max. pressure			Portata Flow rate				Potenza assorbita Requested power				Peso Weight	
					bar	psi	MPa	l/m		GPM		HP		kW		kg	lbs
	Code	Code															
CL 54-20 11-200	5.699.0024	5.699.0025	1450	1750	200	2900	20	11	13	2.9	3.5	6	6,5	4,4	4,8	9,8	21,6
CL 54-20 15-200	5.699.0005	5.699.0009	1450	1750	200	2900	20	15	18	4	4.7	7,5	9,2	5,5	6,9	9,8	21,6
CL 54-20 21-200	5.699.0006	5.699.0010	1450	1750	200	2900	20	21	25	5.5	6.6	10,5	12,8	7,7	9,5	9,8	21,6

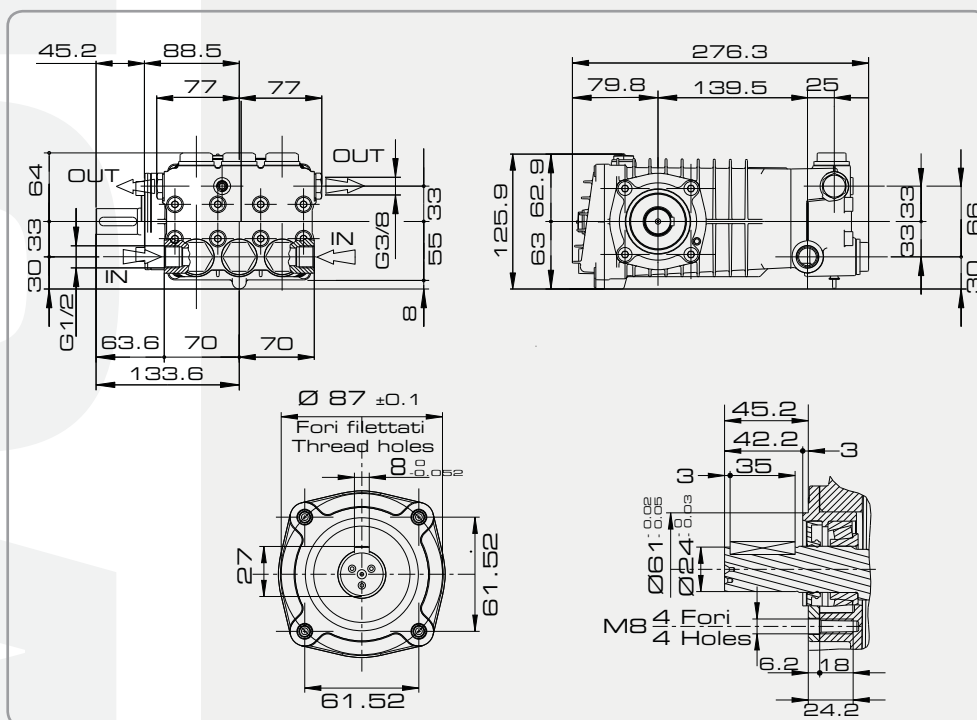

Pompe ad alta pressione
High-pressure pumps

Serie CW5

Car Wash



Modello Model	Ver. albero DX Right shaft ver.	Ver. albero SX Left shaft ver.	Press. max. Max. press.			Giri al min. RPM		Portata Flow rate				Potenza assorbita Requested power				Peso Weight	
	Code	Code	bar	psi	Mpa			l/m	GPM	HP	kW	kg	lbs				
CW 54-20 11-200	5.699.0037	5.699.0039	200	2900	20	1450	1750	11	13	2,9	3,5	6	6,5	4,4	4,8	9,8	21,6
CW 54-20 15-200	5.699.0036	5.699.0038	200	2900	20	1450	1750	15	18	4	4,7	7,5	9,2	5,5	6,9	9,8	21,6
CW 54-20 21-200	5.699.0040	5.699.0041	200	2900	20	1450	1750	21	25	5,5	6,6	10,5	12,8	7,7	9,5	9,8	21,6

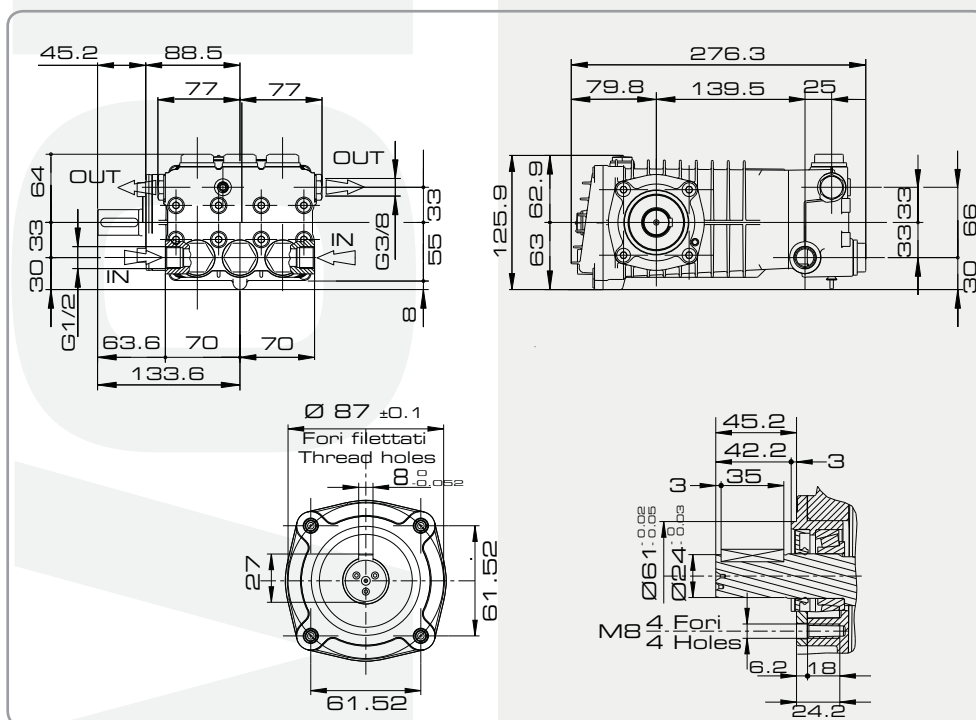

Pompe ad alta pressione per alte temperature
High-pressure pumps for hot water

Serie HW3



Regolatore di pressione incluso
Pressure adjuster included

Total stop non incluso
Total stop not included

Per versione con Total Stop aggiungere:
For Total Stop version add:
6.005.0288 - Kit Total Stop

230-240V		24V	
HOT WATER MACHINES MACCHINE ACQUA CALDA 6.005.0293		HOT WATER MACHINES MACCHINE ACQUA CALDA COLD WATER MACHINES MACCHINE ACQUA FREDDA 6.005.0294	
		5.609.0246	

Pompe per alte temperature
Hot Water 85° C

Modello Model	Ver. albero DX Right shaft ver.	Ver. albero SX Left shaft ver.	Giri al min. RPM			Pressione massima Max. pressure			Portata Flow rate				Potenza assorbita Requested power				Peso Weight	
			Code	Code		bar	psi	MPa	l/m	GPM	HP	kW	kg	lbs				
HW 34-15 9-200			1450	1750	200	2900	20	9	11	2.4	2.9	4,9	6	3,6	4,4	6,6	14,5	
HW 34-15 11-200	su richiesta on request	su richiesta on request	1450	1750	200	2900	20	11	13	2.9	3.5	6	6,5	4,4	4,8	6,6	14,5	
HW 34-18 15-200			1450	1750	200	2900	20	15	18	4	4.7	7,5	9,2	5,5	6,9	7	15,4	

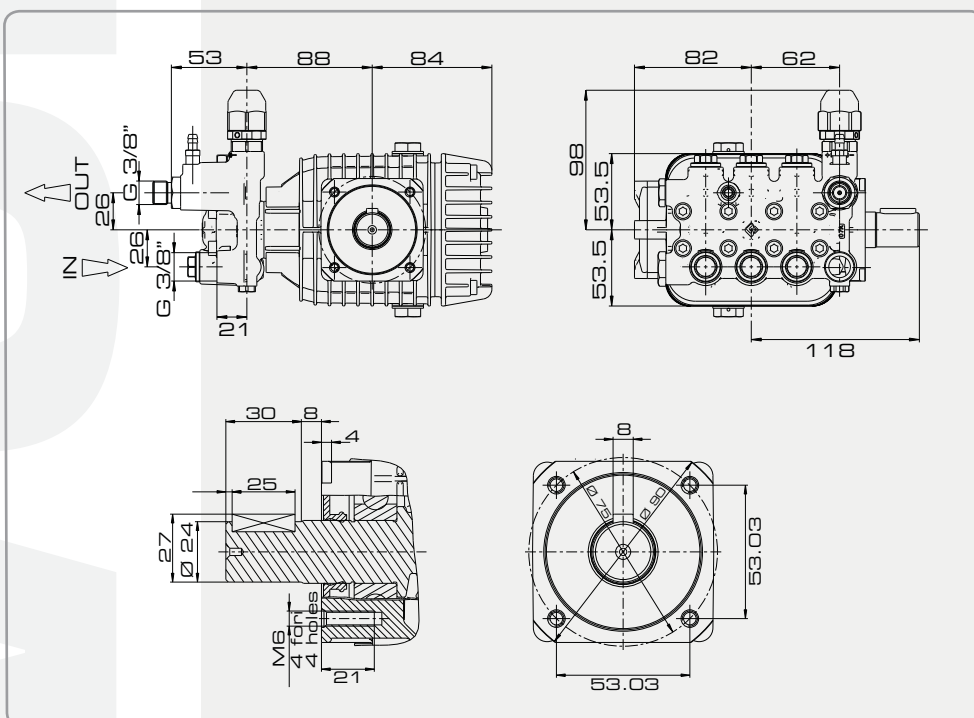

Pompe ad alta pressione per alte temperature
High-pressure pumps for hot water

Serie HW5

Pompe per alte temperature
Hot Water 85° C



Modello Model	Ver. albero DX Right shaft ver.	Ver. albero SX Left shaft ver.	Press. max. Max. press.			Giri al min. RPM		Portata Flow rate				Potenza assorbita Requested power				Peso Weight	
	Code	Code	bar	psi	Mpa			l/m	GPM	HP	kW	kg	lbs				
HW 54-20 11-200	5.699.0037	5.699.0039	200	2900	20	1450	1750	11	13	2.9	3.5	6	6,5	4,4	4,8	9,8	21,6
HW 54-20 15-200	5.699.0036	5.699.0038	200	2900	20	1450	1750	15	18	4	4.7	7,5	9,2	5,5	6,9	9,8	21,6
HW 54-20 21-200	5.699.0040	5.699.0041	200	2900	20	1450	1750	21	25	5.5	6.6	10,5	12,8	7,7	9,5	9,8	21,6

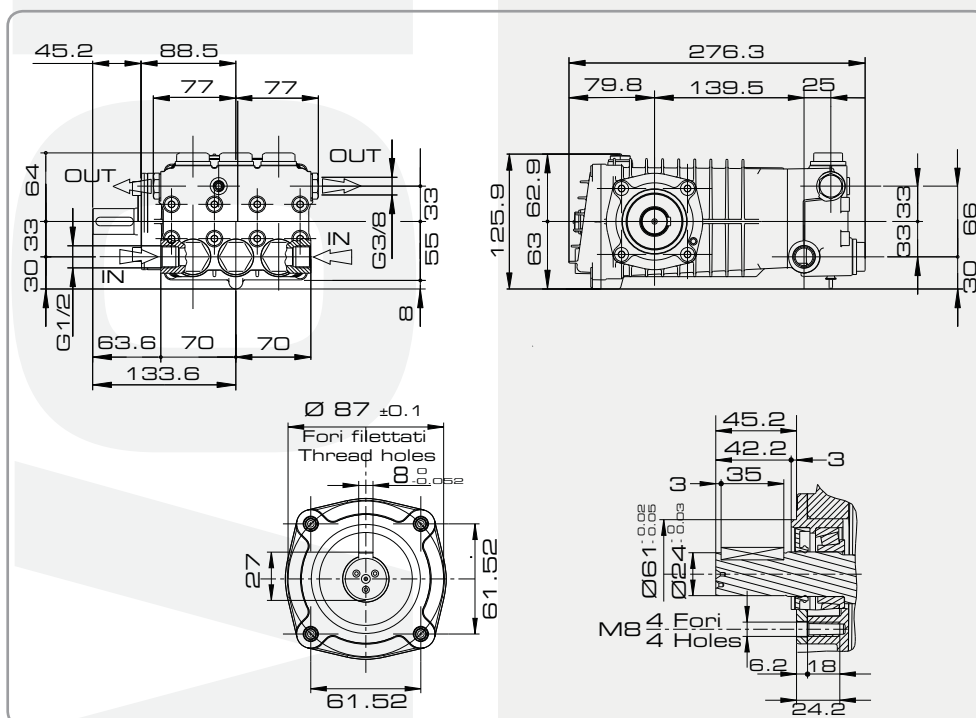

Pompe ad alta pressione in acciaio inox
Stainless steel high-pressure pumps

Serie SS3



Stainless Steel

Modello Model	Ver. albero DX Right shaft ver.	Ver. albero SX Left shaft ver.	Giri al min. RPM		Pressione massima Max. pressure			Portata Flow rate				Potenza assorbita Requested power				Peso Weight	
					bar	psi	MPa	l/m		GPM		HP		kW		kg	lbs
	Code	Code															
SS 34-15 9-200	5.700.0022	5.700.0023	1450	1750	200	2900	20	9	11	2.4	2.9	4,9	6	3,6	4,4	9,8	21,6
SS 34-15 11-200	5.700.0024	5.700.0025	1450	1750	200	2900	20	11	13	2.9	3.5	6	6,5	4,4	4,8	9,8	21,6

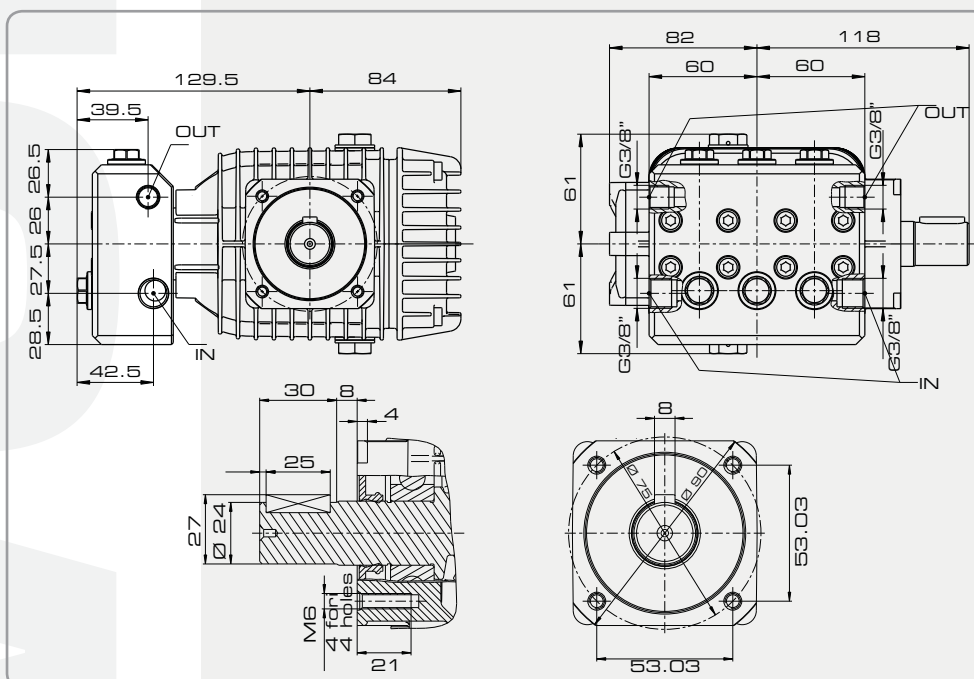

Pompe ad alta pressione in acciaio inox
Stainless steel high-pressure pumps

Serie SS5

Stainless Steel



Modello Model	Ver. albero DX Right shaft ver.	Ver. albero SX Left shaft ver.	Giri al min. RPM		Pressione massima Max. pressure			Portata Flow rate		Potenza assorbita Requested power				Peso Weight			
	Code	Code			bar	psi	MPa	l/m	GPM	HP	kW		kg	lbs			
SS 54-20 11-200	5.699.0043	5.699.0044	1450	1750	200	2900	20	11	13	2.9	3.5	6	6,5	4,4	4,8	9,8	21,6
SS 54-20 15-200	5.699.0045	5.699.0046	1450	1750	200	2900	20	15	18	4	4.7	7,5	9,2	5,5	6,9	9,8	21,6
SS 54-20 21-200	5.699.0047	5.699.0048	1450	1750	200	2900	20	21	25	5.5	6.6	10,5	12,8	7,7	9,5	9,8	21,6

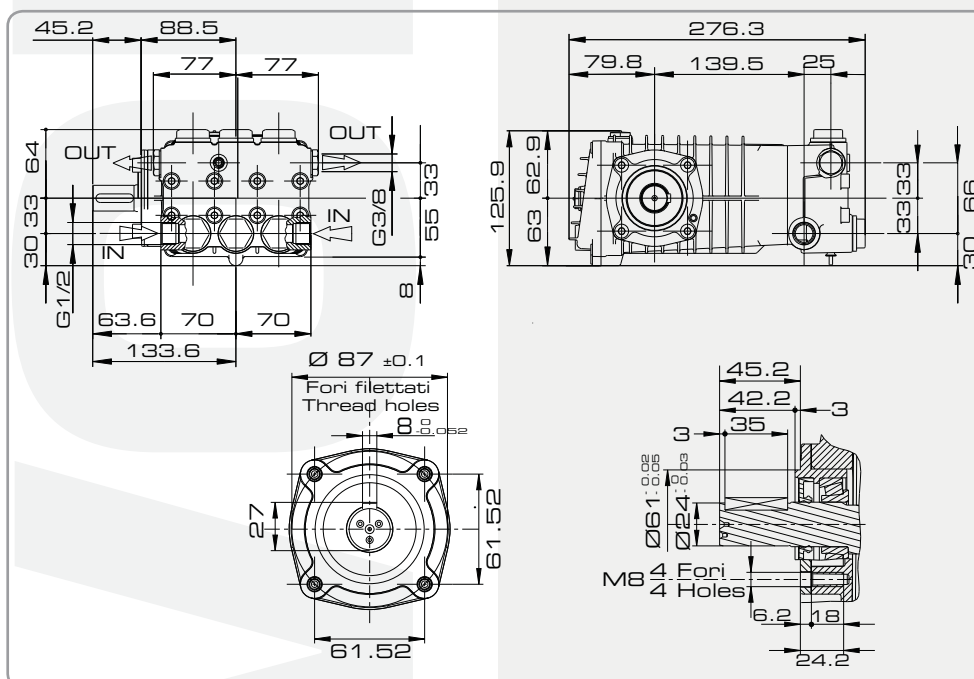

Pompe ad alta pressione per motori a scoppio
Gasoline motor-pumps units

TPBV



Pompe per motori a scoppio
Gasoline motor-pump units

Modello Model	Codice Code	Giri al min. RPM	Pressione massima Max. pressure			Portata Flow rate		Potenza assorbita Requested power		Peso Weight	
			bar	psi	MPa	l/m	GPM	HP	kW	kg	lbs
TPBV 27-20	8.601.A061	3400	180	2610	18	7,7	2	5,5	4	2,15	4,74

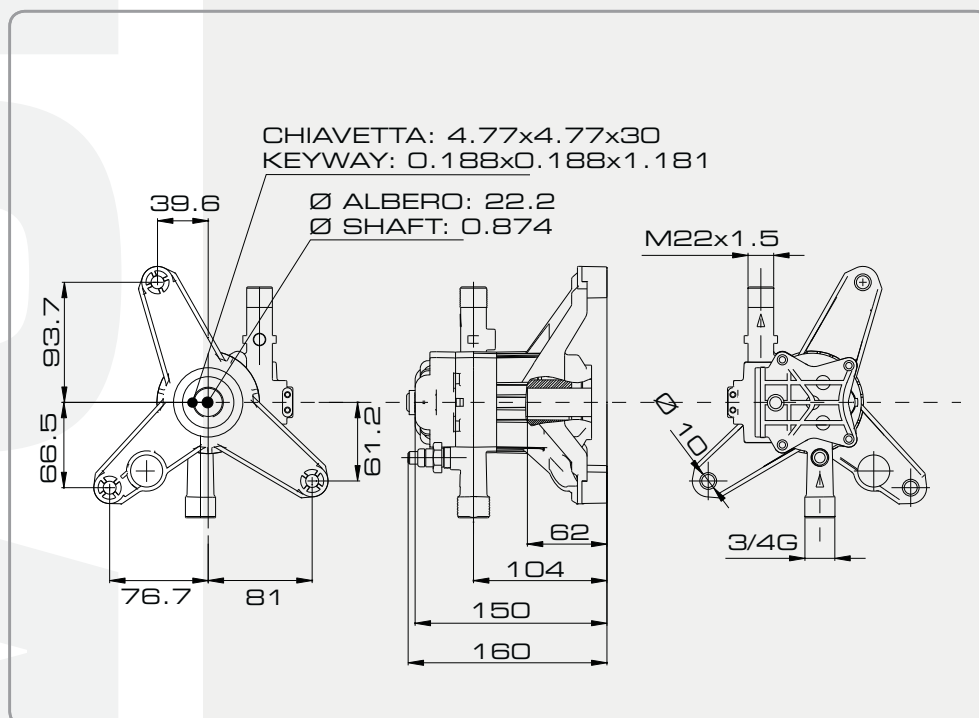

Pompe ad alta pressione per motori a scoppio
Gasoline motor-pumps units

TPAV

Pompe per motori a scoppio
Gasoline motor-pump units



Modello Model	Codice Code	Giri al min. RPM	Pressione massima Max. pressure			Portata Flow rate		Potenza assorbita Requested power		Peso Weight	
			bar	psi	MPa	l/m	GPM	HP	kW	kg	lbs
TPAV 21-20	8.601.A060	3400	145	2100	14,5	7,7	2	4,5	3,3	1,80	3,96

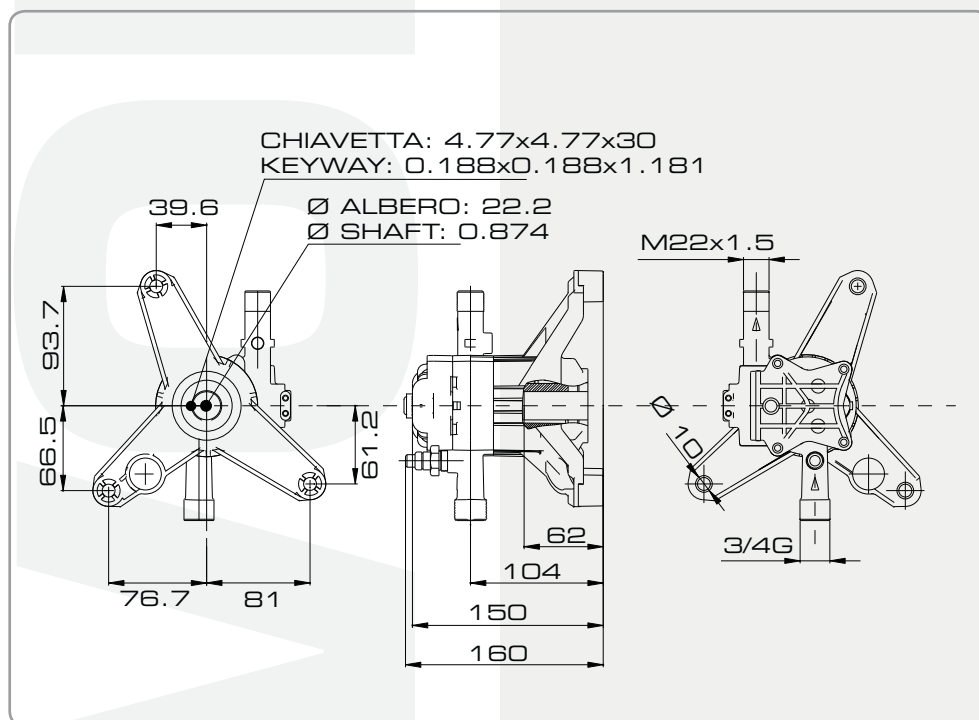

Pompe ad alta pressione per motori a scoppio
Gasoline motor-pumps units

TPBV3

NEW



Pompe per motori a scoppio
Gasoline motor-pump units

Modello Model	Codice Code	Giri al min. RPM	Pressione massima Max. pressure			Portata Flow rate		Potenza assorbita Requested power		Peso Weight	
			bar	psi	MPa	l/m	GPM	HP	kW	kg	lbs
TPBV3	8.601.A065	3400	200	2900	20	9	2,4	6,5	4,8	2,60	5,73

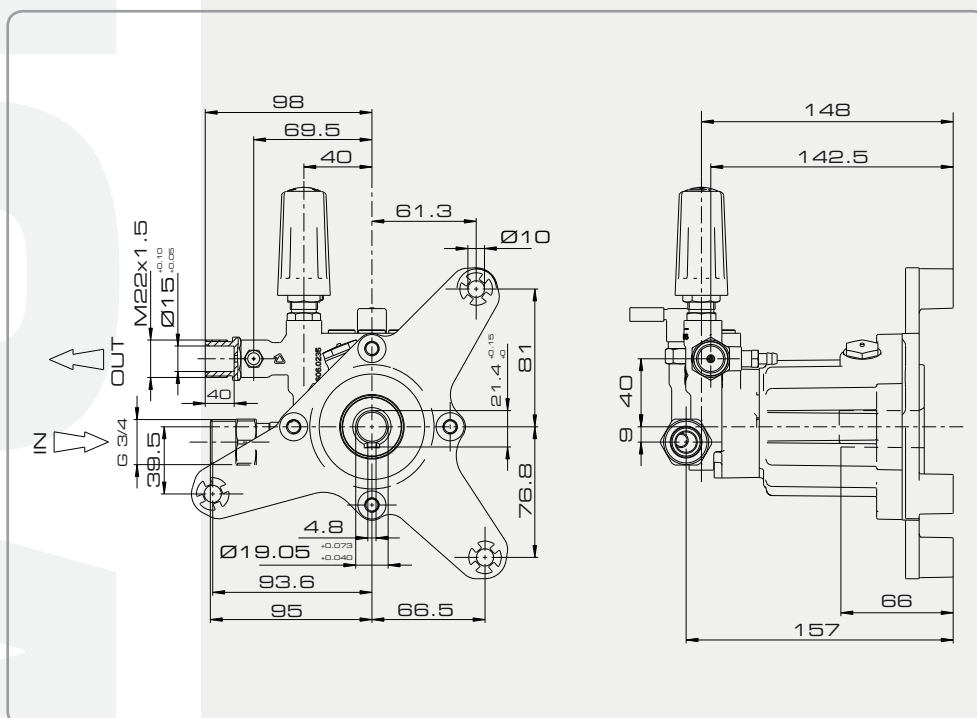

Pompe ad alta pressione per motori a scoppio
Gasoline motor-pumps units

TPBH3

Pompe per motori a scoppio
Gasoline motor-pump units

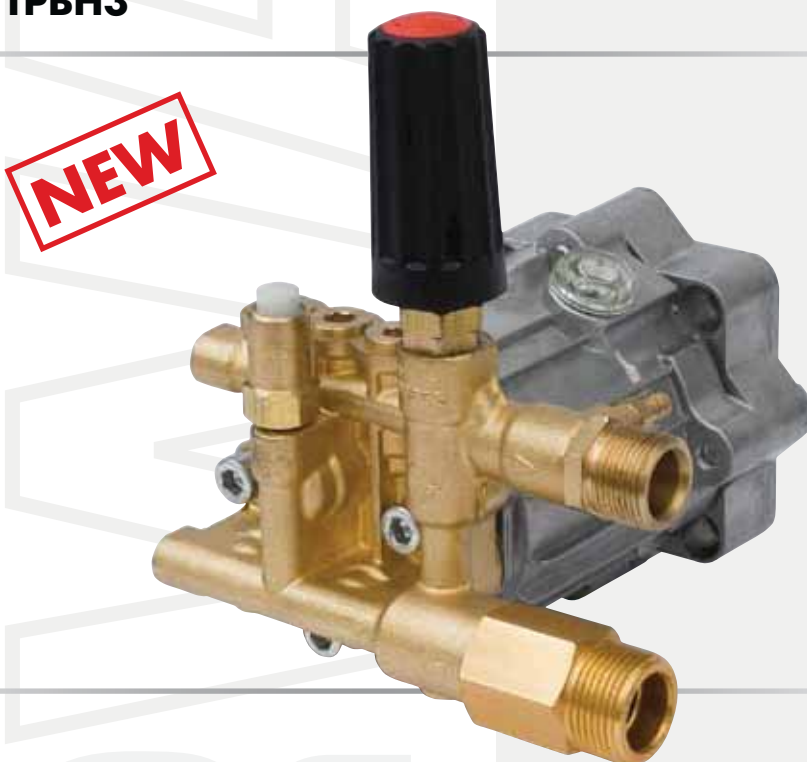

Modello Model	Codice Code	Giri al min. RPM	Pressione massima Max. pressure			Portata Flow rate		Potenza assorbita Requested power		Peso Weight	
			bar	psi	MPa	l/m	GPM	HP	kW	kg	lbs
TPBH3 30-24	8.601.A062	3400	200	2900	20	9	2,4	6,5	4,8	2,40	5,29

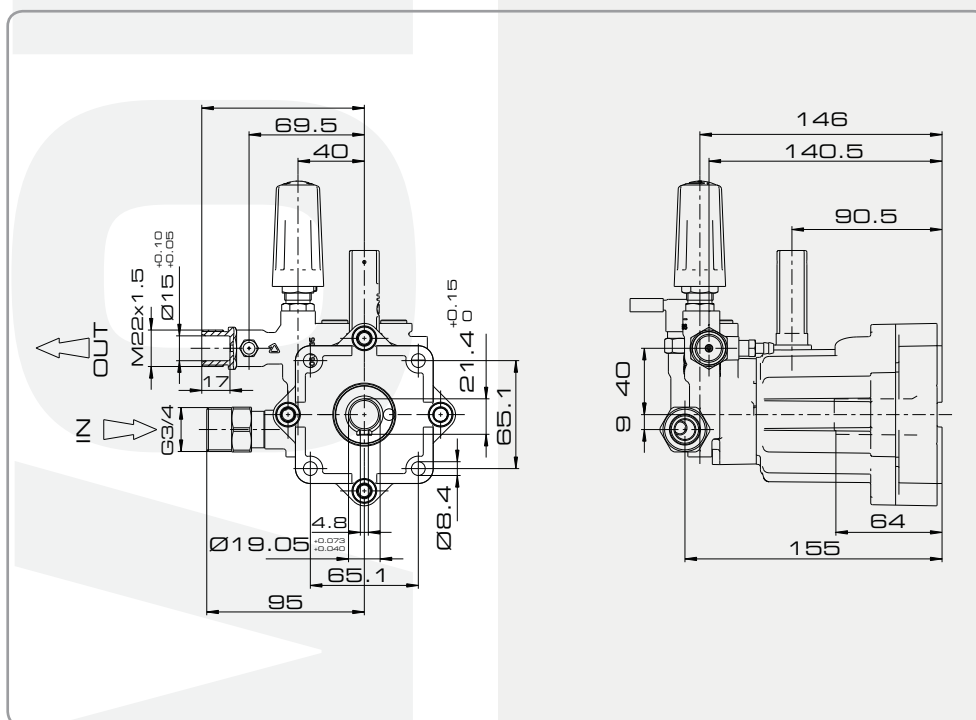

Pompe ad alta pressione per motori a scoppio
Gasoline motor-pumps units

TPAH3

NEW

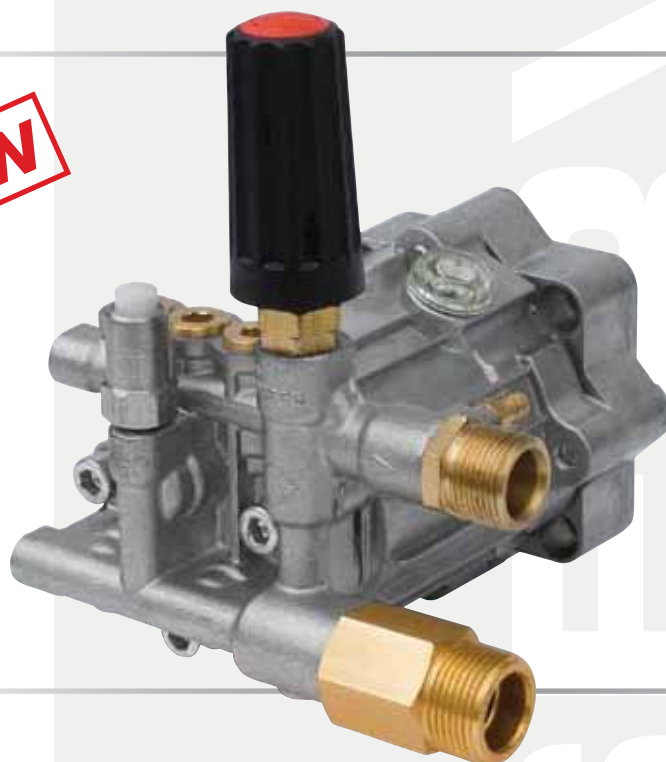

Pompe per motori a scoppio
Gasoline motor-pump units

Modello Model	Codice Code	Giri al min. RPM	Pressione massima Max. pressure			Portata Flow rate		Potenza assorbita Requested power		Peso Weight	
			bar	psi	MPa	l/m	GPM	HP	kW	kg	lbs
TPAH3 30-24	8.601.A064	3400	150	2175	15	9	2,4	6,5	4,8	2	4,40

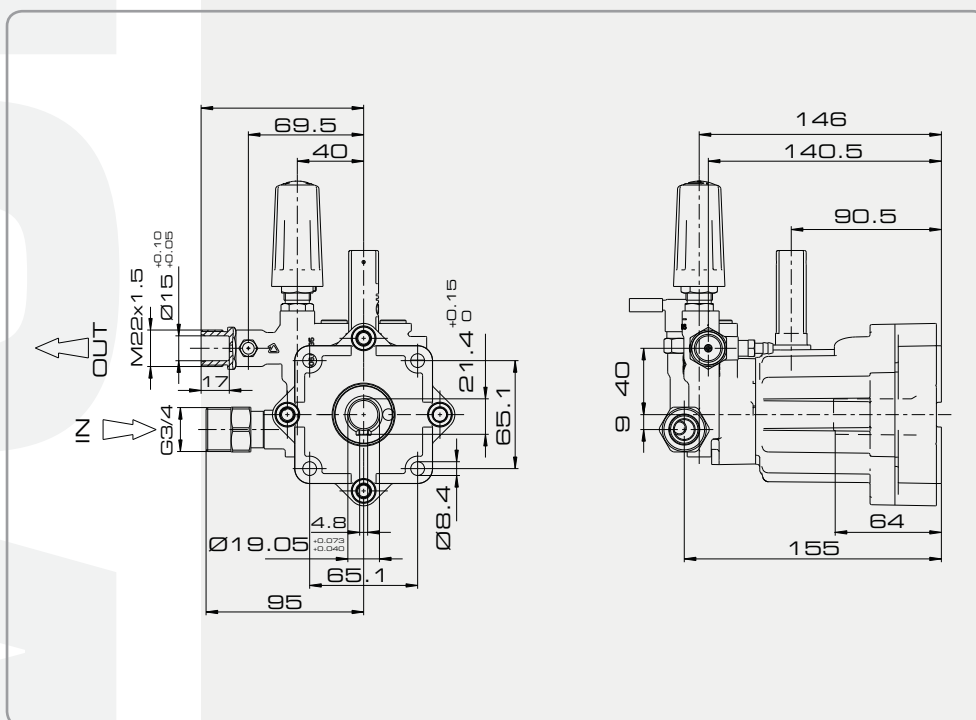

Pompe ad alta pressione per motori a scoppio
Gasoline motor-pumps units

TPBH4

Pompe per motori a scoppio
Gasoline motor-pump units



Modello Model	Codice Code	Giri al min. RPM	Pressione massima Max. pressure			Portata Flow rate		Potenza assorbita Requested power		Peso Weight	
			bar	psi	MPa	l/m	GPM	HP	kW	kg	lbs
TPBH4 30-25	8.601.A046	3400	200	2900	20	9,5	2.5	6,5	4,7	3,7	8,15
TPBH4 30-36	8.601.A063	3400	200	2900	20	13,7	3.6	9	6,6	3,7	8,15

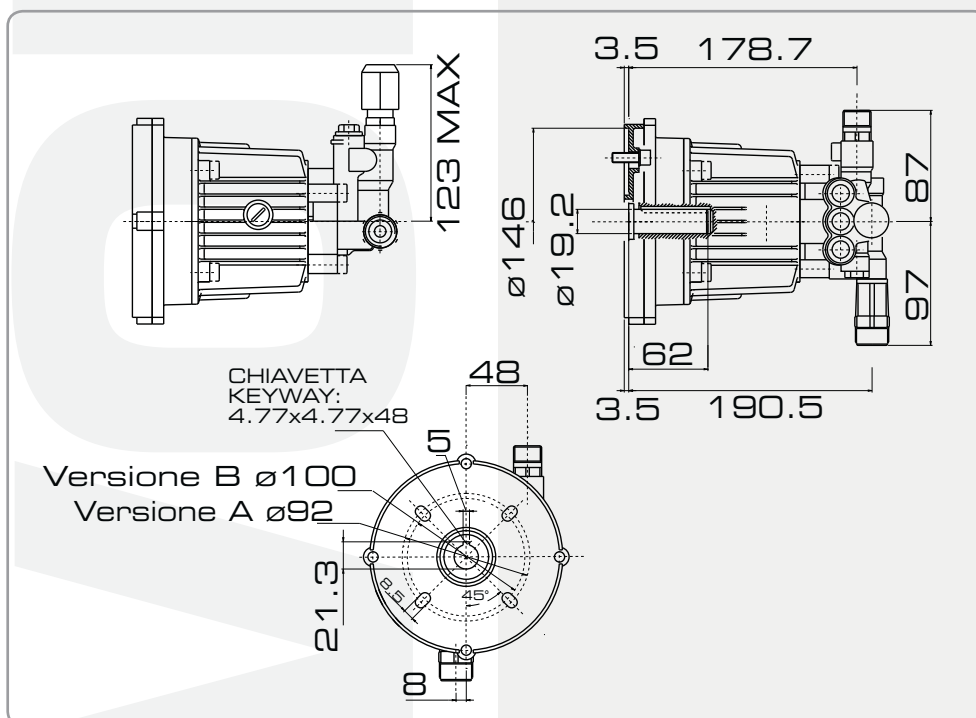

Pompe ad alta pressione per motori a scoppio
Gasoline motor-pumps units

TPBH5



Per valvole termiche
vedi pagina 84
For thermal valves
see page 84

Pompe per motori a scoppio
Gasoline motor-pump units

Modello Model	Ver. albero DX Right shaft ver.	Ver. albero SX Left shaft ver.	Giri al min. RPM	Pressione massima Max. pressure			Portata Flow rate		Potenza assorbita Requested power		Peso Weight	
	Code	Code		bar	psi	MPa	l/m	GPM	HP	kW	kg	lbs
TPBH5 30-29	8.680.0056	8.680.0055	3400	200	2900	20	11	2,9	7,5	5,5	7	15,4
TPBH5 30-35	8.680.0058	8.680.0057	3400	200	2900	20	13	3,5	9	6,6	7	15,4

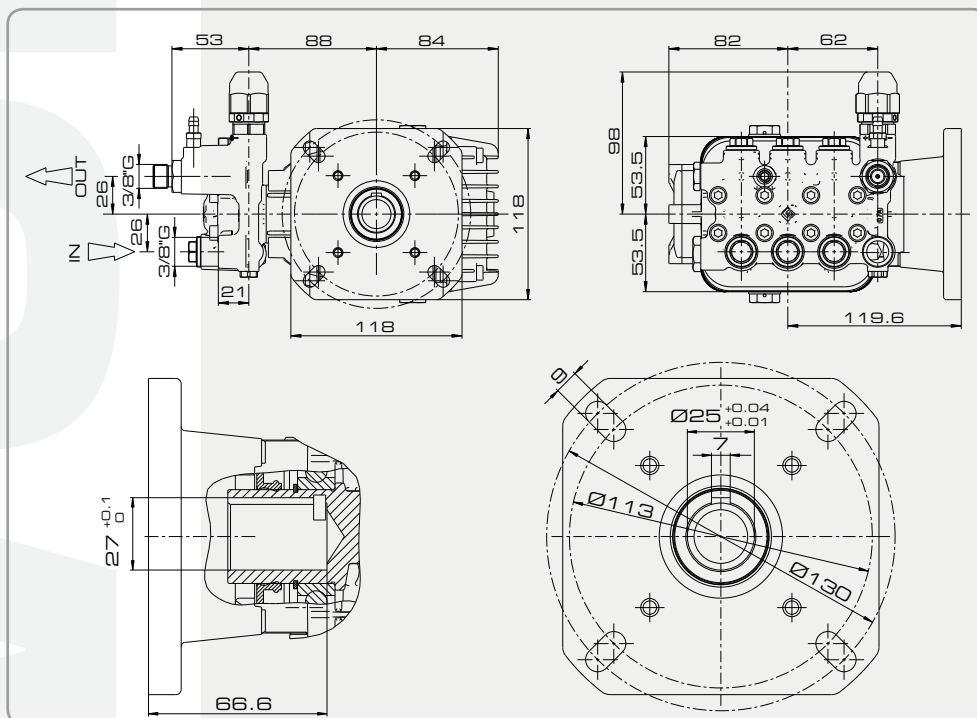

Elettropompe ad alta pressione
High-pressure pumps units

Serie MPW5

Elettropompe ad alta pressione
Electric motor-pump units

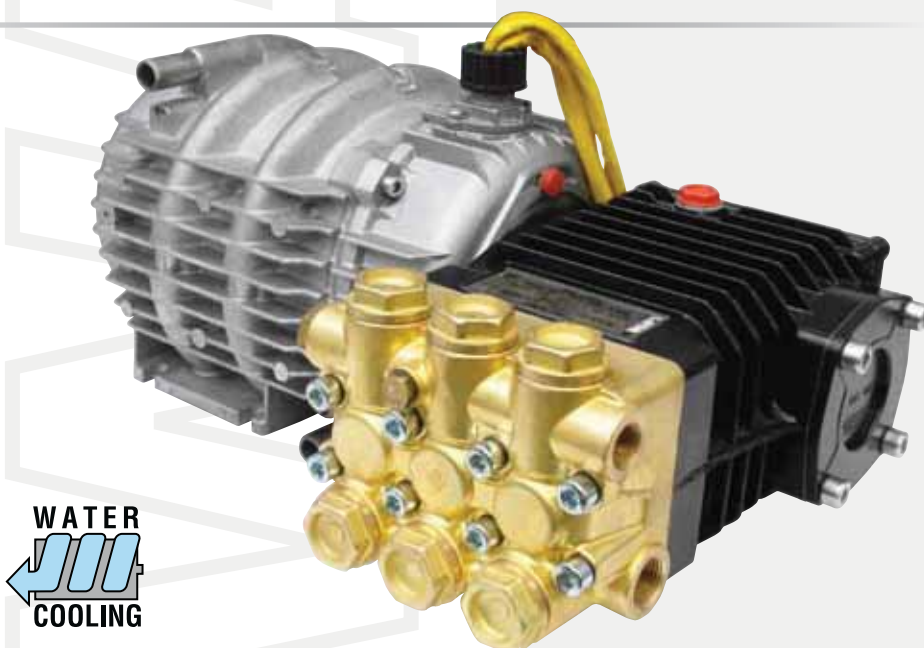

Voltaggio speciale - Special voltage

Modello Model	Ver. albero SX Left shaft ver.	Giri al min. RPM	Pressione massima Max. pressure			Portata Flow rate		Potenza assorbita Requested power	Alimentazione Power supply	Peso Weight	
			bar	psi	MPa	l/m	GPM			kg	lbs
	Code										
MPW 54-20 11-125	8.680.0020	1450	125	1813	12,5	11	2,9	3	1Ph 230V~50Hz	31,5	69,4
MPW 54-20 13-100	8.680.0021	1750	100	1450	10	13	3,4	3	1Ph 220V~60Hz	31,5	69,4
MPW 54-20 15-150	8.680.0022	1450	150	2175	15	15	4	5	3Ph Y 400V~50Hz	32	70,5
MPW 54-20 15-200	8.680.0023	1450	200	2900	20	15	4	7	3Ph Y 400V~50Hz	34	74,9
MPW 54-20 13-200	8.680.0025	1750	200	2900	20	13	3,4	8,4	3Ph Y 400V~60Hz	34	74,9
MPW 54-20 21-200	8.680.0024	1450	200	2900	20	21	5,5	9,4	3Ph Y 400V~50Hz	37	81,5

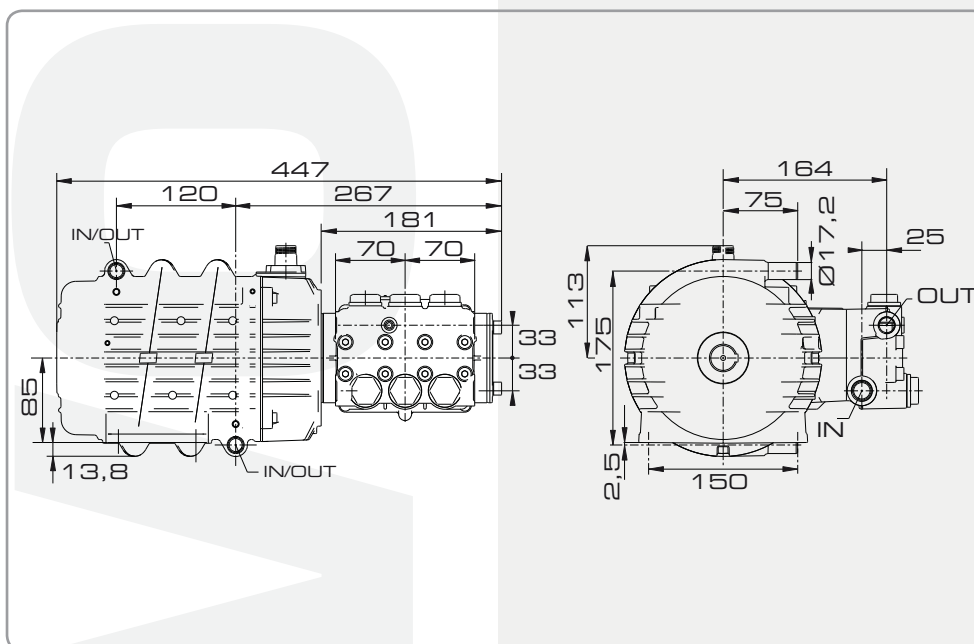

Elettropompe ad alta pressione con giunto elastico
High-pressure pumps units with elastic coupling

Serie MPWJ5



Elettropompe ad alta pressione
Electric motor-pump units

Voltaggio speciale - Special voltage

Modello Model	Ver. albero SX Left shaft ver.	Giri al min. RPM	Pressione massima Max. pressure			Portata Flow rate		Potenza assorbita Requested power	Alimentazione Power supply	Peso Weight	
			bar	psi	MPa	l/m	GPM			kg	lbs
MPWJ 54-20 11-125	8.680.0026	1450	125	1813	12,5	11	2,9	3	1Ph 230V~50Hz	32	70,5
MPWJ 54-20 13-100	8.680.0027	1750	100	1450	10	13	3,4	3	1Ph 220V~60Hz	32	70,5
MPWJ 54-20 15-150	8.680.0028	1450	150	2175	15	15	4	5	3Ph Y 400V~50Hz	32,5	71,6
MPWJ 54-20 15-200	8.680.0029	1450	200	2900	20	15	4	7	3Ph Y 400V~50Hz	34,5	76
MPWJ 54-20 13-200	8.680.0031	1750	200	2900	20	13	3,4	8,4	3Ph Y 400V~60Hz	34,5	76
MPWJ 54-20 21-200	8.680.0030	1450	200	2900	20	21	5,5	9,4	3Ph Y 400V~50Hz	37,5	82,6

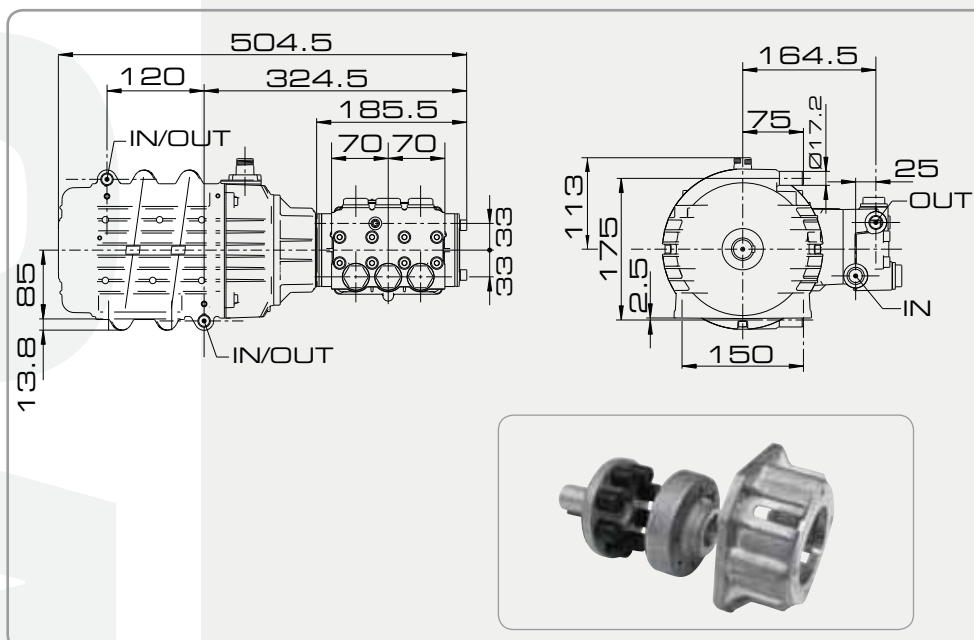

Elettropompe ad alta pressione
High-pressure pumps units

Serie MP3

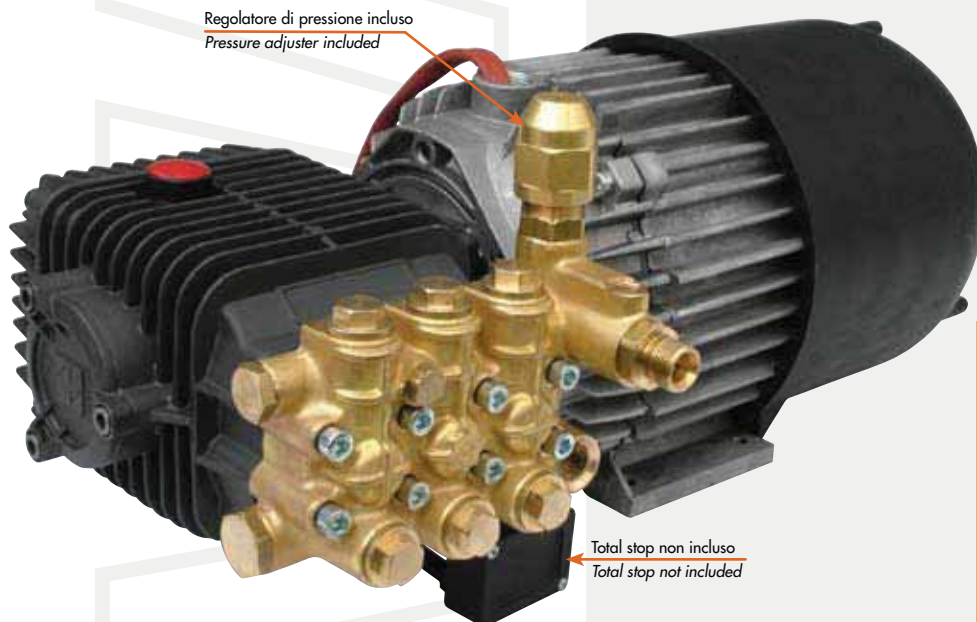

Elettropompe ad alta pressione
Electric motor-pump units



Per versione con Total Stop aggiungere:
For Total Stop version add:

6.005.0288 - Kit Total Stop

+

	230-240 V		24 V
HOT WATER MACHINES MACCHINE ACQUA CALDA 6.005.0293		HOT WATER MACHINES MACCHINE ACQUA CALDA COLD WATER MACHINES MACCHINE ACQUA FREDDA 5.609.0246	
COLD WATER MACHINES MACCHINE ACQUA FREDDA 6.005.0294			

Voltaggio speciale - Special voltage

Modello Model	Ver. albero SX Left shaft ver.	Giri al min. RPM	Pressione massima Max. pressure			Portata Flow rate		Potenza assorbita Requested power	Alimentazione Power supply	Peso Weight	
			bar	psi	MPa	l/m	GPM			kW	kg
MP 34-15 11-120	8.680.0032	1450	120	1740	12	11	2,9	3	1Ph 230V~50Hz	22	49,2
MP 34-15 11-120	8.680.0033	1750	120	1740	12	11	2,9	3	1Ph 220V~60Hz	22	49,2
MP 34-15 15-150	8.680.0034	1450	150	2175	15	11	2,9	4	3Ph Y 400V~50Hz	22,5	49,6
MP 34-15 15-150	8.680.0035	1750	150	2175	15	11	2,9	4	3Ph Y 400V~60Hz	22,5	49,6

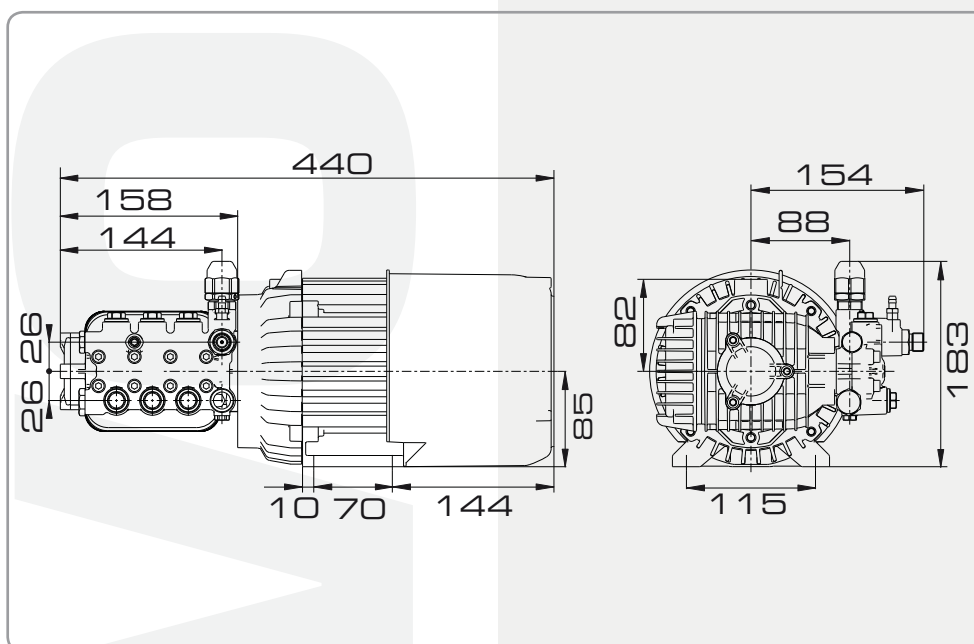

Elettropompe ad alta pressione con giunto elastico
High-pressure pumps units with elastic coupling

Serie MPJ3

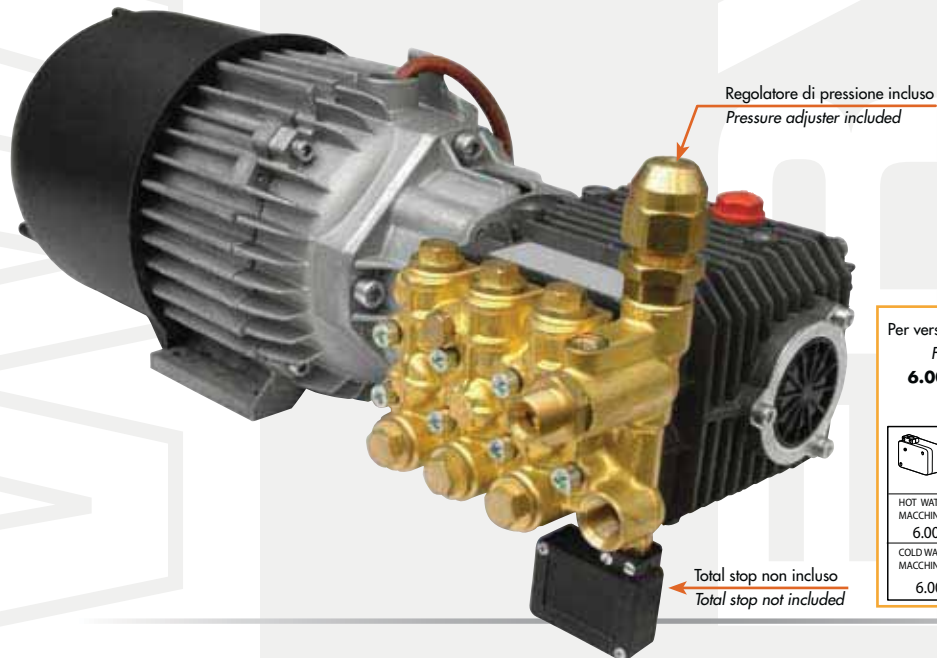

Per versione con Total Stop aggiungere:
For Total Stop version add:
6.005.0288 - Kit Total Stop

230-240V	24V
HOT WATER MACHINES MACCHINE ACQUA CALDA 6.005.0293	HOT WATER MACHINES MACCHINE ACQUA CALDA COLD WATER MACHINES MACCHINE ACQUA FREDDA 5.609.0246
COLD WATER MACHINES MACCHINE ACQUA FREDDA 6.005.0294	

Elettropompe ad alta pressione
Electric motor-pump units

Voltaggio speciale - Special voltage

Modello Model	Ver. albero SX Left shaft ver.	Giri al min. RPM	Pressione massima Max. pressure			Portata Flow rate		Potenza assorbita Requested power	Alimentazione Power supply	Peso Weight	
			bar	psi	MPa	l/m	GPM			kg	lbs
MPJ 34-15 11-120	8.680.0036	1450	120	1740	12	11	2,9	3	1Ph 230V~50Hz	22,5	49,6
MPJ 34-15 11-120	8.680.0037	1750	120	1740	12	11	2,9	3	1Ph 220V~60Hz	22,5	49,6
MPJ 34-15 15-150	8.680.0038	1450	150	2175	15	11	2,9	4	3Ph Y 400V~50Hz	23	50,6
MPJ 34-15 15-150	8.680.0039	1750	150	2175	15	11	2,9	4	3Ph Y 400V~60Hz	23	50,6

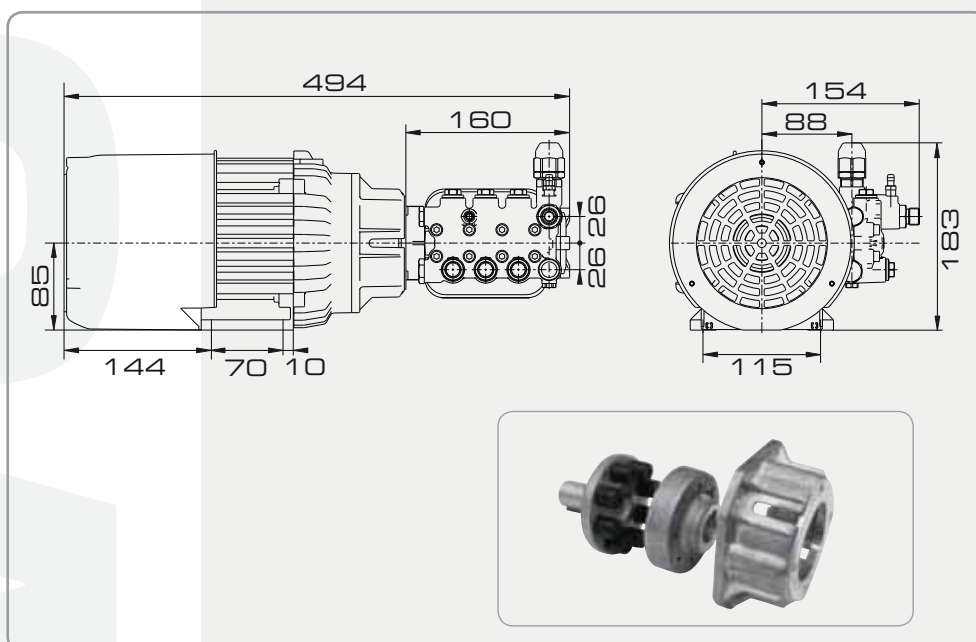

Elettropompe ad alta pressione
High-pressure pumps units

Serie MPW3

Elettropompe ad alta pressione
Electric motor-pump units



Regolatore di pressione incluso
Pressure adjuster included

Total stop non incluso
Total stop not included

Per versione con Total Stop aggiungere:
For Total Stop version add:
6.005.0288 - Kit Total Stop

230-240 V		24 V	
HOT WATER MACHINES MACCHINE ACQUA CALDA 6.005.0293		HOT WATER MACHINES MACCHINE ACQUA CALDA COLD WATER MACHINES MACCHINE ACQUA FREDDA 5.609.0246	
COLD WATER MACHINES MACCHINE ACQUA FREDDA 6.005.0294			

Voltaggio speciale - Special voltage

Modello Model	Ver. albero SX Left shaft ver.	Giri al min. RPM	Pressione massima Max. pressure			Portata Flow rate		Potenza assorbita Requested power	Alimentazione Power supply	Peso Weight	
	Code		bar	psi	MPa	l/m	GPM	kW		kg	lbs
MPW 34-18 15-150	8.680.0040	1450	150	2175	15	15	4	5	3Ph Y 400V~50Hz	28,8	63,5
MPW 34-18 15-200	8.680.0041	1450	200	2900	20	15	4	7	3Ph Y 400V~50Hz	30,8	67,9
MPW 34-15 13-200	8.680.0042	1750	200	2900	20	13	3,4	8,4	3Ph Y 400V~60Hz	28,5	62,8

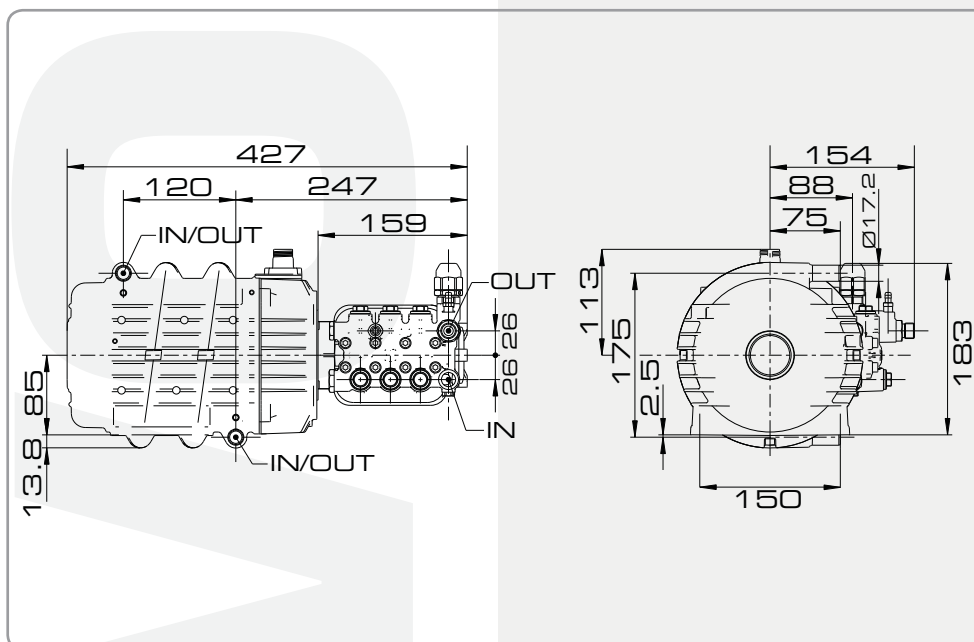

Elettropompe ad alta pressione con giunto elastico
High-pressure pumps units with elastic coupling

Serie MPWJ3



Regolatore di pressione incluso
Pressure adjuster included

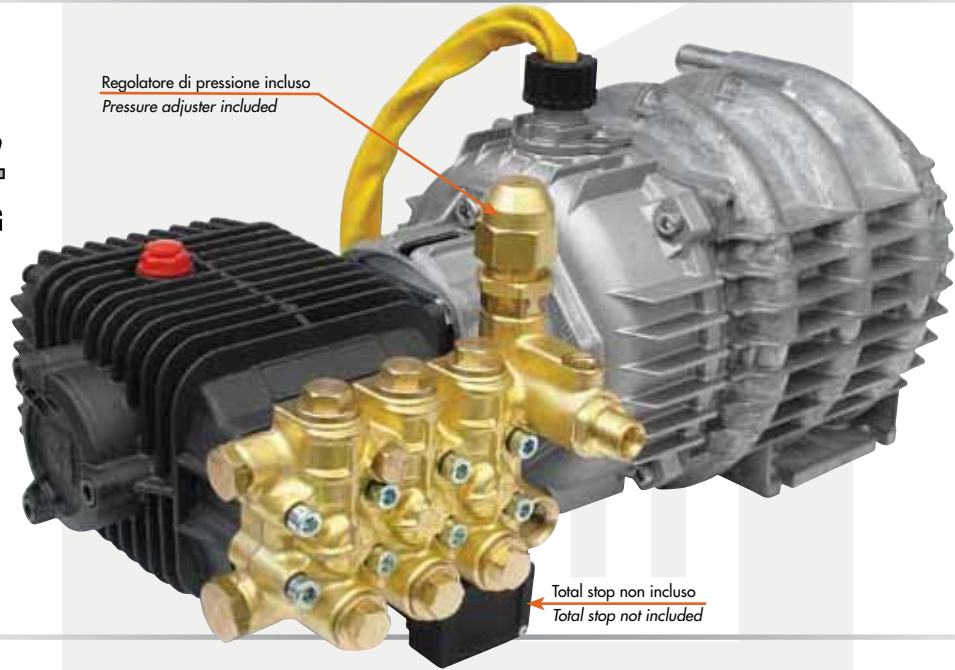

Total stop non incluso
Total stop not included

Per versione con Total Stop aggiungere:
For Total Stop version add:

6.005.0288 - Kit Total Stop

+

230-240 V	24 V
HOT WATER MACHINES MACCHINE ACQUA CALDA 6.005.0293	HOT WATER MACHINES MACCHINE ACQUA CALDA COLD WATER MACHINES MACCHINE ACQUA FREDDA 5.609.0246
COLD WATER MACHINES MACCHINE ACQUA FREDDA 6.005.0294	

Elettropompe ad alta pressione
Electric motor-pump units

Voltaggio speciale - Special voltage

Modello Model	Ver. albero SX Left shaft ver.	Giri al min. RPM	Pressione massima Max. pressure			Portata Flow rate		Potenza assorbita Requested power	Alimentazione Power supply	Peso Weight	
			bar	psi	MPa	l/m	GPM			kW	kg
MPWJ 34-18 15-150	8.680.0043	1450	150	2175	15	15	4	5	3Ph Y 400V~50Hz	29,3	64,6
MPWJ 34-18 15-200	8.680.0044	1450	200	2900	20	15	4	7	3Ph Y 400V~50Hz	31,3	69
MPWJ 34-15 13-200	8.680.0045	1750	200	2900	20	13	3,4	8,4	3Ph Y 400V~60Hz	29	63,9

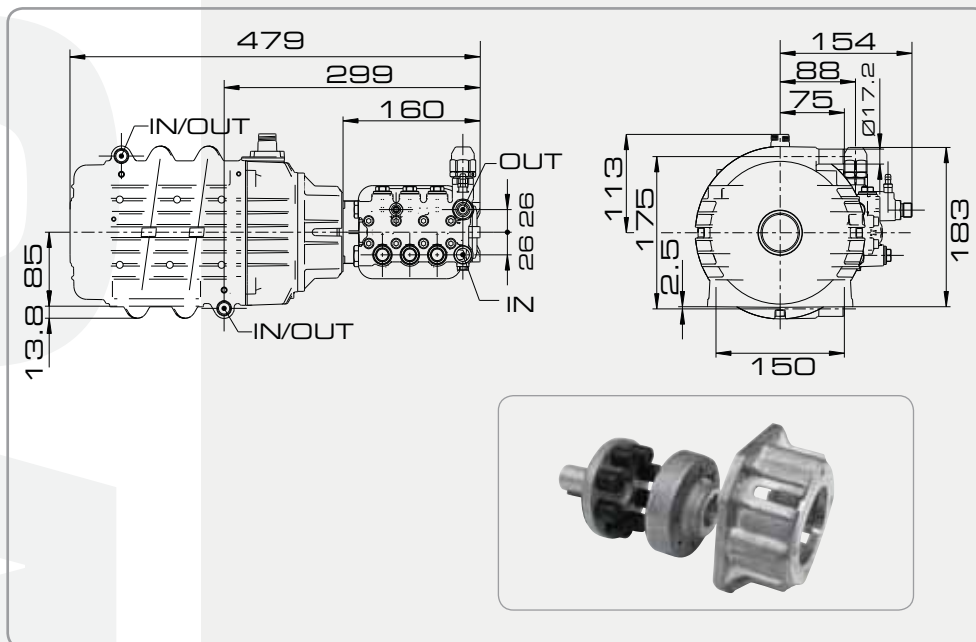

Elettropompe ad alta pressione
High-pressure pumps units

Serie MPWJ3-4/8

Elettropompe ad alta pressione
Electric motor-pump units

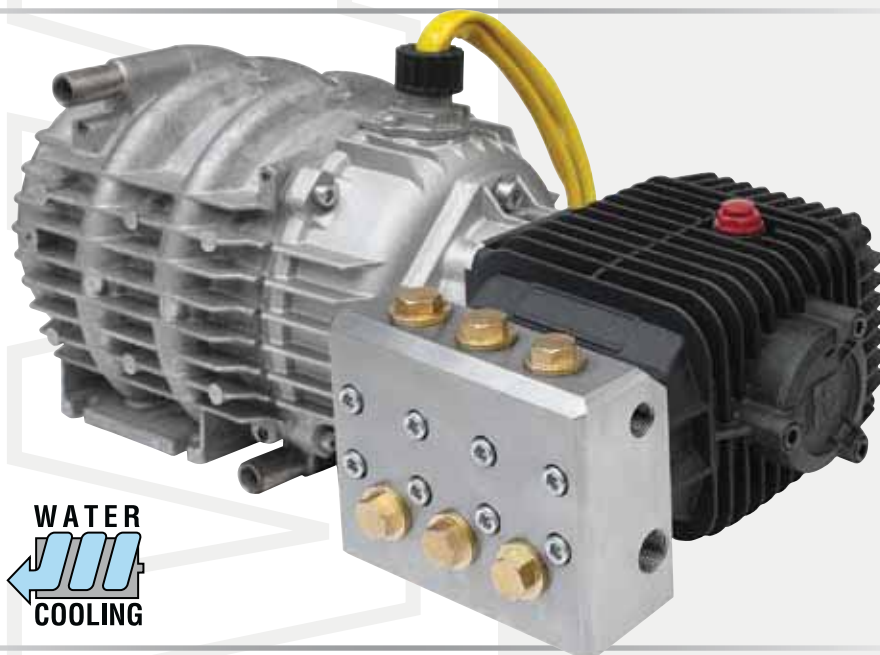

Funzionamento a doppia velocità senza inverter
Double-speed operation without inverter

Modello Model	Ver. albero SX Left shaft ver.	Giri al min. RPM	Pressione massima Max. pressure			Portata Flow rate		Potenza assorbita Requested power	Alimentazione Power supply	Peso Weight	
	Code		bar	psi	MPa	l/m	GPM	kW		kg	lbs
MPW3-4/8	5.601.0534	1450	120	1740	12	11	2,9	3,5	3Ph Y 400V~50Hz	31,3	69
		750	30	435	3	5,5		1,7	3Ph Y 400V~50Hz	31,3	69

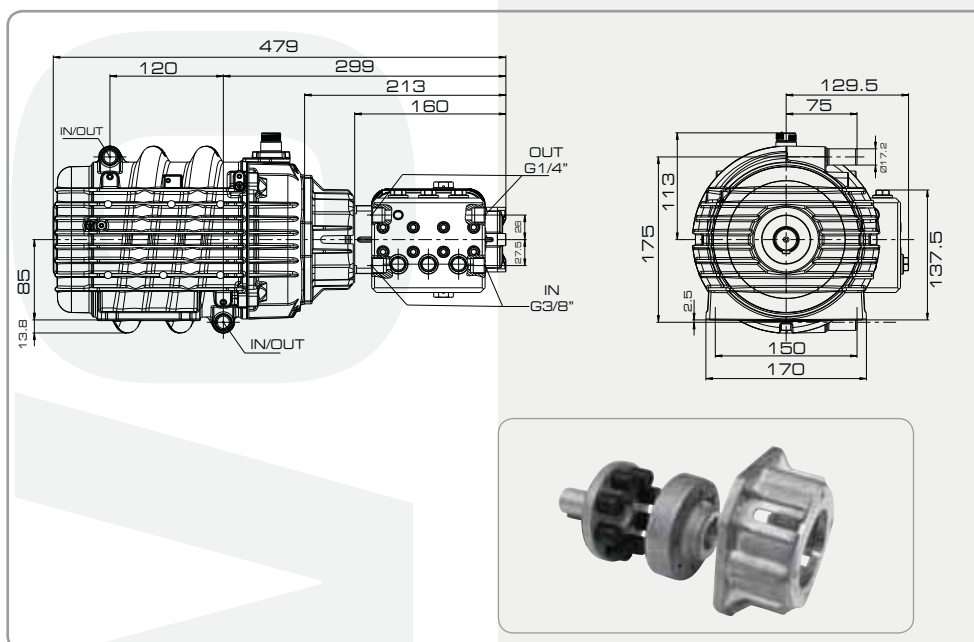

Elettropompe ad alta pressione
High-pressure pumps units

Serie MP2



Elettropompe ad alta pressione
Electric motor-pump units

Voltaggio speciale - Special voltage

Modello Model	Codice Code	Giri al min. RPM	Pressione massima Max. pressure			Portata Flow rate		Potenza assorbita Requested power	Alimentazione Power supply	Peso Weight	
			bar	psi	MPa	l/m	GPM			kg	lbs
MP2 2-12 85-11	8.680.0072	2800	110	1595	11	9	2,4	2,2	1Ph 230V~50Hz	12.5	27.5
MP2 2-12 85-11	8.680.0073	3400	110	1595	11	9	2,4	2,2	1Ph 220V~60Hz	12.5	27.5

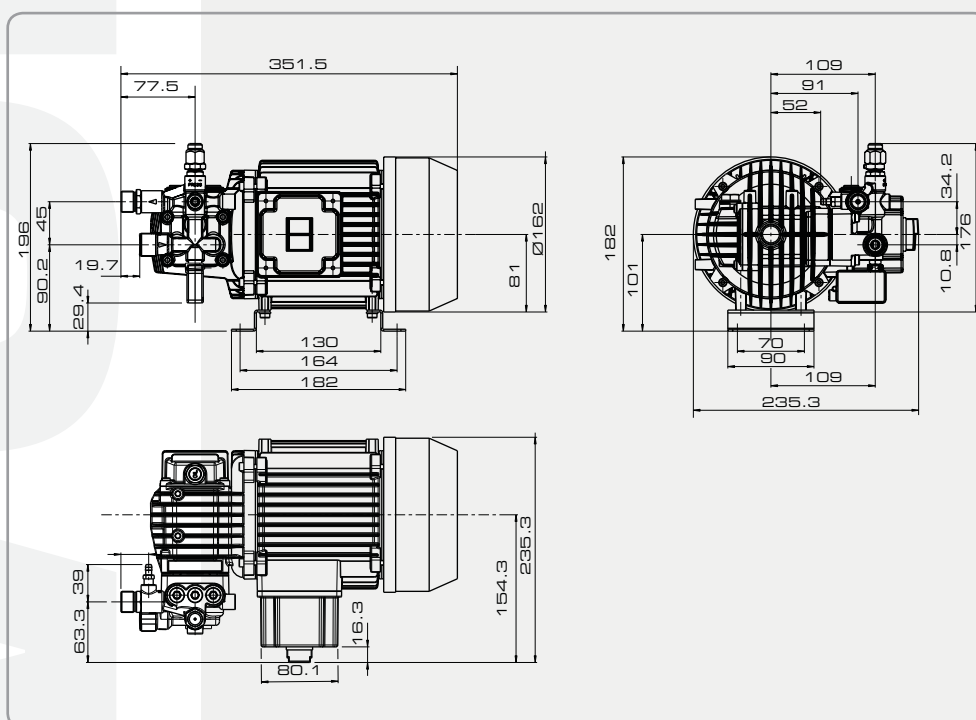

Elettropompe ad alta pressione
High-pressure pumps units

Serie MPBX2

Elettropompe ad alta pressione
Electric motor-pump units



Modello Model	Codice Code	Giri al min. RPM	Pressione massima Max. pressure			Portata Flow rate		Potenza assorbita Requested power kW	Alimentazione Power supply	Peso Weight	
			bar	psi	MPa	l/m	GPM			kg	lbs
MPBX 2-15 11-120	8.680.0046	2800	120	1740	12	11	2,9	3	1Ph 230V~50Hz	20,5	45,2
MPBX 2-15 09-150	8.680.0047	3400	150	2175	15	9	2,4	3	1Ph 220V~60Hz	20,5	45,2
MPBX 2-15 09-160	8.680.0048	3400	160	2320	16	9	2,4	3	3Ph Y 400V~50Hz	21	46,2
MPBX 2-15 07-200	8.680.0049	2800	200	2900	20	7	1,8	3	3Ph Y 400V~50Hz	21	46,2
MPBX 2-15 13-170	8.680.0050	3400	170	2465	17	13	3,4	4,7	3Ph Y 400V~60Hz	21	46,2
MPBX 2-15 11-200	8.680.0051	2800	200	2900	20	11	2,9	4,7	3Ph Y 400V~50Hz	21	46,2
MPBX 2-15 13-170	8.680.0052	3400	170	2465	17	13	3,4	4,7	3Ph Y 400V~50Hz	21	46,2

 Voltaggio speciale - Special voltage

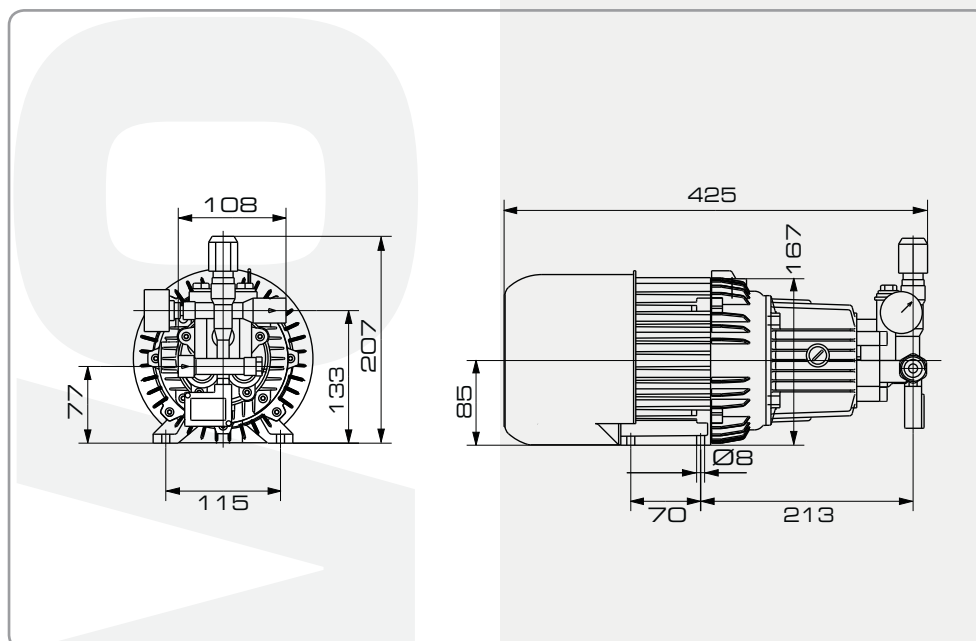

Elettropompe ad alta pressione
High-pressure pumps units

Serie MPAX2 Serie MPNX2



Elettropompe ad alta pressione
Electric motor-pump units

Modello Model	Codice Code	Giri al min. RPM	Pressione massima Max. pressure			Portata Flow rate		Potenza assorbita Requested power	Alimentazione Power supply	Peso Weight	
			bar	psi	MPa	l/m	GPM			kg	lbs
MPAX 2-15 09-130	8.680.0053	2800	130	1885	13	9	2,4	2,6	1Ph 230V~50Hz	14	30,8
MPNX 2-15 09-130	8.680.0054	2800	130	1885	13	9	2,4	2,6	1Ph 230V~50Hz	14	30,8

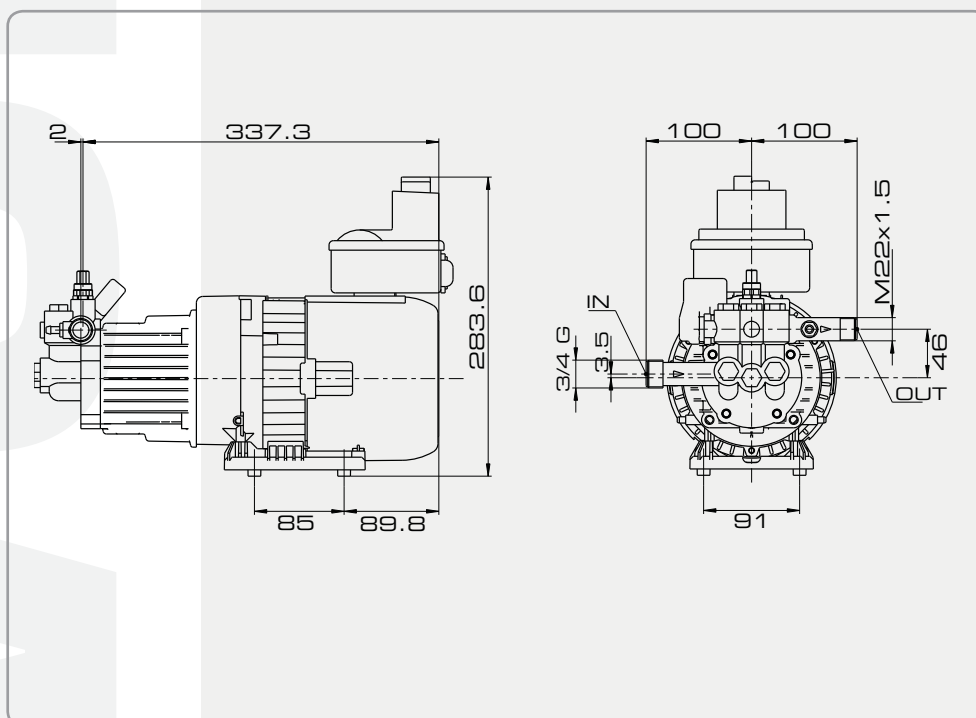

Elettropompe ad alta pressione
High-pressure pumps units

Serie MPBX1

Elettropompe ad alta pressione
Electric motor-pump units

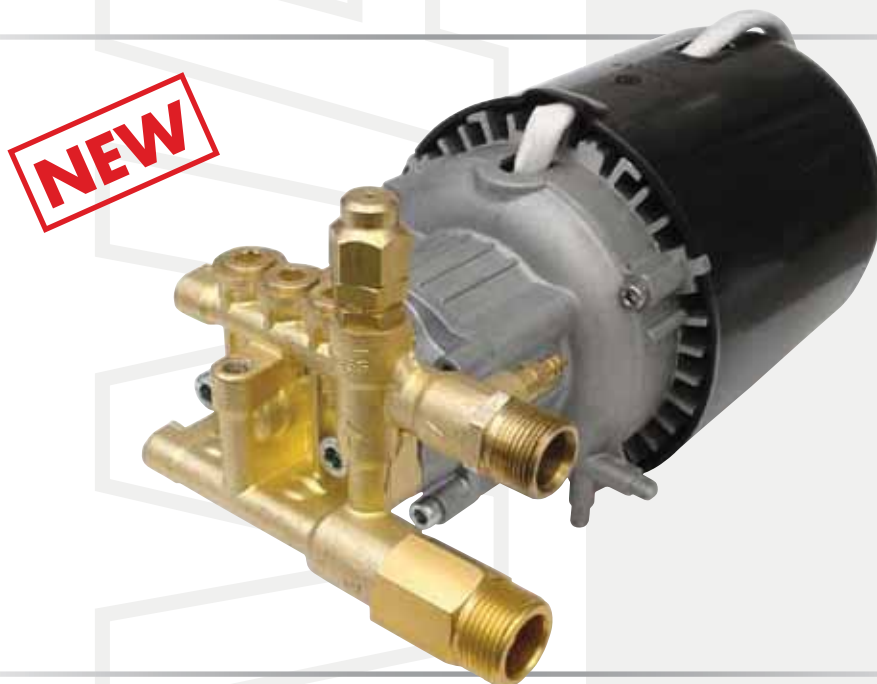

Voltaggio speciale - Special voltage

Modello Model	Codice Code	Giri al min. RPM	Pressione massima Max. pressure			Portata Flow rate		Potenza assorbita Requested power	Alimentazione Power supply	Peso Weight	
			bar	psi	MPa	l/m	GPM			kg	lbs
MPBX 1-12 8-150	8.680.0074	2800	150	2175	15	8	2.11	2.6	1Ph 230V~50Hz	13	28.6
MPBX 1-12 8-150	8.680.0075	3400	150	2175	15	8	2.11	2.6	1Ph 220V~60Hz	13	28.6
MPBX 1-12 65-120	8.680.0076	3400	120	1740	12	6.5	1.72	1.6	1Ph 120V~60Hz	10	22

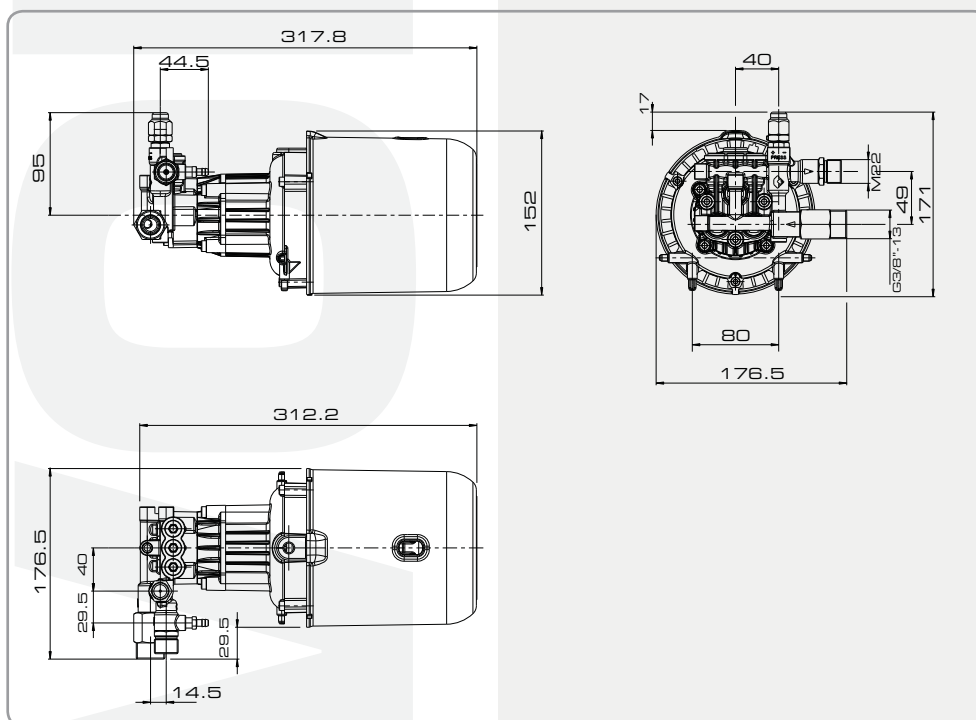

Accessori per pompe ad alta pressione Accessories for high pressure pumps

Flangia per motori a scoppio Flange for gasoline/diesel engines



Codice Code	Adatto a pompa LWS serie: Suitable for LWS pumps series:
3.749.0483	CL3 - HW3 - SS3

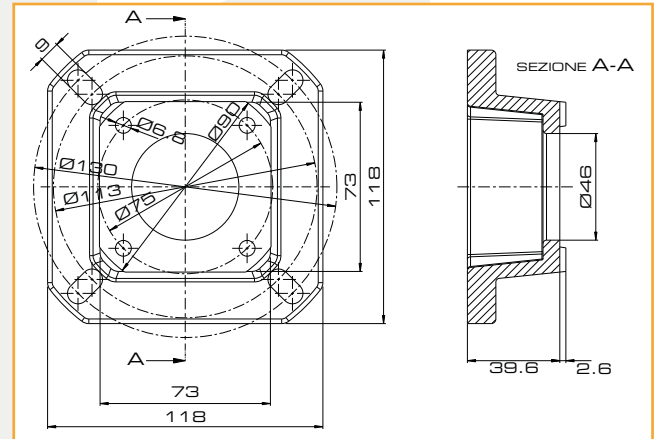

Flangiatura con giunto elastico per motori elettrici Bell housing with flexible coupling for electric motors



Codice Code	Centraggio pompa Pump coupling Ø	Albero Motore Ø Motor Shaft Ø	Albero Pompa Ø Pump Shaft Ø
	mm	mm	mm
6.605.0133	61	24 M	24 F
6.605.0134	90	24 M	24 F

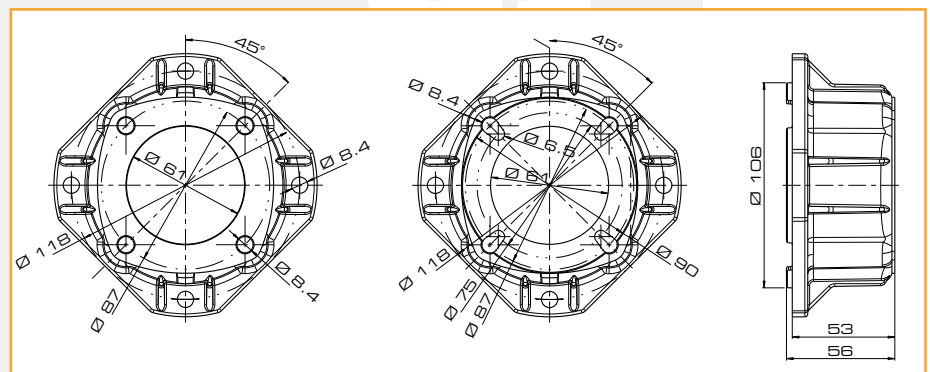

Riduttore di giri per motori a scoppio Reduction gear for gasoline/diesel engines



Codice Code	Rapporto riduz. RR ratio	Flangia motore tipo Engine flange type	Albero Motore Ø Motor Shaft Ø	Centraggio pompa Pump coupling Ø	Albero Pompa Ø Pump Shaft Ø	Taglia motore Engine size
	n1/n2			mm	mm	
3.749.0321	2,176 : 1	SAE J609a	25,4 mm / 1"	61	24 F	9 ÷ 13 HP

Accumulatore idropneumatico ad alta pressione

Pressure dumper



A

Codice Code	Descrizione Description	Pressione Pressure			Portata Flow rate		Attacco Coupling
		bar	psi	MPa	l/m	GPM	A
3.749.0402	Accumulatore idropneumatico ad alta pressione <i>Pressure dumper</i>	300	4351	30	40	10.5	3/8" F

Kit di aspirazione acqua

Water suction kit



Codice Code	Descrizione Description	Profondità di pescaggio Depth of suction
		m
5.012.0319	Kit di aspirazione acqua <i>Water suction kit</i>	2



Parti di ricambio per pompe ad alta pressione Spare parts for high pressure pumps

Anelli di tenuta acqua per pompe ad alta pressione Lavorwash Water seal O-Rings for high pressure pumps Lavorwash

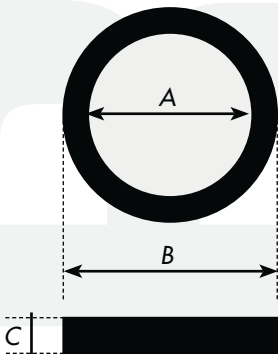

Codice Code	Descrizione Description	Materiale Material	Diametro interno Inner diameter	Diametro Diameter	Altezza Height	Temperatura Temperature		Codice Kit 3 pz. Code Kit 3 pcs.
			(A) mm	(B) mm	(C) mm	°C	°F	
3.201.0020	Anello tenuta acqua Water seal O-Ring	Gomma NBR NBR rubber	12	18	5	40	104	6.005.0080
3.201.0021	Anello tenuta acqua Water seal O-Ring	Tessuto gommato Rubber/fabric	12	18	4.5	90	194	6.005.0145
3.201.0009	Anello tenuta acqua Water seal O-Ring	Gomma NBR NBR rubber	14	22	6	40	104	6.005.0018
3.201.0003	Anello tenuta acqua Water seal O-Ring	Gomma NBR NBR rubber	15	22	4	40	104	6.005.0004
3.201.0006	Anello tenuta acqua Water seal O-Ring	Gomma NBR NBR rubber	15	25	5	40	104	6.005.0034
3.201.0007	Anello tenuta acqua Water seal O-Ring	Tessuto gommato Rubber/fabric	15	22	4	90	194	---
3.201.0018	Anello tenuta acqua Water seal O-Ring	Tessuto gommato Rubber/fabric	15	24	5	90	194	6.005.0118
3.201.0053	Anello tenuta acqua Water seal O-Ring	Gomma NBR NBR rubber	18	25	5.5	40	104	6.005.0305
3.201.0035	Anello tenuta acqua Water seal O-Ring	Gomma NBR NBR rubber	18	26	5.5	40	104	6.005.0221
3.201.0032	Anello tenuta acqua Water seal O-Ring	Tessuto gommato Rubber/fabric	18	28	6	90	194	6.005.0197
3.201.0050	Anello tenuta acqua Water seal O-Ring	Tessuto gommato Rubber/fabric	20	24.7	8	100	212	6.605.0054
3.201.0048	Anello tenuta acqua Water seal O-Ring	Tessuto gommato Rubber/fabric	20	28	5.5	100	212	6.605.0108
3.201.0047	Anello tenuta acqua Water seal O-Ring	Tessuto gommato Rubber/fabric	20	30	6	100	212	6.605.0108
3.201.0041	Anello tenuta acqua Water seal O-Ring	Tessuto gommato Rubber/fabric	20	28	5.5	90	194	6.605.0047
3.201.0049	Anello tenuta acqua Water seal O-Ring	Tessuto gommato A.T. H.T. Rubber/fabric	20	30	10	100	212	6.605.0054
3.201.0001	Anello tenuta acqua Water seal O-Ring	Gomma NBR NBR rubber	20	35	6	40	104	---
3.201.0038	Anello tenuta acqua Water seal O-Ring	Tessuto gommato Rubber/fabric	20	36	6	90	194	6.605.0047
3.201.0011	Anello tenuta acqua Water seal O-Ring	Gomma NBR NBR rubber	35	47	7	40	104	---

Kit anelli di tenuta acqua per pompe Lavorwah

Water seals kit for high pressure pumps Lavorwash



Tipo A
Type A



Tipo B
Type B

Codice Code	Descrizione Description	Diametro pistone Piston diameter	Adatto per pompe: Suitable for pumps:	Temperatura Temperature		Tipo Kit Kit type
				°C	°F	
		mm				
6.005.0133	Kit anelli di tenuta acqua 124 LW Water seal kit 124 LW	12	TPAV	70	158	A
6.005.0316	Kit anelli di tenuta acqua 132 LW Water seal kit 132 LW	12	TPBV	90	194	A
6.605.0088	Kit anelli di tenuta acqua Water seal kit	15	CL3	70	158	A
6.005.0034	Kit anelli di tenuta acqua 33LW Water seal kit 33LW	15	TPBH4	70	158	A
6.005.0004	Kit anelli di tenuta acqua Water seal kit	15	MPAX2	70	158	A
6.005.0221	Kit anelli di tenuta acqua 204 LW Water seal kit 204 LW	18	LWS18	90	194	A
6.005.0265	Kit anelli di tenuta acqua 240 LW Water seal kit 240 LW	18	LWS18	90	194	A
6.005.0305	Kit anelli di tenuta acqua 277 LW Water seal kit 277 LW	18	CL3	90	194	A
6.605.0047	Kit anelli di tenuta acqua Water seal kit	20	CL5	70	158	A
6.605.0041	Kit anelli di tenuta acqua Water seal kit	20	CL5	70	158	A + B
6.605.0108	Kit anelli di tenuta acqua Water seal kit	20	CW5	90	194	A
6.605.0118	Kit anelli di tenuta acqua Water seal kit	20	CW5	90	194	A + B

Anelli di tenuta olio per pompe ad alta pressione Lavorwash

Oil seal O-Rings for high pressure pumps Lavorwash

Codice Code	Descrizione Description	Materiale Material	Diametro interno Inner diameter	Diametro Diameter	Altezza Height	Temperatura Temperature		Codice Kit 3 pz. Code Kit 3 pcs.
			(A) mm	(B) mm	(C) mm	°C	°F	
3.201.0014	Anello tenuta olio Oil seal	Gomma NBR NBR rubber	12	20	5	70	158	6.005.0079
3.201.0004	Anello tenuta olio Oil seal	Gomma NBR NBR rubber	14	22	5	70	158	6.005.0019
3.201.0002	Anello tenuta olio Oil seal	Gomma NBR NBR rubber	15	25	4	70	158	6.005.0006
3.201.0037	Anello tenuta olio Oil seal	Gomma NBR NBR rubber	16	24	5	70	158	6.605.0037
3.201.0016	Anello tenuta olio Oil seal	Gomma NBR NBR rubber	17	28	7	70	158	---
3.201.0008	Anello tenuta olio Oil seal	Gomma NBR NBR rubber	17	35	7	70	158	---
3.201.0031	Anello tenuta olio Oil seal	Gomma NBR NBR rubber	18	26	7	70	158	6.005.0266
3.201.0023	Anello tenuta olio Oil seal	Gomma NBR NBR rubber	22	35	7	70	158	---
3.201.0036	Anello tenuta olio Oil seal	Gomma NBR NBR rubber	25	28	8	70	158	6.605.0050
3.201.0019	Anello tenuta olio Oil seal	Gomma NBR NBR rubber	25	40	7	70	158	6.005.0266
3.201.0058	Anello tenuta olio Oil seal	Gomma NBR NBR rubber	25	62	10	70	158	6.005.0306
3.201.0022	Anello tenuta olio Oil seal	Gomma NBR NBR rubber	30	40	7	70	158	---
3.201.0030	Anello tenuta olio Oil seal	Gomma VITON VITON rubber	30	47	7	90	194	6.005.0203
3.201.0026	Anello tenuta olio Oil seal	Gomma NBR NBR rubber	35	47	7	70	158	---
3.201.0024	Anello tenuta olio Oil seal	Gomma NBR NBR rubber	36	47	7	70	158	---
3.201.0044	Anello tenuta olio Oil seal	Gomma NBR NBR rubber	40	50	7	70	158	---
3.201.0052	Anello tenuta olio Oil seal	Gomma NBR NBR rubber	55	70	8	70	158	---

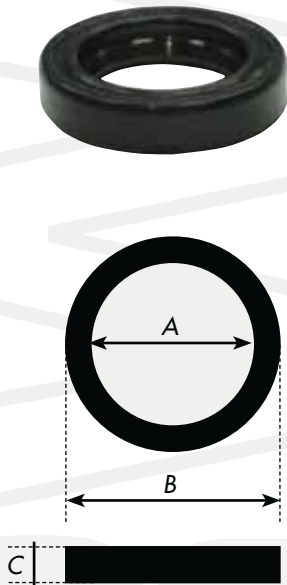

Kit anelli di tenuta olio per pompe ad alta pressione Lavorwash Oil seals kit for high pressure pumps Lavorwash



Codice Code	Descrizione Description	Diametro interno Inner diameter	Diametro Diameter	Altezza Height	Adatto per pompe: Suitable for pumps:
		(A) mm	(B) mm	(C) mm	
6.005.0079	Kit anelli di tenuta olio Oil seal kit	12	20	5	TPBV - TPAV
6.005.0019	Kit anelli di tenuta olio Oil seal kit	14	22	5	PT'02 D.14
6.605.0111	Kit anelli di tenuta olio Oil seal kit	15	24	5	CL3 - HW3
6.005.0006	Kit anelli di tenuta olio Oil seal kit	15	25.4	5	TPBH4
6.605.0037	Kit anelli di tenuta olio Oil seal kit	16	24	5	CL5 - CW5
6.005.0203	Kit anelli di tenuta olio Oil seal kit	18	26	7	LW18
6.005.0306	Kit anelli di tenuta olio Oil seal kit	25	62	10	CL3 - HW3

Valvole di aspirazione-mandata per pompe ad alta pressione Lavorwash Valves for high pressure pumps Lavorwash

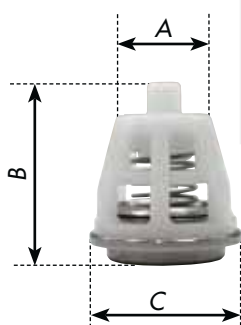

Codice Code	Descrizione Description	Materiale Material	A	B	C	Temperatura Temperature		Codice Kit Code Kit
						°C	°F	
5.609.0137	Assieme valvola aspirazione-mandata Valve assembly	Resina acetale POM + inox Acetalic resin POM + stainless steel	10	19.5	20	90	194	6.005.0198 (6 pcs)
5.009.0005	Assieme valvola aspirazione-mandata Valve assembly	Resina acetale POM Acetalic resin POM	14	17	16	40	104	6.005.0002 (3 pcs)
5.009.0215	Assieme valvola aspirazione-mandata Valve assembly	Resina acetale POM + inox Acetalic resin POM + stainless steel	14	17	16	40	104	6.005.0035 (6 pcs)
5.009.0267	Assieme valvola aspirazione-mandata Valve assembly	Resina acetale POM + inox Acetalic resin POM + stainless steel	14	17	16	40	104	---
5.009.0015	Assieme valvola aspirazione-mandata Valve assembly	Resina acetale POM Acetalic resin POM	14	18.5	18	40	104	6.005.0026 (6 pcs)
5.609.0146	Assieme valvola aspirazione-mandata Valve assembly	Resina acetale POM + inox Acetalic resin POM + stainless steel	14	21	22	90	194	6.605.0042 (6 pcs)
5.609.0180	Assieme valvola aspirazione-mandata Valve assembly	Resina acetale POM + inox Acetalic resin POM + stainless steel	14	21	22	90	194	6.005.0065 (6 pcs)

Kit valvole di aspirazione-mandata per pompe ad alta pressione Lavorwash

Valves kit for high pressure pumps Lavorwash



Codice Code	Descrizione Description	Adatto per pompe: Suitable for pumps:	Portata Flow rate	
			l/m	GPM
6.005.0002	Kit valvole aspirazione - mandata Valves repair kit	MPAX2	15	3.96
6.005.0117	Kit valvole aspirazione - mandata Valves repair kit	CL3 - MPBX2	15	3.96
6.605.0042	Kit valvole aspirazione - mandata Valves repair kit	CL5 - CW5	15	3.96
6.605.0065	Kit valvole aspirazione - mandata Valves repair kit	CL5 - CW5	21	5.55

*

* Intercambiabile al 100% con Kit 1 Interpump
* 100% interchangeable with Kit 1 Interpump

Kit pistoni per pompe ad alta pressione Lavorwash

Pistons kit for high pressure pumps Lavorwash



Tipo A
Type A



Tipo B
Type B



Tipo C
Type C

Codice Code	Descrizione Description	Materiale Material	Diametro interno Inner diameter	Diametro Diameter	Lunghezza Lenght	Tipo Kit Kit type
			mm	mm	mm	
6.605.0117	Kit pistoni 1808 pompe LP Pistons kit 1808 LP pumps	Ceramica Ceramic	11	18	36	A
6.605.0025	Kit pistoni pompe LP Pistons kit LP pumps	Ceramica Ceramic	11	20	46	A
6.605.0040	Kit pistoni pompe LP Pistons kit LP pumps	Ceramica Ceramic	11	20	46	A
6.005.0131	Kit pistoni 122 Pistons kit 122	Acciaio Steel	---	12	61	B
6.005.0144	Kit pistoni 131 Pistons kit 131	Acciaio+ceramica Steel+ceramic	---	12	61	B
6.005.0149	Kit pistoni 136 pompe PT02 Pistons kit 136 PT02 pumps	Acciaio Steel	---	12	61	B + C
6.005.0181	Kit pistoni 167 pompe PT03 Pistons kit 167 PT03 pumps	Acciaio Steel	---	12	61	B + C
6.005.0225	Kit pistoni 208 Pistons kit 208	Acciaio Steel	---	12	61	B + C
6.005.0254	Kit pistoni 237 Pistons kit 237	Acciaio+ceramica Steel+ceramic	---	12	61	B + C
6.005.0072	Kit pistoni 72 Pistons kit 72	Acciaio Steel	---	14	61	B
6.005.0073	Kit pistoni 73 Pistons kit 73	Acciaio+ceramica Steel+ceramic	---	14	61	B
6.605.0090	Kit pistoni 1507 pompe LP Pistons kit 1507 LP pumps	Acciaio+ceramica Steel+ceramic	---	15	79	B
6.005.0097	Kit pistoni 97 Pistons kit 97	Acciaio Steel	---	15	83	B
6.005.0096	Kit pistoni 96 Pistons kit 96	Acciaio+ceramica Steel+ceramic	---	15	83	B
6.005.0267	Kit pistoni 242 Pistons kit 242	Acciaio+ceramica Steel+ceramic	---	18	92	B
6.005.0201	Kit pistoni 187 Pistons kit 187	Acciaio+ceramica Steel+ceramic	---	18	111	B

Bielle per pompe ad alta pressione

Connecting rods for high pressure pumps



Codice Code	Descrizione Description	Costruttore Manufacturer	Materiale Material	Adatto per pompe: Suitable for pumps:
6.605.0112	Biella completa Complete connecting rod	Lavorwash	Bronzo Bronze	CL3
6.605.0026	Biella completa Complete connecting rod	Lavorwash	Alluminio Aluminium	CL5
4.606.0215	Biella completa Complete connecting rod	Lavorwash Comet	Bronzo Bronze	LWR

Valvole di sicurezza per pompe ad alta pressione

Pressure relief valves for high pressure pumps



Codice Code	Descrizione Description	Attacco Thread	Pressione Pressure		
			bar	psi	MPa
3.106.0001	Valvola di sicurezza Pressure relief valve	1/4" M	200	2900	20
5.609.0260	Valvola di sicurezza Pressure relief valve	1/8" M	250	3625	25
3.106.0005	Valvola di sicurezza Pressure relief valve	1/4" M	250	3625	25
3.703.0021	Valvola di sicurezza Pressure relief valve	3/8" M	220	3190	22

Valvole termiche di sicurezza per pompe ad alta pressione

Thermal relief valves for high pressure pumps



Codice Code	Descrizione Description	Attacco Thread	Temperatura Temperature	
			°C	°F
3.106.0023	Valvola di protezione termica Thermal relief valve	1/4" M	50	122
3.703.0006	Valvola di protezione termica Thermal relief valve	3/8" M	63	145

Anelli O-Ring

O-Rings

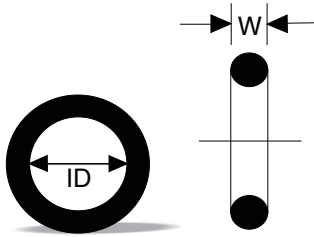

Confezione minima: 20 pezzi o multipli
Packing units : 20 pieces or multiples

Codice Code	Descrizione Description	Diametro interno Inner diameter (ID) mm	Corda Cross section (W) mm	Materiale Material	Durezza Hardness Shore
3.200.0009	Guarnizione O-Ring O-Ring seal	2,9	1,78	NBR	70
3.200.0020	Guarnizione O-Ring O-Ring seal	2,9	1,78	NBR	90
3.200.0007	Guarnizione O-Ring O-Ring seal	3,69	1,78	NBR	70
3.200.0144	Guarnizione O-Ring O-Ring seal	4,48	1,78	NBR	90
3.200.0100	Guarnizione O-Ring O-Ring seal	5	2,5	NBR	70
3.200.0083	Guarnizione O-Ring O-Ring seal	5,28	1,78	NBR	90
3.200.0114	Guarnizione O-Ring O-Ring seal	6	1	NBR	70
3.200.0054	Guarnizione O-Ring O-Ring seal	6,07	1,78	NBR	90
3.200.0021	Guarnizione O-Ring O-Ring seal	6,75	1,78	NBR	70
3.200.0073	Guarnizione O-Ring O-Ring seal	6,75	1,78	NBR	70
3.200.0047	Guarnizione O-Ring O-Ring seal	7,59	2,62	NBR	90
3.200.0010	Guarnizione O-Ring O-Ring seal	7,66	1,78	NBR	70
3.200.0016	Guarnizione O-Ring O-Ring seal	8,73	1,78	NBR	70
3.200.0075	Guarnizione O-Ring O-Ring seal	9	1	NBR	80
3.200.0017	Guarnizione O-Ring O-Ring seal	9,13	2,62	NBR	70
3.200.0022	Guarnizione O-Ring O-Ring seal	9,25	1,78	NBR	70
3.200.0057	Guarnizione O-Ring O-Ring seal	9,25	1,78	NBR	90
3.200.0194	Guarnizione O-Ring O-Ring seal	9,75	1,78	NBR	90
3.200.0001	Guarnizione O-Ring O-Ring seal	9,92	2,62	NBR	70
3.200.0018	Guarnizione O-Ring O-Ring seal	9,92	2,62	NBR	90
3.200.0096	Guarnizione O-Ring O-Ring seal	10	2	NBR	90
3.200.0012	Guarnizione O-Ring O-Ring seal	10,78	2,62	NBR	70
3.200.0030	Guarnizione O-Ring O-Ring seal	10,82	1,78	NBR	70
3.200.0108	Guarnizione O-Ring O-Ring seal	10,82	1,78	NBR	90
3.200.0104	Guarnizione O-Ring O-Ring seal	11	2	NBR	70

Anelli O-Ring

O-Rings

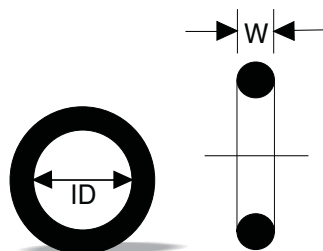

Confezione minima: 20 pezzi o multipli
Packing units : 20 pieces or multiples

Codice Code	Descrizione Description	Diametro interno Inner diameter (ID) mm	Corda Cross section (W) mm	Materiale Material	Durezza Hardness Shore
3.200.0013	Guarnizione O-Ring O-Ring seal	11,1	1,78	NBR	70
3.200.0071	Guarnizione O-Ring O-Ring seal	11,1	1,78	NBR	90
3.200.0090	Guarnizione O-Ring O-Ring seal	11,91	1,78	NBR	70
3.200.0008	Guarnizione O-Ring O-Ring seal	12,37	2,62	NBR	70
3.200.0004	Guarnizione O-Ring O-Ring seal	12,4	1,78	NBR	70
3.200.0019	Guarnizione O-Ring O-Ring seal	12,4	1,78	NBR	90
3.200.0118	Guarnizione O-Ring O-Ring seal	14	1,78	NBR	90
3.200.0113	Guarnizione O-Ring O-Ring seal	15,08	2,62	NBR	70
3.200.0182	Guarnizione O-Ring O-Ring seal	15,47	3,53	NBR	70
3.200.0005	Guarnizione O-Ring O-Ring seal	15,6	1,78	NBR	70
3.200.0080	Guarnizione O-Ring O-Ring seal	15,6	1,78	NBR	90
3.200.0131	Guarnizione O-Ring O-Ring seal	17,13	2,62	NBR	90
3.200.0023	Guarnizione O-Ring O-Ring seal	17,86	2,62	NBR	70
3.200.0162	Guarnizione O-Ring O-Ring seal	18,64	3,53	NBR	70
3.200.0029	Guarnizione O-Ring O-Ring seal	18,72	2,62	NBR	70
3.200.0154	Guarnizione O-Ring O-Ring seal	18,72	2,62	NBR	90
3.200.0027	Guarnizione O-Ring O-Ring seal	20,24	2,62	NBR	70
3.200.0185	Guarnizione O-Ring O-Ring seal	20,29	2,62	NBR	90
3.200.0140	Guarnizione O-Ring O-Ring seal	21,89	2,62	NBR	70
3.200.0046	Guarnizione O-Ring O-Ring seal	21,95	1,78	NBR	70
3.200.0003	Guarnizione O-Ring O-Ring seal	25,12	1,78	NBR	70
3.200.0065	Guarnizione O-Ring O-Ring seal	33,05	1,78	NBR	70
3.200.0168	Guarnizione O-Ring O-Ring seal	36,09	3,53	NBR	70
3.200.0166	Guarnizione O-Ring O-Ring seal	46	2	NBR	70
3.200.0126	Guarnizione O-Ring O-Ring seal	47,22	3,53	NBR	70

Anelli O-Ring O-Rings

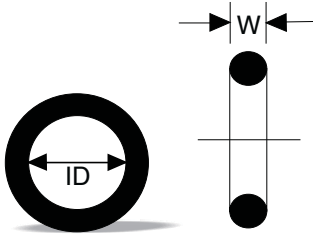

Codice Code	Descrizione Description	Diametro interno Inner diameter (ID) mm	Corda Cross section (W) mm	Materiale Material	Durezza Hardness Shore
3.200.0038	Guarnizione O-Ring O-Ring seal	53,65	2,62	NBR	70
3.200.0173	Guarnizione O-Ring O-Ring seal	58,74	3,53	NBR	70
3.200.0130	Guarnizione O-Ring O-Ring seal	67	2,5	NBR	70
3.200.0172	Guarnizione O-Ring O-Ring seal	69,52	2,62	NBR	70
3.200.0002	Guarnizione O-Ring O-Ring seal	90	2,5	NBR	70
3.200.0015	Guarnizione O-Ring O-Ring seal	117	2,5	NBR	70

Anelli O-Ring in gomma speciale Special rubber O-Rings

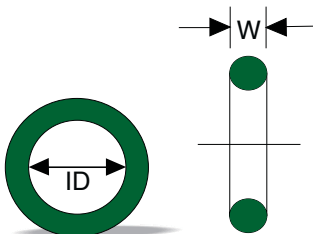

Codice Code	Descrizione Description	Diametro interno Inner diameter (ID) mm	Corda Cross section (W) mm	Materiale Material	Durezza Hardness Shore
3.200.0036	Guarnizione O-Ring O-Ring seal	4	2,5	Viton	70
3.200.0155	Guarnizione O-Ring O-Ring seal	5,23	2,62	Viton	90
3.200.0207	Guarnizione O-Ring O-Ring seal	5,28	1,78	Viton	70
3.200.0119	Guarnizione O-Ring O-Ring seal	7,66	1,78	Viton	90
3.200.0179	Guarnizione O-Ring O-Ring seal	9,25	1,78	Viton	70
3.200.0091	Guarnizione O-Ring O-Ring seal	9,92	2,62	Viton	70
3.200.0043	Guarnizione O-Ring O-Ring seal	6,07	1,78	Molikote Silicone	70
3.200.0055	Guarnizione O-Ring O-Ring seal	7,66	1,78	Molikote Silicone	90
3.200.0062	Guarnizione O-Ring O-Ring seal	8,73	1,78	Molikote Silicone	90
3.200.0093	Guarnizione O-Ring O-Ring seal	15,02	2,62	Molikote Silicone	70
3.200.0068	Guarnizione O-Ring O-Ring seal	9,74	1,78	EPDM	70
3.200.0014	Guarnizione O-Ring O-Ring seal	85	2,5	Nitrile	70

Confezione minima: 20 pezzi o multipli
Packing units : 20 pieces or multiples

Manopola per regolazione pressione

Pressure adjusting knob

Codice - Code
4.608.0314



6.605.0081

Valvola By-Pass L3 per pompe ad alta pressione

By-Pass L3 valve for high pressure pumps

Codice Code	Descrizione Description	Entrata Inlet	Uscita Outlet	Pressione Pressure			Portata Flow rate		Micro switch
				bar	psi	MPa	l/m	GPM	
6.605.0081	Valvola By-Pass L3 By-Pass valve L3	1/2" F	3/8" M	250	3625	25	21	5,56	---

REPAIR KIT "L3" VALVE (INTEGRATED AND SEPARATED) - KIT DI RIPARAZIONE VALVOLA "L3" (INTEGRATA E SEPARATA)

TOTAL STOP VALVE / VALVOLA SENZA T.S.S

TOTAL STOP VALVE / VALVOLA CON T.S.S

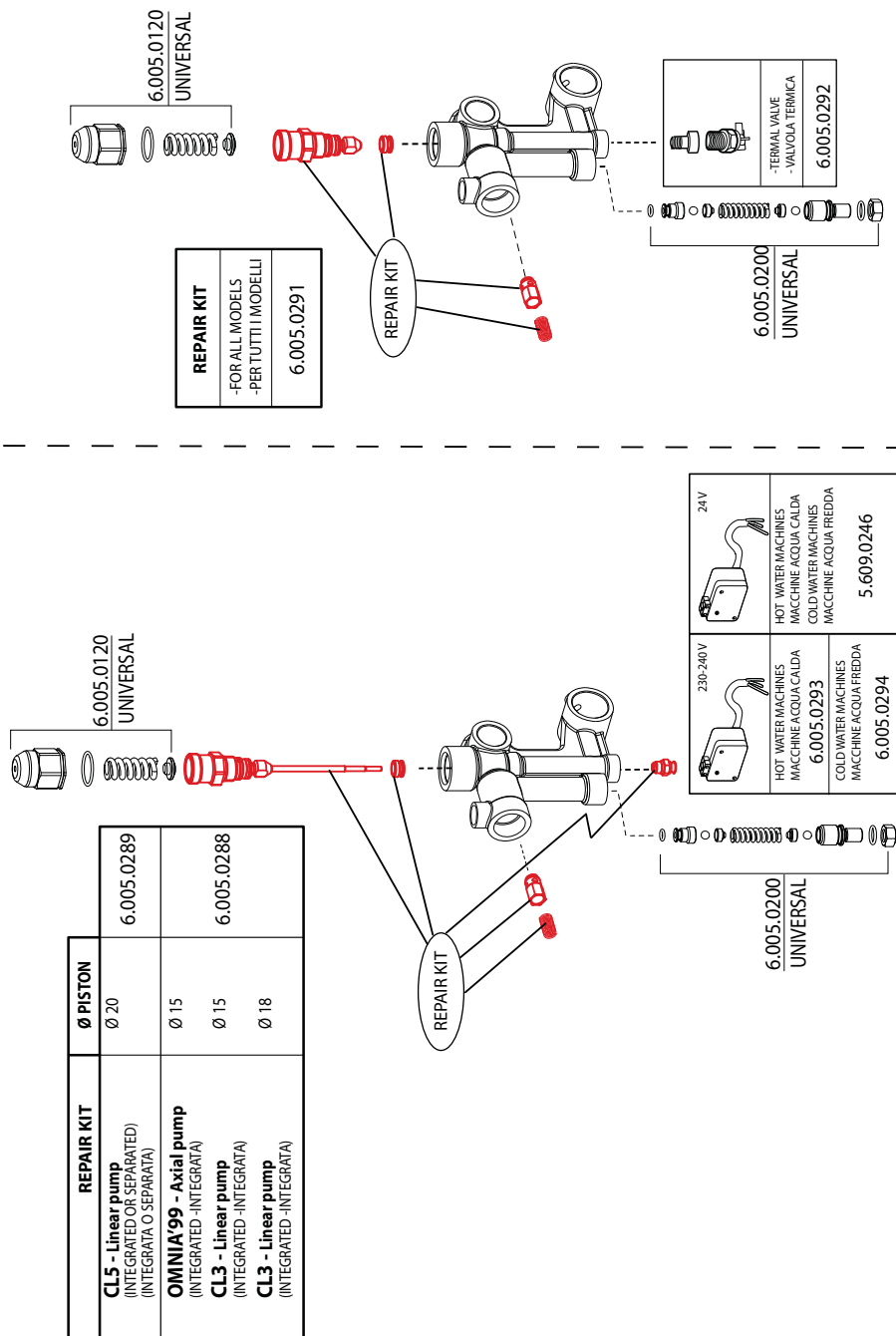

Valvole By-Pass per pompe ad alta pressione

By-Pass valves for high pressure pumps



Codice Code	Descrizione Description	Entrata Inlet	Uscita Outlet	Pressione Pressure			Portata Flow rate		Micro switch
				bar	psi	MPa	l/m	GPM	
3.501.0016	Valvola By-Pass W2-1 By-Pass valve W2-1	1/2" F	3/8" M	200	2900	20	15	3,97	---
3.501.0009	Valvola By-Pass W2L-1 By-Pass valve W2L-1	1/2" F	3/8" M	200	2900	20	15	3,97	---
3.501.0002	Valvola By-Pass W2L-2 By-Pass valve W2L-2	1/2" F	3/8" M	200	2900	20	21	5,56	---



Codice Code	Descrizione Description	Entrata Inlet	Uscita Outlet	Pressione Pressure			Portata Flow rate		Micro switch
				bar	psi	MPa	l/m	GPM	
3.501.0012	Valvola By-Pass K.3.1 By-Pass valve K.3.1	3/8" F	1/2" M	200	2900	20	16	4,23	---
3.501.0007	Valvola By-Pass K.5.1 By-Pass valve K.5.1	3/8" F	1/2" M	200	2900	20	16	4,23	---
3.501.0008	Valvola By-Pass K.5.2 By-Pass valve K.5.2	3/8" F	1/2" M	200	2900	20	25	6,61	---



Codice Code	Descrizione Description	Entrata Inlet	Uscita Outlet	Pressione Pressure			Portata Flow rate		Micro switch
				bar	psi	MPa	l/m	GPM	
3.558.0003	Valvola By-Pass VBA By-Pass valve VBA	3/8" F	3/8" F	250	3625	25	30	7,94	---



Codice Code	Descrizione Description	Entrata Inlet	Uscita Outlet	Pressione Pressure			Portata Flow rate		Micro switch
				bar	psi	MPa	l/m	GPM	
3.703.0004	Valvola By-Pass PULSAR 3 By-Pass valve PULSAR 3	3/8" F	3/8" F	220	3190	22	30	7,94	---
3.703.0003	Valvola By-Pass PULSAR 3 By-Pass valve PULSAR 3	3/8" F	3/8" F	220	3190	22	30	7,94	X



Codice Code	Descrizione Description	Entrata Inlet	Uscita Outlet	Pressione Pressure			Portata Flow rate		Micro switch
				bar	psi	MPa	l/m	GPM	
3.703.0012	Valvola By-Pass PULSAR 280 By-Pass valve PULSAR 280	3/8" F	3/8" F	300	4351	30	30	7,94	---



Codice Code	Descrizione Description	Entrata Inlet	Uscita Outlet	Pressione Pressure			Portata Flow rate		Micro switch
				bar	psi	MPa	l/m	GPM	
3.707.0002	Valvola By-Pass BP9 By-Pass valve BP9	3/8" F	3/8" F	310	4496	31	30	7,94	X



Codice Code	Descrizione Description	Entrata Inlet	Uscita Outlet	Pressione Pressure			Portata Flow rate		Micro switch
				bar	psi	MPa	l/m	GPM	
3.703.0014	Valvola By-Pass VB8 By-Pass valve VB8	3/8" F	3/8" F	250	3625	25	30	7,94	X
3.703.0015	Valvola By-Pass VB8 By-Pass valve VB8	3/8" F	3/8" F	250	3625	25	30	7,94	---



Codice Code	Descrizione Description	Entrata Inlet	Uscita Outlet	Pressione Pressure			Portata Flow rate		Micro switch
				bar	psi	MPa	l/m	GPM	
3.703.0010	Valvola By-Pass VB9 By-Pass valve VB9	3/8" F	3/8" F	250	3625	25	30	7,94	X
3.703.0017	Valvola By-Pass VB9 By-Pass valve VB9	3/8" F	3/8" F	250	3625	25	30	7,94	---

Attacchi rapidi

Quick couplings



3.100.0082

3.100.0342
3.100.00623.100.0043
3.100.0258

3.100.0044



3.100.0018



3.100.0042

3.749.0320
3.749.0463
5.009.0051
5.009.0484

Codice Code	Descrizione Description	Attacco Thread	Attacco Thread
		A	B
3.100.0082	Innesto rapido Quick coupling	3/4"F	Rapido Quick
3.100.0342	Innesto rapido per tubo Hose quick coupling	Rapido Quick	Tubo 1/2" Hose 1/2"
3.100.0062	Innesto rapido con acquastop Hose quick coupling	Rapido Quick	Tubo 1/2" Hose 1/2"
3.100.0006	Innesto rapido per tubo Hose quick coupling	Rapido Quick	Tubo 3/8" Hose 3/8"
3.100.0043	Attacco rapido girevole Quick hand screw coupling	3/8"M	1/2"FØ11
3.749.0258	Attacco rapido girevole Quick hand screw coupling	3/8"M	M24FØ14
3.100.0044	Attacco rapido girevole Quick hand screw coupling	3/8"F	1/2"FØ11
3.100.0018	Innesto rapido Hose coupling	3/8"M	1/2"MØ11
3.100.0042	Innesto rapido Hose coupling	3/8"F	1/2"MØ11
3.749.0320	Innesto rapido Hose coupling	1/4"F	M24MØ14
3.749.0463	Innesto rapido Hose coupling	3/8"F	M22 Ø14
5.009.0051	Innesto rapido Hose coupling	1/4"F	M22 Ø14
5.009.0484	Innesto rapido Hose coupling	1/4"F	M22 Ø15

Kit giardino - 2,5 m

Garden kit - 2.5 m

Codice - Code
6.009.0098

Manicotti

Female thread nipples



Codice Code	Descrizione Description	Attacco Thread	Attacco Thread	Pressione max. Max. pressure		
				bar	psi	MPa
3.100.0338	Manicotto - Female thread nipple	1/8" F	1/4" F	350	5076	35
3.100.0032	Manicotto - Female thread nipple	1/4" F	1/4" F	350	5076	35
3.100.0035	Manicotto - Female thread nipple	3/8" F	3/8" F	350	5076	35
3.100.0039	Manicotto - Female thread nipple	1/2" F	3/8" F	350	5076	35
3.100.0160	Manicotto - Female thread nipple	1/2" F	1/2" F	350	5076	35

Nippli

Nipples



Codice Code	Descrizione Description	Attacco Coupling	Attacco Coupling	Pressione max. Max. pressure		
				A	B	bar
3.100.0047	Niplo - Nipple	1/8" M	1/8" M	350	5076	35
3.100.0093	Niplo - Nipple	1/8" M	1/4" M	350	5076	35
3.100.0021	Niplo - Nipple	1/4" M	1/4" M	350	5076	35
3.100.0022	Niplo - Nipple	3/8" M	1/4" M	350	5076	35
3.100.0023	Niplo - Nipple	3/8" M	3/8" M	350	5076	35
3.100.0098	Niplo - Nipple	1/2" M	1/4" M	350	5076	35
3.100.0020	Niplo - Nipple	1/2" M	3/8" M	350	5076	35
3.100.0019	Niplo - Nipple	1/2" M	1/2" M	350	5076	35
3.100.0095	Niplo - Nipple	3/4" M	3/4" M	350	5076	35
3.100.0335	Niplo - Nipple	1" M	1" M	350	5076	35

Riduzioni

Reduction nipples



Codice Code	Descrizione Description	Attacco Coupling	Attacco Coupling	Pressione max. Max. pressure		
				A	B	bar
3.099.1428	Riduzione - Reduction nipple	1/8" M	1/8" F	350	5076	35
3.100.0079	Riduzione - Reduction nipple	1/8" M	1/4" F	350	5076	35
3.100.0009	Riduzione - Reduction nipple	1/4" M	1/8" F	350	5076	35
3.100.0054	Riduzione - Reduction nipple	1/4" M	3/8" F	350	5076	35
3.100.0031	Riduzione - Reduction nipple	3/8" M	1/4" F	350	5076	35
3.100.0014	Riduzione - Reduction nipple	3/8" M	3/8" F	350	5076	35
3.100.0149	Riduzione - Reduction nipple	3/8" M	1/2" F	350	5076	35
3.100.0046	Riduzione - Reduction nipple	1/2" M	3/8" F	350	5076	35
3.100.0030	Riduzione - Reduction nipple	1/2" M	1/4" F	350	5076	35
3.100.0123	Riduzione - Reduction nipple	3/4" M	1/2" F	350	5076	35
3.100.0128	Riduzione - Reduction nipple	3/4" M	3/4" F	350	5076	35

Portagomma Hose fitting pipes



Codice Code	Descrizione Description	Materiale Material	Attacco Thread	Diametro tubo Hose diameter	Pressione max. Max. pressure		
					bar	psi	MPa
			A	(B) Ø mm			
3.100.0214	Raccordo portagomma a gomito Elbow Hose fitting pipe	Acciaio Steel	1/8" M	7	50	725	5
3.100.0191	Raccordo portagomma dritto Hose fitting pipe	Acciaio Steel	1/4" M	6.5	50	725	5
3.100.0344	Raccordo portagomma a gomito Elbow Hose fitting pipe	Acciaio Steel	1/4" M	10	50	725	5
3.100.0340	Raccordo portagomma dritto Hose fitting pipe	Acciaio Steel	1/4" M	10	50	725	5
3.100.0056	Raccordo portagomma dritto Hose fitting pipe	Acciaio Steel	3/8" M	16	50	725	5
3.100.0339	Raccordo portagomma dritto Hose fitting pipe	Acciaio Steel	3/8" M	16	50	725	5
3.100.0179	Raccordo portagomma dritto Hose fitting pipe	Ottone Brass	1/2" M	12	50	725	5
3.100.0226	Raccordo portagomma dritto Hose fitting pipe	Plastica Plastic	1/2" M	16	50	725	5
3.100.0230	Raccordo portagomma dritto Hose fitting pipe	Plastica Plastic	3/4" M	16	50	725	5
3.100.0354	Raccordo portagomma dritto Hose fitting pipe	Acciaio Steel	3/4" M	16	50	725	5
3.100.0333	Raccordo portagomma dritto Hose fitting pipe	Plastica Plastic	3/4" M	20	50	725	5

Raccordi a gomito Elbows



Codice Code	Descrizione Description	Materiale Material	Attacco Thread	Attacco Thread	Pressione max. Max. pressure		
					bar	psi	MPa
3.100.0040	Raccordo a gomito - Elbow coupling	Acciaio Steel	1/8" M	1/8" M	350	5076	35
3.100.0025	Raccordo a gomito - Elbow coupling	Acciaio Steel	1/8" M	1/8" F	350	5076	35
3.100.0099	Raccordo a gomito - Elbow coupling	Acciaio Steel	1/8" M	1/4" F	350	5076	35
3.100.0028	Raccordo a gomito - Elbow coupling	Ottone Brass	1/4" M	1/4" F	350	5076	35
3.100.0221	Raccordo a gomito - Elbow coupling	Acciaio Steel	1/4" M	1/4" F	350	5076	35
3.100.0177	Raccordo a gomito - Elbow coupling	Acciaio Steel	1/4" M	1/4" M	350	5076	35
3.100.0091	Raccordo a gomito - Elbow coupling	Acciaio Steel	3/8" M	3/8" F Girevole-Swivel	350	5076	35
3.100.0041	Raccordo a gomito - Elbow coupling	Acciaio Steel	3/8" M	3/8" M	350	5076	35
3.100.0033	Raccordo a gomito - Elbow coupling	Ottone Brass	3/8" M	3/8" F	350	5076	35
3.100.0094	Raccordo a gomito - Elbow coupling	Acciaio Steel	3/8" F	3/8" F Girevole-Swivel	350	5076	35
3.100.0008	Raccordo a gomito - Elbow coupling	Acciaio Steel	3/8" F	3/8" F	350	5076	35
3.100.0357	Raccordo a gomito - Elbow coupling	Acciaio Steel	1/2" M	1/2" M	350	5076	35
3.100.0074	Raccordo a gomito - Elbow coupling	Acciaio Steel	1/2" M	1/2" F	350	5076	35
3.100.0087	Raccordo a gomito - Elbow coupling	Ottone Brass	1/2" M	1/2" F	350	5076	35
3.100.0120	Raccordo a gomito - Elbow coupling	Acciaio Steel	3/4" M	3/4" F	350	5076	35
3.100.0119	Raccordo a gomito - Elbow coupling	Acciaio Steel	3/4" M	3/4" M	350	5076	35

Raccordi a T T connections



Codice Code	Descrizione Description	Materiale Material	Attacco Thread	Attacco Thread	Attacco Thread	Pressione max. Max. pressure		
						bar	psi	MPa
3.100.0143	Raccordo a T - T connection	Acciaio Steel	1/8" M	1/8" F	1/8" F	350	5076	35
3.100.0216	Raccordo a T - T connection	Acciaio Steel	1/8" M	1/8" M	1/8" M	350	5076	35
3.100.0213	Raccordo a Y - Y connection	Acciaio Steel	1/8" F	1/8" F	1/8" F	350	5076	35
3.100.0096	Raccordo a T - T connection	Acciaio Steel	1/8" F	1/8" F	1/8" F	350	5076	35
3.100.0118	Raccordo a T - T connection	Acciaio Steel	1/4" M	1/4" F	1/4" M	350	5076	35
3.100.0193	Raccordo a T - T connection	Acciaio Steel	1/4" F	1/4" F	1/4" M	350	5076	35
3.100.0187	Raccordo a T - T connection	Acciaio Steel	1/4" F	1/4" M	1/4" F	350	5076	35
3.100.0159	Raccordo a Y - Y connection	Acciaio Steel	1/4" F	1/4" F	1/4" F	350	5076	35
3.100.0202	Raccordo a T - T connection	Acciaio Steel	3/8" F	3/8" M	3/8" F	350	5076	35
3.100.0016	Raccordo a T - T connection	Acciaio Steel	1/2" F	1/2" F	1/2" M	350	5076	35
3.100.0053	Raccordo a T - T connection	Acciaio Steel	1/2" F	1/2" M	1/2" M	350	5076	35
3.100.0142	Raccordo a T - T connection	Acciaio Steel	1/2" F	1/2" F	1/2" F	350	5076	35
3.100.0111	Raccordo a T - T connection	Acciaio Steel	1/2" F	1/2" M	1/2" M	350	5076	35
3.100.0145	Raccordo a T - T connection	Acciaio Steel	1/2" F	1/2" F	1/2" M	350	5076	35
3.100.0127	Raccordo a T - T connection	Acciaio Steel	3/4" F	3/4" F	3/4" F	350	5076	35
3.100.0126	Raccordo a T - T connection	Ottone Brass	3/4" F	3/4" F	3/4" M	350	5076	35

Tappi Plugs



Codice Code	Descrizione Description	Attacco Coupling
4.606.0001	Tappo - Plug	1/4" M
3.100.0084	Tappo - Plug	1/2" M

Caldaie complete per idropultrici ad alta pressione Complete boilers for high-pressure cleaners



M-top / Alta / Bassa

Modello Model	Codice Code	Pressione massima Max. pressure			Portata Flow rate		Potenza assorbita Requested power W	Alimentazione (*) Power supply (*)	Potenza termica Thermal power	Serpentina Coil length	Dimensioni Dimension		Peso Weight	
		bar	psi	Mpa	l/m	GPM					kg	lbs		
M-Top	8.690.0044	200	2900	20	12	3.17	300	230V ~ 50Hz	49000 Kcal/h	20 m	405 mm (A) - 510 mm (B)		38	85,9
Bassa	8.690.0001	200	2900	20	15	3.96	300	230V ~ 50Hz	63000 Kcal/h	29,5 m	465 mm (A) - 565 mm (B)		48,5	106,8
Alta	8.690.0002	200	2900	20	21	5.55	300	230V ~ 50Hz	63000 Kcal/h	36,5 m	600 mm (A) - 690 mm (B)		54	120

(*) Disponibile in vari voltaggi / Available in various voltages

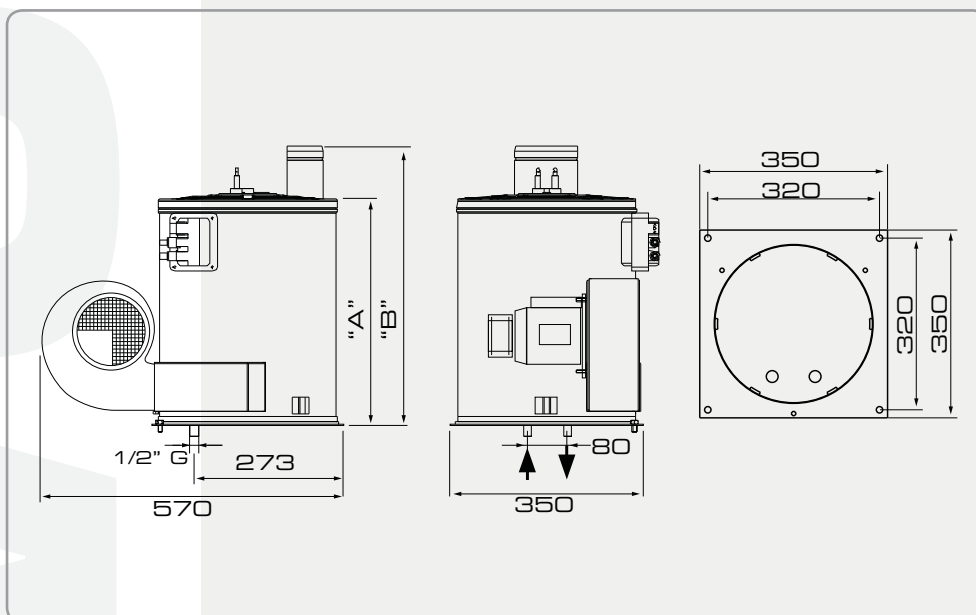

Compact

NEW

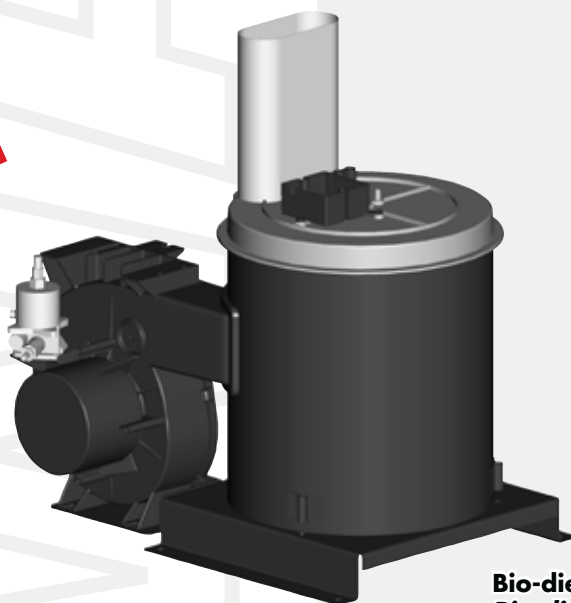

Bio-diesel compatibile
Bio-diesel compatible

Modello Model	Codice Code	Pressione massima Max. pressure			Portata Flow rate		Potenza assorbita Requested power	Alimentazione (*) Power supply (*)	Potenza termica Thermal power	Serpentina Coil length	Dimensioni Dimension	Peso Weight		
		bar	psi	Mpa	l/m	GPM	W					kg	lbs	
COMPACT 11	8.690.0081	200	2900	20	11	2.90	280	230V ~ 50Hz	40100 Kcal/h	17 m	392 mm (A) - 581 mm (B)		35	77.2
COMPACT 15	8.690.0082	200	2900	20	15	3.96	280	230V ~ 50Hz	50000 Kcal/h	17 m	392 mm (A) - 581 mm (B)		40	88.2

(*) Disponibile in vari voltaggi / Available in various voltages

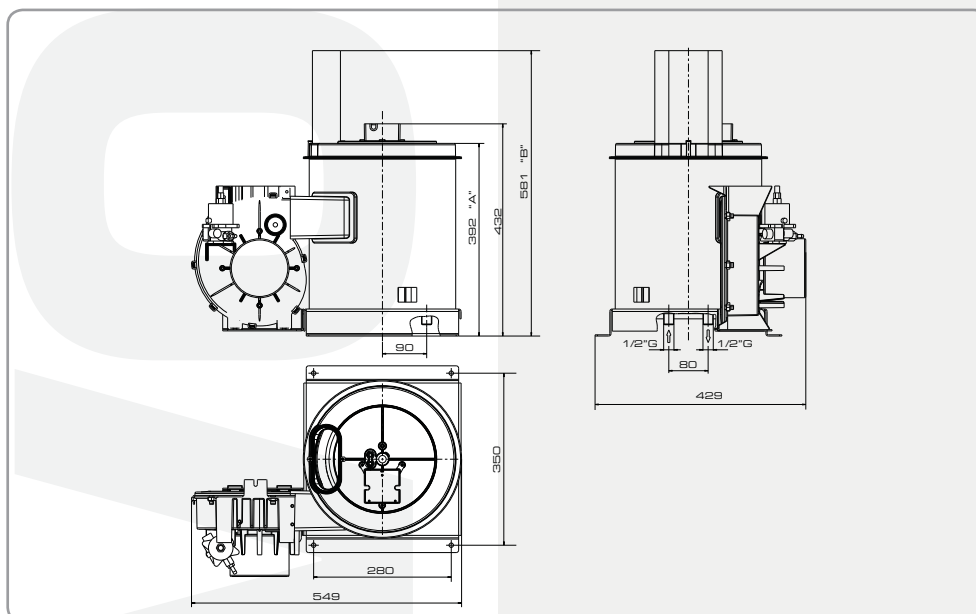

Alta 08 / Bassa 08



Modello Model	Codice Code	Pressione massima Max. pressure			Portata Flow rate		Potenza assorbita Requested power	Alimentazione (*) Power supply (*)	Potenza termica Thermal power	Serpentina Coil length	Dimensioni Dimension		Peso Weight	
		bar	psi	Mpa	l/m	GPM	W					kg	lbs	
Bassa 08	8.690.0069	200	2900	20	15	3.96	300	230V ~ 50Hz	49.000 Kcal/h	28 m	471 mm (A) - 587 mm (B)		50	110,2
Alta 08	8.690.0070	200	2900	20	21	5.55	300	230V ~ 50Hz	73.500 Kcal/h	34 m	586 mm (A) - 702 mm (B)		62,4	137,5

(*) Disponibile in vari voltaggi / Available in various voltages

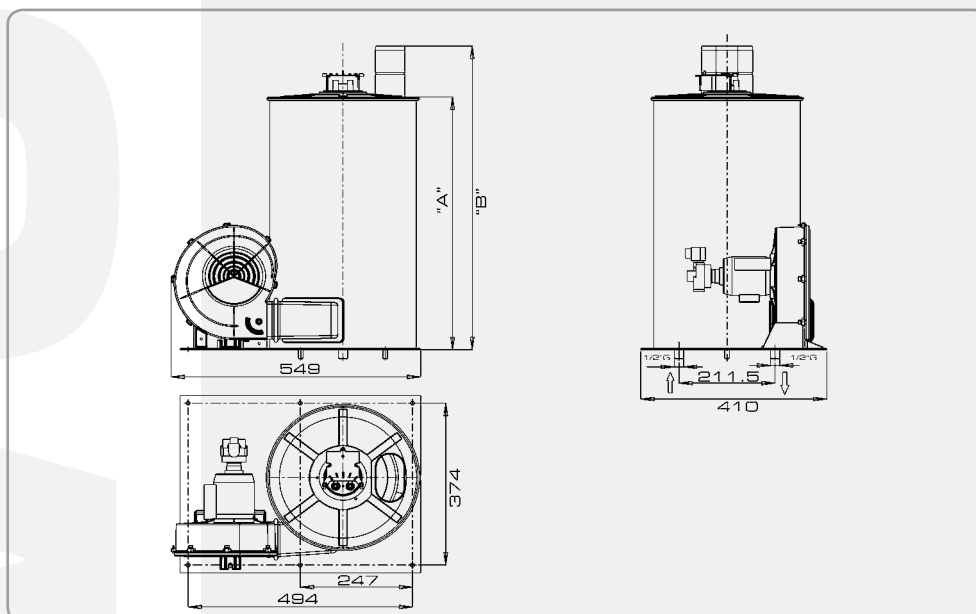

Caldia diesel completa a vapore

Complete steam boiler diesel driven

PED
Conformity
Certification

NEW

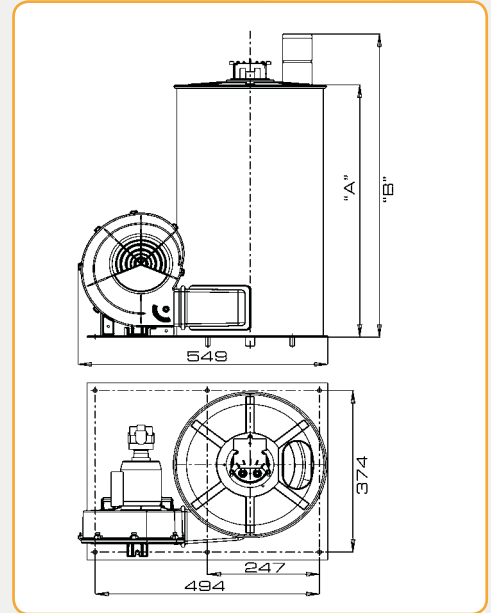

Modello Model	Codice Code	Pressione massima Max. pressure			Portata Flow rate		Potenza assorbita Requested power	Alimentazione Power supply	Potenza termica Thermal power	Serpentina Coil	Dimensioni Dimension	Peso Weight	
		bar	psi	Mpa	l/m	GPM	W	V/Hz			kg	lbs	
Kolumbo	su richiesta on request	12	174	1.2	37.5	9.92	350	230/50	190° max	Inox	(A)586 - (B)702	70	154

Serpentina completa per caldaia diesel a vapore

Complete coil for steam boiler diesel driven

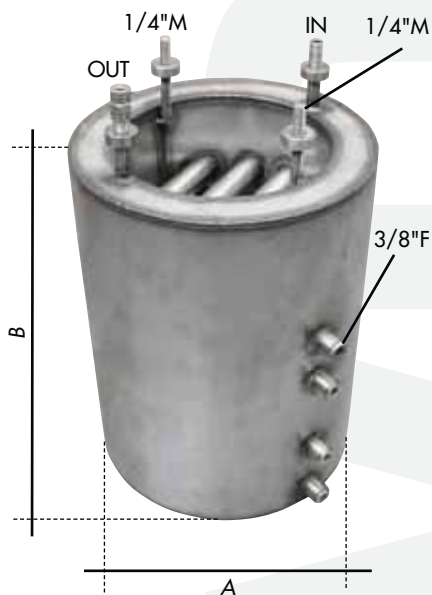

Codice Code	Pressione massima Max. pressure			Portata Flow rate		A	B	IN	OUT	Peso Weight		Materiale Material
	bar	psi	Mpa	l/m	GPM	mm	mm			kg	lbs	
5.613.0305	12	174	1.2	37.5	9.92	286	370	1/4\"M	1/4\"M	13	29	Inox

Caldia elettrica completa

Complete electric boiler

NEW

Ingresso con controllo di flusso con elettrovalvola
Water inlet with solenoid valve control



Elemento per riscaldamento acqua
Water heating device

Sensori di livello acqua e temperatura
Water level and temperature sensors

Modello Model	Codice Code	Pressione massima Max. pressure			Portata Flow rate		Potenza assorbita Requested power	Alimentazione (*) Power supply (*)	Temperatura Temperature		Dimensioni Dimension	Peso Weight	
		bar	psi	Mpa	l/m	GPM			°C	°F		kg	lbs
Caldia elettrica	5.600.0037	150	2175	15	11	2.9	24000	380V ~ 50-60 Hz	60	140	386 mm (Ø) - 541 mm (h)	6,5	14.33

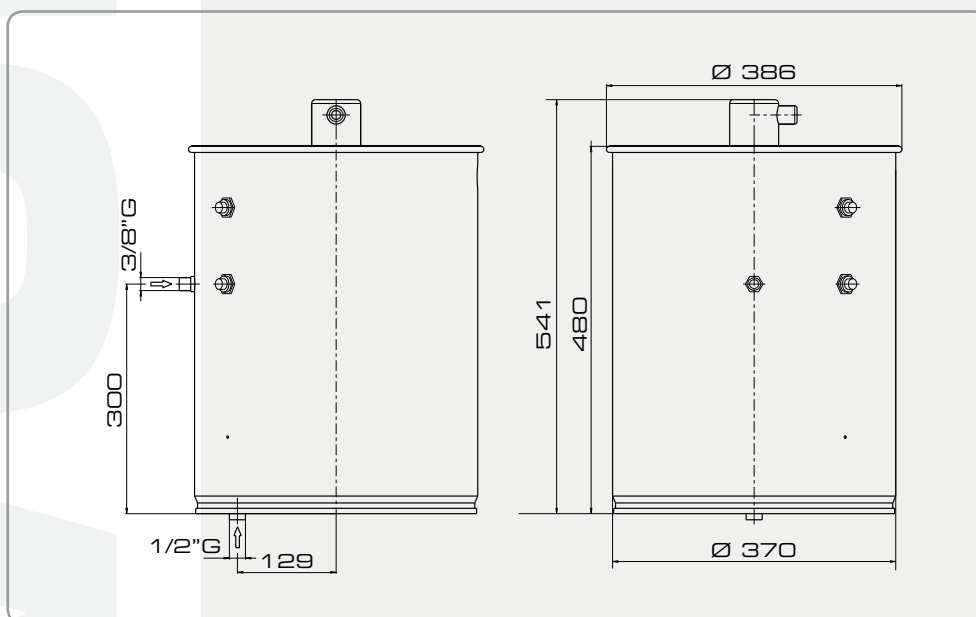

Parti di ricambio per caldaie Spare parts for boilers

Serpentine Coils

Tipo A
Type A



Tipo B
Type B



Tipo C
Type C



Codice Code	Descrizione Description	Attacco Connection		Materiale Material	Ø Tubo Pipe Ø	Spessore Thickness	Pressione Pressure (max)	Portata Flow rate (max)	Dimensioni (mm) Dimensions (mm)			Tipo Type
		IN	OUT						mm	mm	bar	
4.604.0001	Serpentina Top Coil Top	1/2" M	1/2" M	FE 35.2	19	2.3	200	12	80	335	286	A
4.604.0002	Serpentina Hobby Coil Hobby	3/8" M	3/8" M	FE 35.2	17	2.2	200	12	80	365	204	A
4.604.0003	Serpentina bassa Low Coil	1/2" M	1/2" M	FE 35.2	17	2.3	200	15	80	415	286	A
4.604.0004	Serpentina alta High Coil	1/2" M	1/2" M	FE 35.2	17	2.3	200	21	80	500	278	A
4.604.0005	Serpentina tubo SS Coil SS pipe	3/8" M	3/8" M	C14 SS	17	2.5	200	15	80	415	280	A
4.604.0007	Serpentina tubo SS Coil SS pipe	3/8" M	3/8" M	C14 SS	17	2.5	200	15	80	380	280	A
4.604.0010	Serpentina alta Inox Coil SS pipe	1/2" M	1/2" M	INOX	17	2.5	200	21	80	500	280	A
4.604.0012	Serpentina bassa Inox Inox Low Coil	1/2" M	1/2" M	INOX	17	2.5	200	15	80	415	286	A
4.604.0013	Serpentina bassa Alto Rend. High Performance Low Coil	1/2" M	1/2" M	FE 37	17.2	2.3	200	15	80	425	280	A
4.604.0014	Serpentina alta Alto Rend. High Performance High Coil	1/2" M	1/2" M	FE 37	17.2	2.3	200	21	80	470	278	A
4.604.0018	Serpentina Top Inox Inox Coil Top	1/2" M	1/2" M	INOX	17	2.5	200	12	80	335	286	A
4.604.0019	Serpentina Alto Rend. Inox High Performance Inox Coil	1/2" M	1/2" M	INOX	17	2.5	200	21	80	500	278	A
4.604.0022	Serpentina bassa Tekna '04 Low Coil Tekna '04	1/2" M	1/2" M	FE 37	17.2	2.3	200	15	212	425	280	A
4.604.0025	Serpentina alta SuperTekna High Coil SuperTekna	1/2" M	1/2" M	FE 37	17.2	2.3	200	21	212	500	278	A
4.604.0029	Serpentina Eco Coil Eco	M17M	M14F	FE 37	17	2.1	200	12	140	265	202	A
4.604.0011	Serpentina Fire Coil Fire	3/8" M	3/8" M	FE 37	17	2	200	12	(*) Opp.	296	202	B
4.604.0031	Serpentina Paraná Coil Paraná	3/8" M	3/8" F	FE 37	17	2.2	200	12	(*) Opp.	400	202	B
4.604.0032	Serpentina caldaia compact Coil for boiler compact	1/2" M	1/2" M	FE 37	17.2	2.3	200	15	80	303	266	C

(*) Gli attacchi sono posti orizzontalmente, uno opposto all'altro (IN e OUT in linea)
The connections are placed horizontally, opposite one to each other (IN and OUT in line)

NEW
Altissimo rendimento
Very high efficiency

PED
Conformity
Certification

Refrattari

Refractory stones



Codice Code	Descrizione Description	Diametro Diameter	Spessore Thickness	Kit completo per caldaia Complete Kit for boiler
		mm	mm	code
4.008.0450	Refrattario Hobby FKX/RIO/XTR/KAPPA <i>Refractory stone Hobby FKX/RIO/XTR/KAPPA</i>	Speciale <i>Special</i>	10	6.605.0141 Kit refrattari Hobby <i>Kit refractory stones Hobby</i>
4.008.0658	Refrattario aggiuntivo Hobby FKX/RIO/XTR/KAPPA A <i>Additional Refractory stone Hobby FKX/RIO/XTR/KAPPA A</i>	Speciale <i>Special</i>	6	
4.008.0503	Fascia termoresistente Hobby FKX/RIO/XTR/KAPPA A <i>Heat resistant belt FKX/RIO/XTR/KAPPA A</i>	120 x 635	4	
4.008.0449	Manicotto termoresistente Hobby FKX/RIO/XTR/KAPPA A <i>Heat resistant sleeve Hobby FKX/RIO/XTR/KAPPA A</i>	56x31	3	
4.608.0116	Refrattario cementato <i>Cemented refractory stone</i>	290	20	6.605.0142 Kit refrattari Pro <i>Kit refractory stones Pro</i>
4.608.0144	Refrattario cementato <i>Cemented refractory stone</i>	205	20	---
4.608.0193	Refrattario cementato <i>Cemented refractory stone</i>	290	40	---
4.608.0202	Refrattario cementato <i>Cemented refractory stone</i>	299	20	6.605.0143 Kit refrattari Pro Serie "4" <i>Kit refractory stones Pro Series "4"</i>
4.608.1269	Refrattario cementato <i>Cemented refractory stone</i>	204	20	---
4.008.1174	Fascia termoresistente <i>Heat resistant belt</i>	270 x 635	4	---
4.608.0162	Corda isolante <i>Heat insulating rope</i>	325	12	6.605.0142 Kit refrattari Pro <i>Kit refractory stones Pro</i>
4.608.0218	Spessore isolante <i>Insulating thickness</i>	321	3	6.605.0143 Kit refrattari Pro Serie "4" <i>Kit refractory stones Pro Series "4"</i>

Pompe gasolio elettriche

Electrical fuel pumps

Kit di revisione per pompa CEME AGM 200

Maintenance kit for CEME AGM 2000 pump

Codice/Code: 6.605.0144



Codice Code	Descrizione Description	Tipo Type	Alimentazione bobina	Pressione max.
			Coil power supply	Max pressure
			V/Hz	bar
3.551.0018	Pompa gasolio CEME AMG 2000 90W Fuel pump CEME AMG 2000 90W	Elettrica Electric	230-240/50-60	15
3.551.0014	Pompa gasolio ULKA EP 5 48W Fuel pump ULKA EP 5 48W	Elettrica Electric	230/50	15
3.551.0016	Pompa gasolio ULKA EAP5 52W Fuel pump ULKA EAP5 52W	Elettrica Electric	120/60	15
3.551.0017	Pompa gasolio ULKA EP 5 48W Fuel pump ULKA EP 5 48W	Elettrica Electric	240/50	15
3.551.0020	Pompa gasolio ULKA EP 5 48W Fuel pump ULKA EP 5 48W	Elettrica Electric	200/50-60	15
3.551.0048	Pompa gasolio LAVOR VSC 36 19VA Fuel pump LAVOR VSC 36 19VA	Elettrica Electric	230/50-60	15
3.551.0041	Pompa gasolio LAVOR VSC 36 19VA Fuel pump LAVOR VSC 36 19VA	Elettrica Electric	240/50	15



Pompe gasolio meccaniche

Mechanical fuel pumps

Codice Code	Descrizione Description	Tipo Type	Alimentazione bobina	Pressione max.
			Coil power supply	Max pressure
			V/Hz	bar
3.551.0037	Pompa gasolio bitubo DANFOSS Double pipe fuel pump DANFOSS	Meccanica Mechanical	230/50	16
3.551.0040	Pompa gasolio bitubo DANFOSS Double pipe fuel pump DANFOSS	Meccanica Mechanical	24/50-60	16
3.551.0044	Pompa gasolio bitubo DANFOSS Double pipe fuel pump DANFOSS	Meccanica Mechanical	110/50-60	16



Giunto per pompa gasolio

Plastic joint for diesel pump



Codice/Code: 3.749.0463

Bobine per pompe gasolio meccaniche

Coils for mechanical fuel pumps

Codice Code	Descrizione Description	Tipo Type	Alimentazione bobina
			Coil power supply
			V/Hz
3.414.0001	Bobina per pompa gasolio Coil for fuel pump	DELTA	24/50
3.414.0002	Bobina per pompa gasolio Coil for fuel pump	DELTA	230/50
3.414.0010	Bobina per pompa gasolio Coil for fuel pump	DANFOSS	230/50
3.414.0009	Bobina per pompa gasolio Coil for fuel pump	DANFOSS	24/50
3.414.0011	Bobina per pompa gasolio Coil for fuel pump	DANFOSS	110/50-60



Voltaggio speciale - Special voltage



Ugelli gasolio

Fuel nozzles

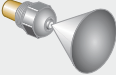

Codice Code	Descrizione Description	Portata Flow rate	Angolo Angle	Tipo Type
		GPM		
3.104.0006	Ugello gasolio Fuel nozzle	0.85	60°	A
3.104.0028	Ugello gasolio Fuel nozzle	1.25	45°	B
3.104.0027	Ugello gasolio Fuel nozzle	1.50	45°	B
3.104.0008	Ugello gasolio Fuel nozzle	0.60	60°	H
3.104.0003	Ugello gasolio Fuel nozzle	1.00	60°	H
3.104.0002	Ugello gasolio Fuel nozzle	1.75	60°	H
3.104.0014	Ugello gasolio Fuel nozzle	2.00	60°	H
3.104.0007	Ugello gasolio Fuel nozzle	0.75	60°	S
3.104.0020	Ugello gasolio Fuel nozzle	1.35	45°	S
3.104.0018	Ugello gasolio Fuel nozzle	1.75	60°	S

Tabella di confronto dei produttori ugelli gasolio
Fuel nozzles manufacturer comparison chart

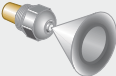
		Steinen	Danfoss	Monarch	Delavan	Hago
	Pieno Solid	S	S/SR	AR/A	B	ES/B/P
	Vuoto Hollow	H	H/HR	NS/PL	A	H
	Semivuoto Half Hollow	Q	B	PLS/PLP	W	SS

Filtri gasolio

Diesel filters



Codice Code	Descrizione Description	Attacco Connection	
		IN	OUT
3.102.0004	Filtro gasolio in alluminio Aluminium fuel filter	1/4" F	1/4" F
3.102.0005	Filtro gasolio FB15/P Fuel filter FB15/P	---	---
3.102.0006	Filtro gasolio in linea FB6A (in carta - 30 micron) Inline fuel filter FB6A (paper - 30 micron)	---	---
3.102.0017	Filtro gasolio in linea FB1 (in carta - 30 micron) Inline fuel filter FB1 (paper - 30 micron)	---	---

Motori di ventilazione per bruciatori

Burner ventilation motors



Codice Code	Descrizione Description	Tensione	Frequenza	Potenza
		Voltage	Frequency	Power
		V	Hz	W
3.300.0003	Motore di ventilazione per bruciatore - <i>Burner ventilation motor</i>	230-240	50	100
3.300.0004	Motore di ventilazione per bruciatore - <i>Burner ventilation motor</i>	115	60	100
3.300.0005	Motore di ventilazione per bruciatore - <i>Burner ventilation motor</i>	230	50-60	100
3.300.0011	Motore di ventilazione per bruciatore - <i>Burner ventilation motor</i>	110	50	100
3.300.0012	Motore di ventilazione per bruciatore - <i>Burner ventilation motor</i>	415	50	100
3.300.0013	Motore di ventilazione per bruciatore - <i>Burner ventilation motor</i>	110	60	100
3.300.0014	Motore di ventilazione per bruciatore - <i>Burner ventilation motor</i>	230	50	150
3.300.0021	Motore di ventilazione per bruciatore - <i>Burner ventilation motor</i>	110	50	100
3.300.0022	Motore di ventilazione per bruciatore - <i>Burner ventilation motor</i>	200	50-60	
3.300.0023	Motore di ventilazione per bruciatore - <i>Burner ventilation motor</i>	230-240	50	100
3.300.0025	Motore di ventilazione per bruciatore - <i>Burner ventilation motor</i>	230	60	100

Voltaggio speciale - *Special voltage*

Strumentazione di controllo

Controls



Codice Code	Descrizione Description	Pressione Pressure		
		bar	psi	Mpa
6.008.0098	Kit per verifica pressione gasolio per caldaie <i>Testing kit for boilers fuel pressure</i>	0-12	0-174	0-1.2

Termostati e sensori di livello

Thermostats and level sensors



Codice Code	Descrizione Description	Temp. min.	Temp. max.	Attacco	Lunghezza	Cavo
		Min. temp.	Max. temp.	Connection	Length	Cable
		°C	°C	Ø mm	mm	mm
3.403.0032	Termostato <i>Thermostat</i>	30	90	6.5	---	---
3.403.0091	Termostato <i>Thermostat</i>	30	150	6.5	---	---
3.403.0078	Indicatore di livello gasolio <i>Fuel level indicator</i>	---	---	14	185	1300
3.403.0110	Indicatore di livello gasolio <i>Fuel level indicator</i>					
3.403.0127	Termoregolatore TLK38	0	200	---	---	---

Trasformatori di accensione Ignition transformers

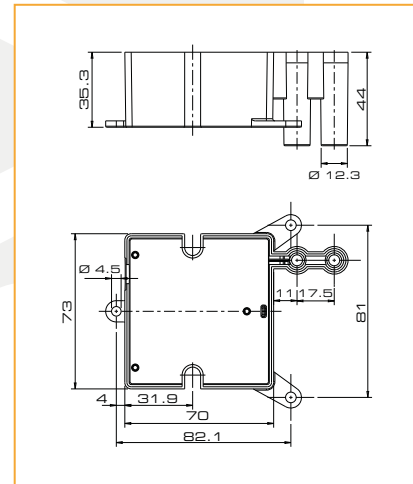

Voltaggio speciale - Special voltage

Codice Code	Descrizione Description	Tensione alimentazione Input voltage	Frequenza alimentazione Input frequency	Tensione uscita Output voltage	con cavo with cable	Elettrodi compatibili Suitable electrodes
		V	Hz	V		tipo - type
6.605.0102	Trasformatore di accensione 818 C/S COFI Ignition transformer 818 C/S COFI	230	50	2 x 4 kV	L = 900	B
3.400.0003	Trasformatore di accensione Ignition transformer	230	60	2 x 4 kV	L = 580	B
3.400.0004	Trasformatore di accensione Ignition transformer	230	50-60	2 x 4 kV	L = 580	B
3.400.0007	Trasformatore di accensione Ignition transformer	200	50-60	2 x 4 kV	L = 600	B
3.400.0019	Trasformatore di accensione COFI Ignition transformer COFI	120	60	2 x 4 kV	---	A
3.400.0022	Trasformatore di accensione COFI Ignition transformer COFI	200	50-60	2 x 12 kV	---	A
6.005.0157	Trasformatore di accensione TRK1 Ignition transformer TRK1	230-240	50-60	2 x 12 kV	L = 540	A
5.609.0126	Trasformatore di accensione con pipette NPX-LKX Ignition transformer with connectors NPX-LKX	230-240	50-60	2 x 12 kV	L = 500	B
5.009.0686	Trasformatore di accensione con pipette FKX Ignition transformer with connectors FKX	230-240	50-60	2 x 12 kV	L = 500	A

Elettrodi Electrodes

Codice Code	Descrizione Description
4.614.0003	Elettrodo D.2 Electrode D.2

Tipo A
Type A

Codice Code	Descrizione Description
4.614.0004	Coppia elettrodi unificati con staffa Couple of electrodes with bracket

Tipo B
Type B

Cavi ad alta tensione per elettrodi High voltage ignition cables for electrodes



Codice Code	Descrizione Description	Lunghezza cavo Cable length	Adatto per Suitable for
		mm	
5.611.0100	Cavo ad alta tensione con pipetta blu High voltage cable with blue connector	280	TRK1
5.611.0101	Cavo ad alta tensione con pipetta blu High voltage cable with blue connector	580	TRK1
5.611.0099	Cavo ad alta tensione con pipetta marrone High voltage cable with brown connector	480	Tutti i tipi All types
5.611.0097	Cavo ad alta tensione con pipetta marrone High voltage cable with brown connector	370	Tutti i tipi All types
5.611.0098	Cavo ad alta tensione con pipetta marrone High voltage cable with brown connector	580	Tutti i tipi All types
5.611.0077	Cavo ad alta tensione con pipetta blu High voltage cable with blue connector	280	COFI

Motori a scoppio e elettrici Combustion engines and electric motors

Motore a scoppio LAVORWASH

LAVORWASH engines



Codice Code	Sigla Sign	Tipo Type	Potenza Power		Cilindrata Displacement	Giri/min RPM	Alimentazione Fuel	Capacità serbatoio Fuel tank capacity	Colore Colour	Tipo attacco Coupling type
			Hp	kW						
3.600.0026	HP154	Monocilindrico 4 tempi raffreddato ad aria Aircooled 4-stroke single-cylinder	2,5	1,8	97	3600	Benzina senza piombo Unleaded fuel	1,5	Giallo Yellow	A
3.600.0029	HP154	Monocilindrico 4 tempi raffreddato ad aria Aircooled 4-stroke single-cylinder	2,5	1,8	97	3600	Benzina senza piombo Unleaded fuel	1,5	Nero Black	A
3.600.0027	HP168	Monocilindrico 4 tempi raffreddato ad aria Aircooled 4-stroke single-cylinder	5,5	4,1	163	3600	Benzina senza piombo Unleaded fuel	3,6	Giallo Yellow	A
3.600.0030	HP168	Monocilindrico 4 tempi raffreddato ad aria Aircooled 4-stroke single-cylinder	5,5	4,1	163	3600	Benzina senza piombo Unleaded fuel	3,6	Nero Black	A
3.600.0032	G200F	Monocilindrico 4 tempi raffreddato ad aria Aircooled 4-stroke single-cylinder	6,5	4,8	196	3600	Benzina senza piombo Unleaded fuel	3,6	Giallo Yellow	B
3.600.0034	G200F	Monocilindrico 4 tempi raffreddato ad aria Aircooled 4-stroke single-cylinder	6,5	4,8	196	3600	Benzina senza piombo Unleaded fuel	3,6	Nero Black	B
3.600.0031	G270F	Monocilindrico 4 tempi raffreddato ad aria Aircooled 4-stroke single-cylinder	9	6,7	270	3600	Benzina senza piombo Unleaded fuel	6	Grigio Grey	C
3.600.0035	G270F	Monocilindrico 4 tempi raffreddato ad aria Aircooled 4-stroke single-cylinder	9	6,7	270	3600	Benzina senza piombo Unleaded fuel	6	Nero Black	C

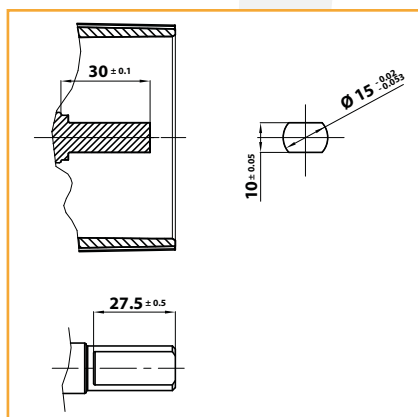

Attacco tipo **A**
Coupling type **A**

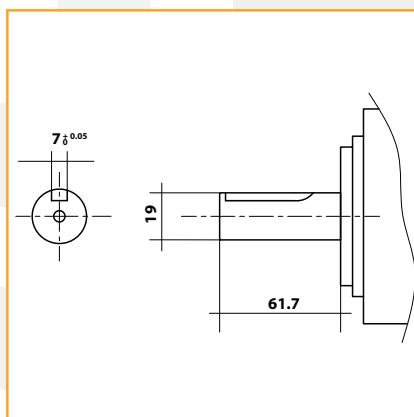

Attacco tipo **B**
Coupling type **B**

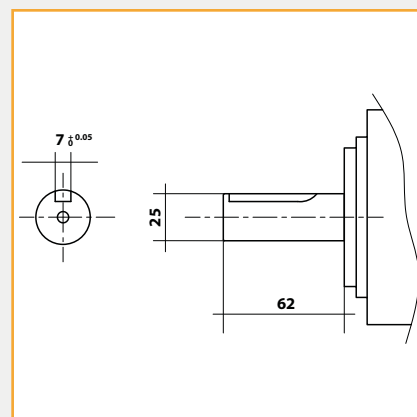

Attacco tipo **C**
Coupling type **C**

Motori elettrici raffreddati a liquido Liquid cooled electric motors



Codice Code	Tensione Voltage	Frequenza Frequency	Potenza Power	Poli Poles	Giri/min RPM	Cuscinetti Bearings
	V	Hz	Hp			
8.680.0059	400	50	5,5	4	1450	1 + 1
8.680.0060	400	50	7,5	4	1450	1 + 1
8.680.0061	400	50	10	4	1450	1 + 1
8.680.0062	400	60	7,5	4	1700	1 + 1
8.680.0063	400	60	9	4	1700	1 + 1

Voltaggio speciale - Special voltage

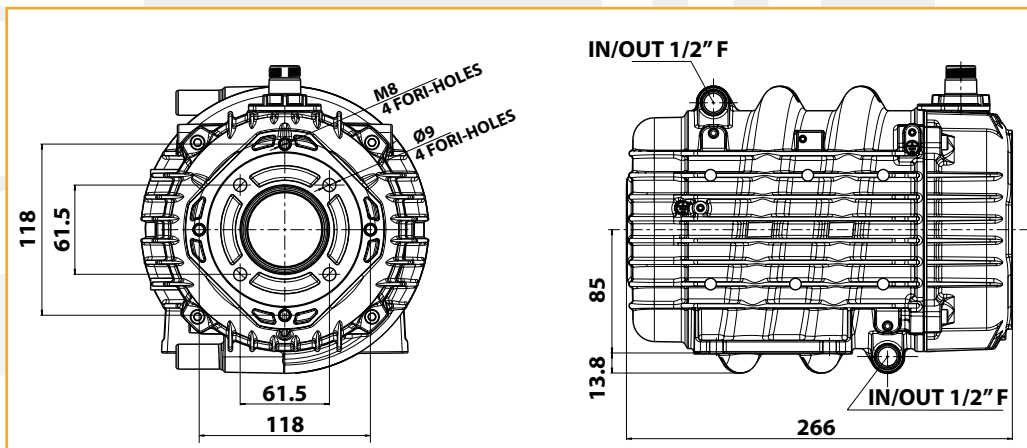

Flangiatura con giunto elastico per motori elettrici raffreddati a liquido Bell housing with flexible coupling for liquid cooled electric motors

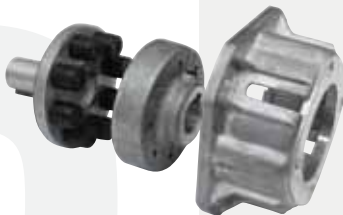

Codice Code	Centraggio pompa Pump coupling Ø	Albero Motore Ø Motor Shaft Ø	Albero Pompa Ø Pump Shaft Ø
	mm	mm	mm
6.605.0133	61	24 M	24 F
6.605.0134	90	24 M	24 F

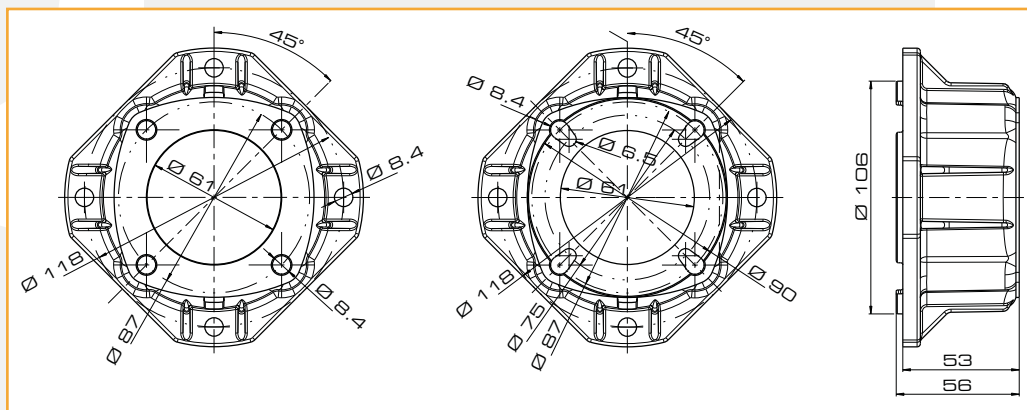

Motori elettrici raffreddati ad aria per montaggio diretto su pompe ad alta pressione

Air-cooled electric motors for direct coupling on high-pressure pumps



Codice Code	Tensione Voltage	Frequenza Frequency	Potenza Power	Poli Poles	Giri/min RPM	Cuscinetti Bearings
	V	Hz	Hp			
8.680.0064	230	50	3,5	4	1450	1
8.680.0066	400/415	50/60	4,5	4	1700	1
8.680.0067	220	60	3,5	4	1700	1
8.680.0065	240	50	3,5	4	1450	1

 Voltaggio speciale - Special voltage

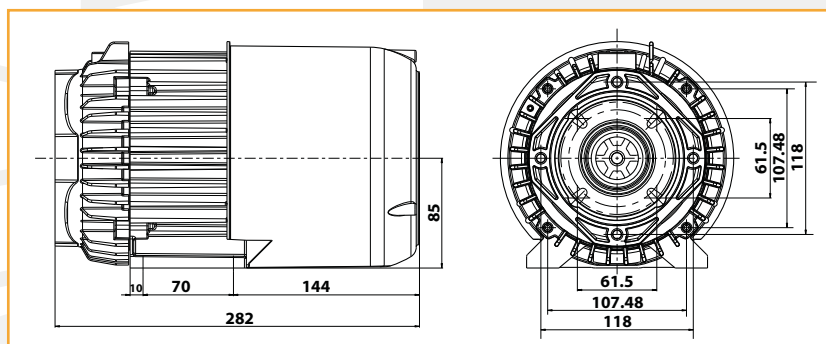

Motori elettrici raffreddati ad aria con giunto elastico

Air-cooled electric motors with flexible coupling



Codice Code	Tensione Voltage	Frequenza Frequency	Potenza assorbita Absorbed power	Poli Poles	Giri/min RPM	Cuscinetti Bearings
	V	Hz	Hp			
8.680.0068	230	50	3,5	4	1450	2
8.680.0070	400/415	50/60	4,5	4	1700	2
8.680.0071	220	60	3,5	4	1700	2
8.680.0069	240	50	3,5	4	1450	2

 Voltaggio speciale - Special voltage

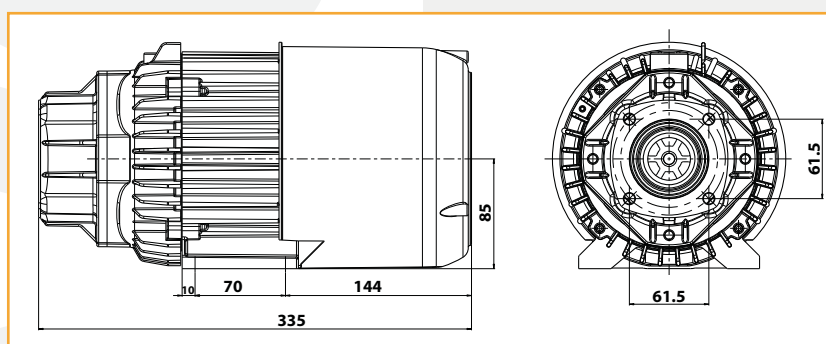

Pressostati

Pressure switches



Codice Code	Attacco Coupling	Pressione Pressure			Temperatura Temperature		Tensione max. Max. Voltage	Corrente max Max. current strength	Lunghezza cavo Cable length	Protezione elettrica Electrical insulation	Colore Colour
		bar	psi	MPa	°C	°F					
3.749.0454	G 3/8" M INOX	25	360	2,5	90	195	250	16	750	55 IP	Rosso Red
3.704.0005	G 1/4" M	45	650	4,5	90	195	250	6	750	55 IP	Nero Black
3.704.0006	G 1/8" M	25	360	2,5	90	195	250	6	750	55 IP	Rosso Red
3.704.0009	G 1/4" M	25	360	2,5	90	195	250	6	750	55 IP	Rosso Red
3.704.0013	G 1/8" M	10	145	1	90	195	250	6	200	55 IP	Giallo Yellow
3.704.0014	G 1/4" M	10	145	1	90	195	250	6	200	55 IP	Giallo Yellow

Flussostati

Flow switches



Codice Code	Entrata Inlet	Uscita Outlet	Pressione Pressure			Portata Flow rate		Temperatura Temperature		Lunghezza cavo Cable length	Protezione elettrica Electrical insulation
			bar	psi	MPa	l/m	GPM	°C	°F		
3.403.0002	G 3/8" M	G 3/8" M	250	3650	25	30	8	80	175	1250	55 IP

Teleruttori

Contactors



Codice Code	Descrizione Description	Tensione bobina Coil voltage	Tensione Voltage	Potenza Power	Modello Model
		V	V	Kw	
3.402.0001	Teleruttore KN12 Contactor KN12	24	400	5,5	GE/WIMEX/LAVOR
3.402.0002	Teleruttore KN22 Contactor KN22	24	400	11	GE/WIMEX/LAVOR
3.402.0009	Teleruttore G.E. Contactor G.E.	24	400	16	GE/SCHNEIDER/LAVOR
3.402.0011	Teleruttore ABB Contactor ABB	400	400	5,5	ABB
3.402.0050	Teleruttore KN12 Contactor KN12	400	400	5,5	GE/SCHNEIDER/LAVOR
3.402.0051	Teleruttore KN22 Contactor KN22	400	400	11	GE/SCHNEIDER/LAVOR
3.402.0052	Teleruttore KN12 Contactor KN12	230	230	5,5	GE/SCHNEIDER/LAVOR
3.402.0053	Teleruttore KN22 Contactor KN22	230	230	11	GE/SCHNEIDER/LAVOR

Relé termici

Thermal relays



Codice Code	Descrizione Description	Corrente Current	Tensione Voltage	Frequenza Frequency	Modello Model
		A	V	Hz	
3.402.0044	Relè termico DPER14 Thermal relay DPER14	7-10	400	50	TELEMECANIQUE-GE-LAVOR
3.402.0045	Relè termico DPER21 Thermal relay DPER21	12-18	400	50	TELEMECANIQUE-GE-LAVOR
3.402.0046	Relè termico DPER22 Thermal relay DPER22	16-24	400	50	TELEMECANIQUE-GE-LAVOR
3.402.0048	Relè termico DPER32 Thermal relay DPER32	23-32	400	50	TELEMECANIQUE-GE-LAVOR

Disgiuntori termici

Thermal breakers



Codice Code	Descrizione Description	Corrente Current	Tensione Voltage	Frequenza Frequency	Coperchio protezione Protecting cover	Modello Model	Cavo Cable
		A	V	Hz			
3.401.0004	ETA 3120-F554 -P7T1- W02F	16	230	50/60	X	E-T-A	-
3.401.0105	ETA 3120-F75N -P7T1- A20Q	18	230	50/60	X	E-T-A	-
3.401.0042	ETA 3120-F554 -P7T1- W02F	20	230	50/60	X	E-T-A	-
3.401.0043	ETA 3130-F160-P7T 1-387006	20	400	50/60	X	E-T-A	
3.401.0063	ETA 3140-F230 -P7TI- SGRX-3AC	16	400	50/60	X	E-T-A	-
3.401.0122	ETA 3140-F260 -P7TI- SGRX-3AC	18	400	50/60		E-T-A	
3.401.0049	MS 25 10/16	10-16	230/400	50/60	-	WIMEX-LAVOR	-
3.401.0050	MS 25 16/20	16-20	230/400	50/60	-	WIMEX-LAVOR	-
3.401.0051	MS 25 20/25	20-25	230/400	50/60	-	WIMEX-GE- LAVOR	-
3.401.0168	Termico cablato con spina Thermal breaker with cable and plug	10-16	230	50/60	X	WIMEX-LAVOR	3x1,5 / 5.5mt con spina Shuko with Shuko plug
3.401.0057	Termico cablato Thermal breaker with cable	10-16	400	50/60	X	WIMEX-LAVOR	H05 V V-F4x2,5 6 mt senza spina without plug
3.410.0018	Cassetta completa per termici - IP55 Complete case for thermal breakers - IP55					Adatta per Suitable for 3.401.0049 3.401.0050 3.401.0051	

Interruttori**Switches**

Codice Code	Descrizione Description	Corrente Current	Tensione Voltage	Frequenza Frequency	Modello Model
		A	V	Hz	
3.401.0106	Bipolare con spia <i>Bipolar with light</i>	16	230	50/60	MOLVENO
3.401.0178	ON/OFF 0/1 IP55	10-12	230	50/60	LAVOR
3.401.0179	ON/OFF 0/1 IP55	14-16	230	50/60	LAVOR
3.401.0177	ON/OFF 0/1 Verde/Rosso <i>ON/OFF 0/1 Green/Red</i>	10-12	230	50/60	LAVOR

**Adattatori da presa Shuko a UK con fusibile BS 1362****Adapters from Shuko to UK plug with fuse BS 1362**

Codice Code	Descrizione Description	Corrente Current	Tensione Voltage	Frequenza Frequency	Tipo Type
		A	V	Hz	
3.099.1361	Adattatore da presa Shuko a UK <i>Adapter from Shuko to UK plug</i>	10	240	50	senza terra <i>not grounded</i>
3.099.1360	Adattatore da presa Shuko a UK <i>Adapter from Shuko to UK plug</i>	13	240	50	con terra <i>grounded</i>

**Adattatore universale per presa Shuko****Universal adapter for Shuko plug**

Codice Code	Descrizione Description	Tipo Type	Corrente Current	Tensione Voltage	Frequenza Frequency
			A	V	Hz
3.099.0147	Adattatore universale presa Shuko <i>Universal Shuko plug adapter</i>	UK	10/13	240	50
		J	10/16	100	50/60
		USA	10/16	120	50/60
		AUS	10/16	240	50/60

**Condensatori****Capacitors**

Codice Code	Capacità Capacity	Tensione Voltage	Cavo Cable	Lunghezza cavo Cable length	Dimensioni Dimensions
	μ F	V		mm	\varnothing / L (mm)
3.404.0026	60	250	-	-	45/97
3.404.0002	80	250	-	-	45/123
3.404.0054	120	250	X	400	55/122
3.404.0067	16	450	-	-	35/70
3.404.0071	20	450	-	-	35/70
3.404.0017	25	450	-	-	39/94
3.404.0038	30	450	-	-	40/94
3.404.0016	45	450	-	-	45/93
3.404.0031	50	450	X	100	50/92
3.404.0007	65	450	X	100	50/120
3.404.0072	90	450	X	300	60/121
3.404.0075	50 - Electronic Xenon	130/480	-	-	50/120
3.404.0034	60 - Electronic Xenon	130/480	-	-	45/97



Schede di controllo e total stop

Control boards and total stop

Codice Code	Descrizione Description	Tensione alimentazione Input voltage	Frequenza alimentazione Input frequency	Potenza max. Max. Power	Tipo Type	Tensione uscita Output voltage
		V	Hz			V
3.403.0004	Scheda Total Stop TS1 <i>Total Stop board TS1</i>	24	50/60	---	Acqua calda <i>Hot water</i>	24
3.403.0012	Scheda elettrica <i>Electric board</i>	230	50/60	2000 W	Acqua calda e fredda <i>Hot and cold water</i>	230
3.403.0024	Scheda elettrica <i>Electric board</i>	240	50/60	2000 W	Acqua calda e fredda <i>Hot and cold water</i>	240
3.403.0034	Scheda elettrica ritardo gasolio <i>Electric board for diesel delay</i>	230	50/60	---	Acqua calda e fredda <i>Hot and cold water</i>	230
3.403.0068	Scheda elettrica ritardo gasolio <i>Electric board for diesel delay</i>	240	50/60	---	Acqua calda e fredda <i>Hot and cold water</i>	24
3.403.0085	Scheda elettrica ritardo Total Stop con controllo mancanza acqua <i>Total Stop delay electric board with water presence control</i>	24	50/60	---	Acqua fredda <i>Cold water</i>	24
3.403.0098	Scheda interruzione gasolio <i>Diesel stop/level board</i>	230	50/60	500 W	Acqua calda <i>Hot water</i>	230
3.403.0156	Scheda elettrica ritardo Total Stop <i>Total Stop delay electric board</i>	400	50/60	---	Acqua fredda <i>Cold water</i>	24
3.402.0012	Teleruttore TLR4FLW <i>Contacto TLR4FLW</i>	230/400	50/60	5,5 HP	Acqua fredda <i>Cold water</i>	24
3.402.0014	Teleruttore TLR6FLW <i>Contacto TLR 6FLW</i>	230/400	50/60	7,5 HP	Acqua fredda <i>Cold water</i>	24
3.402.0026	Teleruttore TLR4FC <i>Contacto TLR4FC</i>	230/400	50/60	5,5 HP	Acqua calda <i>Hot water</i>	24
3.402.0030	Teleruttore TLR6FC <i>Contacto TLR6FC</i>	230/400	50/60	7,5 HP	Acqua calda <i>Hot water</i>	24
3.402.0039	Teleruttore TLR10FC <i>Contacto TLR10FC</i>	230/400	50/60	10 HP	Acqua calda <i>Hot water</i>	24



Voltaggio speciale - Special voltage

Schemi elettrici e di collegamento disponibili su richiesta
Electric and connection diagrams available on request

Sistema di controllo e total stop completo TLR12 digitale

Complete control system and total stop TLR12 digital

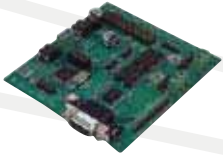

Codice Code	Descrizione Description	Tensione alimentazione Input voltage	Frequenza alimentazione Input frequency	Potenza max. Max. Power	Tipo Type	Tensione uscita Output voltage
		V	Hz			V
3.403.0102	Scheda elettronica con comandi	24	50/60	10 HP	Acqua calda Hot water	24
3.402.0013	Teleruttore TLR12DGT	230/400				
3.403.0037	Scheda elettronica con comandi professionale	24	50/60	10 HP	Acqua calda Hot water	24
3.402.0036	Teleruttore TLR12DGT professionale	440				

 Voltaggio speciale - Special voltage

Sistema di controllo e total stop completo TS2

Complete control system and total stop TS2



Codice Code	Descrizione Description	Tensione alimentazione Input voltage	Frequenza alimentazione Input frequency	Potenza max. Max. Power	Tipo Type	Tensione uscita Output voltage
		V	Hz			V
3.403.0171	Scheda Total Stop TS2 con stop automatico	230/400	50/60	---	Acqua calda Hot water	12-24
3.403.0194	Scheda Total Stop TS2 senza stop automatico					
3.403.0172	Scheda Led TS2	230/400	50/60	---	---	---
3.403.0181	Contaore per sistema TS2	---	---	---	---	---
7.701.1988	Adesivo per cruscotto TS2	---	---	---	---	---



3.403.0181



7.701.1988

Schemi elettrici e di collegamento disponibili su richiesta
Electric and connection diagrams available on request

VORWA

ASPIRATORI

VACUUM CLEANERS

SEERVO

ASPIRATORI VACUUM CLEANERS

ACCESSORI

- Filtri
- Tubi flessibili e raccordi
- Spazzole e lance
- Prolunghe
- Ruote
- Kit antistatici
- Kit accessori completi
- Accessori per lavaggio estrazione

RICAMBI

- Pompe detergente per aspiratori ad estrazione
- Interruttori
- Parti elettriche
- Motori di aspirazione universali
- Tubi per aspiratori industriali

ACCESSORIES

- *Filters* 116
- *Flexible hoses and couplings* 120
- *Brushes and lances* 122
- *Extension pipes* 123
- *Wheels* 124
- *Anti electrostatic current device kit* 124
- *Complete accessory kit* 125
- *Injection/extraction accessories* 126

SPARE PARTS

- *Detergent spraying pumps for injection/extraction vacuum cleaners* 127
- *Switches* 127
- *Electric components* 128
- *Universal vacuum motors* 129
- *Hoses for industrial vacuum cleaners* 131



Adatto a:

Suitable for:



GT



GN-GB



PRO 1 motore
PRO 1 motor



PRO 2/3 motori
PRO 2/3 motors

Filtri polveri in carta (per testata)

Paper filters for dusts (suitable for vacuum head)



Dimensioni (mm): Dimensions (mm):		Codice Kit 5 pz. Code Kit 5 pcs.	Codice Kit 10 pz. Code Kit 10 pcs.
Largh. (W)	Alt. (H)		
180	320	5.212.0002 EAN 8013298100057	5.212.0005 EAN 801329810493



Codice / Code 3.752.0007
Elastico per sacchetti
Elastic for paper bags

Filtri polveri in carta a cartuccia (per testata)

Paper cartridge filters for dusts (suitable for vacuum head)



Codice Code	Tipo Type	Ø esterno Outer Ø	Ø interno Inner Ø	Altezza Height	In scatola Boxed	Codice EAN EAN code	Adatto a: Suitable for:
		mm	mm	mm	Codice/Code		
3.752.0041	Filtro in carta aperto 7 micron - sfuso Paper opened filter 7 micron - unpacked	175	154	137	5.212.0006	8013298010503	
3.752.0187	Filtro in carta aperto 7 micron - sfuso Paper opened filter 7 micron - unpacked	123	86	104	5.212.0029	8013298100330	
3.752.0093	Filtro in carta chiuso - 7 micron - sfuso Paper closed filter 7 micron - unpacked	170	128	96	---	---	Whisper/Silent
3.752.0085	Filtro in carta chiuso - 7 micron - sfuso Paper closed filter 7 micron - unpacked	175	152	146	---	---	Sahara/Alpha

Filtri Hepa a cartuccia per polveri sottili (per testata)

Hepa cartridge filters for fine dusts (suitable for vacuum head)





Codice Code	Tipo Type	Ø esterno Outer Ø	Ø interno Inner Ø	Altezza Height	In scatola Boxed	Codice EAN EAN code	Adatto a: Suitable for:
		mm	mm	mm	Codice/Code		
3.752.0194	Hepa aperto 0.3 micron - sfuso Hepa opened 0.3 micron - unpacked	270	220	280	5.212.0034	8013298100378	
3.752.0195	Hepa aperto 0.3 micron - sfuso Hepa opened 0.3 micron - unpacked	123	86	104	5.212.0037	8013298100385	
3.752.0046	Hepa aperto 0.3 micron - sfuso Hepa opened 0.3 micron - unpacked	175	154	137	5.212.0010	8013298100064	
3.752.0092	Hepa chiuso 0.3 micron - sfuso Hepa closed 0.3 micron - unpacked	170	128	96	---	---	Whisper/Silent
3.752.0086	Hepa chiuso 0.3 micron - sfuso Hepa closed 0.3 micron - unpacked	175	148	144	---	---	Sahara/Alpha

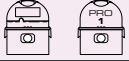

Filtri lavabili a cartuccia per polveri standard e sottili (per testata)

Washable cartridge filters for standard and fine dusts (suitable for vacuum head)

Codice Code	Tipo Type	Ø esterno Outer Ø	Ø interno Inner Ø	Altezza Height	In scatola Boxed	Codice EAN EAN code	Adatto a: Suitable for:
		mm	mm	mm	Codice/Code		
3.752.0073	Lavabile 5 micron - sfuso Washable 5 micron - unpacked	175	154	137	5.212.0020	8013298100101	
3.752.0196	Lavabile 5 micron - sfuso Washable 5 micron - unpacked	123	86	104	5.212.0040	8013298100408	
3.752.0082	Lavabile 5 micron - sfuso Washable 5 micron - unpacked	270	220	280	5.212.0021	8013298100262	

Filtri in panno per polveri (per testata)

Cloth filters for dusts (suitable for vacuum head)

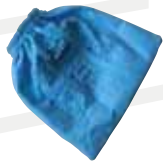



Codice Code	Tipo Type	Diametro elastico Elastic diameter	Altezza Height	In scatola Boxed	Codice EAN EAN code	Adatto a: Suitable for:
		mm	mm	Codice/Code		
3.752.0237	Filtro in panno - sfuso Cloth filter - unpacked	135-175	250	5.212.0101	8013298101030	 

Filtri in nylon per polveri sottili (per testata)

Nylon filters for fine dusts (suitable for vacuum head)



Codice Code	Tipo Type	Diametro elastico Elastic diameter	Altezza Height	In scatola Boxed	Codice EAN EAN code	Adatto a: Suitable for:
		mm	mm	Codice/Code		
3.752.0182	Filtro in nylon - sfuso Nylon filter - unpacked	350-450	360	5.212.0093	8013298100941	
3.752.0155	Filtro in nylon - sfuso Nylon filter - unpacked	135-160	240	5.212.0094	8013298100958	

Filtri in spugna per liquidi (per testata)

Foam filters for liquids (suitable for vacuum head)



Codice Code	Tipo Type	Diametro Diameter	Altezza Height	In scatola Boxed	Codice EAN EAN code	Adatto a: Suitable for:
		mm	mm	Codice/Code		
3.752.0032	Filtro in spugna - sfuso Foam filter - unpacked	120	140	6.205.0011	8013298100149	 
In scatola Boxed	Filtro in spugna - sfuso Foam filter - unpacked	80	110	5.212.0030	8013298100347	
3.752.0172	Filtro in spugna - sfuso Foam filter - unpacked	128	150	---		Sahara/Alpha

Filtri raccoglitori in carta per polveri con valvola (per fusto)

Paper collector filters for dusts with valve (suitable for vacuum cleaner tank)

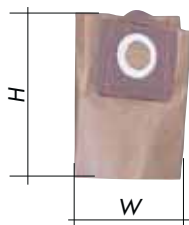

Codice Code	Dimensioni (mm): Dimensions (mm):			Codice Kit 5 pz. Code Kit 5 pcs.	Codice Kit 10 pz. Code Kit 10 pcs.	Adatto a: Suitable for:
	Largh. (W)	Alt. (H)	Ø valvola Valve Ø			
In kit	450	300	64	5.212.0007 EAN 8013298100040	---	
In kit	550	250	68	5.212.0016 EAN 8013298010547	---	
In kit	140	105	45	---	6.205.0040 EAN 8013298100255	Universale Universal
In kit	350	640	56	---	5.212.0022 EAN 8013298100279	
In kit	550	200	56	---	5.212.0023 EAN 8013298100286	Whisper/Silent Sahara/Alpha
In kit	550	250	56	5.212.0031 EAN 8013298100354	---	Universale/ Universal Energy
In kit	300	550	68	5.212.0049 EAN 8013298100514	---	

Filtri per polveri speciali/pericolose con valvola (per fusto)

Filters for special/dangerous dusts (suitable for vacuum cleaner tank)

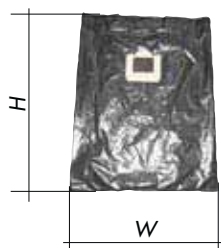

Codice Code	Dimensioni (mm): Dimensions (mm):			Codice Kit 5 pz. Code Kit 5 pcs.	Codice Kit 10 pz. Code Kit 10 pcs.	Adatto a: Suitable for:
	Largh. (W)	Alt. (H)	Ø attacco Coupling Ø			
3.752.0202	320	720	64	---	5.212.0048 EAN 8013298100507	 ESM ESH

Filtri in panno per polveri (per fusto)

Cloth filters for dusts (suitable for vacuum cleaner tank)



Codice Code	Tipo Type	Diametro	Altezza	In scatola Boxed	Codice EAN EAN code	Adatto a: Suitable for:
		Diameter	Height			
5.209.0052	Filtro in panno - sfuso Cloth filter - unpacked	355-360	270	6.205.0008	8013298100118	
5.509.0039	Filtro in panno - sfuso Cloth filter - unpacked	410-420	400	---	---	
5.209.0009	Filtro in panno - sfuso Cloth filter - unpacked	300-305	235	5.212.0043	8013298100422	

Filtri in panno/nylon per polveri sottili (per fusto)

Cloth/nylon filters for fine dusts (suitable for vacuum cleaner tank)

Codice Code	Tipo Type	Diametro	Altezza	In scatola Boxed	Codice EAN EAN code	Adatto a: Suitable for:
		Diameter	Height			
5.209.0020	Filtro in nylon - sfuso Nylon filter - unpacked	300-305	340	5.212.0092	8013298100934	
5.509.1405	Filtro in panno - sfuso Cloth filter - unpacked	410-420	400	---	---	

Filtri lavabili a cartuccia per ceneri (per testata)*Washable cartridge filters for ashes (suitable for vacuum head)*

Codice Code	Tipo Type	Ø esterno Outer Ø	Ø interno Inner Ø	Altezza Height	In scatola Boxed	Codice EAN EAN code	Adatto a: Suitable for:
		mm	mm	mm	Codice/Code		
3.752.0224	Lavabile per ceneri - sfuso <i>Washable for ashes - unpacked</i>	174	150-152	150	5.212.0054	8013298100552	Ashley 100 Ashley 300
3.752.0199	Lavabile per ceneri - sfuso <i>Washable for ashes - unpacked</i>	123	87-89	105	5.212.0047	8013298100491	Ashley 800 1000 Evo Double
3.752.0233	Lavabile chiuso per ceneri - sfuso <i>Washable closed filter for ashes - unpacked</i>	135	111-113	102	5.212.0090	8013298100910	Ashley 200-310 Riù

NEW**Filtri in panno lavabili "doppio filtraggio" per ceneri (per testata) (*)***Washable "double filtering" cloth filters for ashes (suitable for vacuum head) (*)*

Codice Code	Tipo Type	Diametro Diameter	Altezza Height	In scatola Boxed	Codice EAN EAN code	Adatto a: Suitable for:
		mm	mm	Codice/Code		
3.752.0238	Filtro in panno per ceneri - sfuso <i>Cloth filter for ashes - unpacked</i>	135-160	240	5.212.0096	8013298100972	Ashley 200-300 310-800-1000 Evo-Double / Riù
3.752.0240	Filtro in panno per ceneri - sfuso <i>Cloth filter for ashes - unpacked</i>	148-175	250	5.212.0095	8013298100965	Ashley Plus

(*) da utilizzare solo in combinazione con il filtro a cartuccia

(*) to be used only in combination with the cartridge filter

Kit di conversione da aspiratore ad aspiracenere*Conversion kit vacuum cleaner to ash vacuum cleaner***NEW**

Codice Code	Tipo Type	Diametro Diameter	Codice EAN EAN code	Adatto a: Suitable for:
		mm		
5.212.0097	Kit conversione per aspiratori serie GN/GB Lavor <i>Conversion kit for GN/GB Lavor vacuum cleaners</i>	154-158	8013298100989	
5.212.0098	Kit conversione per aspiratori serie GT Lavor <i>Conversion kit for GT Lavor vacuum cleaners</i>	86-90	8013298100996	

**Detergente per vetri o griglie di stufe e caminetti - 0,75 l***Cleaner for glass or grids of stoves and fireplaces - 0,75 l*Codice - Code
6.009.0098**NEW**

Tubi flessibili di aspirazione - diametro 35 mm

Flexible suction hoses - 35 mm diameter



Codice Code	Tipo Type	Lunghezza Length	Diametro Diameter	Colore Colour	Kit completo Complete kit	Codice EAN EAN code	Adatto a: Suitable for:
		mt	mm		Codice/Code		
3.753.0063	Matassa tubo flex Roll of flexible hose	30	35	Nero Black	---		
---	Tubo flex completo Complete flexible hose	2	35	Nero Black	6.205.0014		
---	Tubo flex completo Complete flexible hose	4	35	Nero Black	6.205.0017	8013298100200	
---	Tubo flex completo Complete flexible hose	5	35	Nero Black	5.209.0100		

Tubi flessibili di aspirazione - diametro 40 mm

Flexible suction hoses - 40 mm diameter

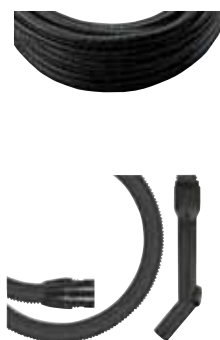

Codice Code	Tipo Type	Lunghezza Length	Diametro Diameter	Colore Colour	Kit completo Complete kit	Adatto a: Suitable for:
		mt	mm		Codice/Code	
3.753.0038	Matassa tubo Roll of flexible hose	30	40	Nero Black	---	
---	Tubo flex completo impugnatura curva Flexible hose complete with curved handle	2,5	40	Nero Black	5.209.0102	
---	Tubo flex completo impugnatura diritta Flexible hose complete with straight handle	2,5	40	Nero Black	5.209.0021	
---	Tubo flex completo Complete flexible hose	4	40	Nero Black	5.209.0127	
---	Tubo flex completo Complete flexible hose	5	40	Nero Black	5.209.0082	
---	Tubo flex completo Complete flexible hose	10	40	Nero Black	5.209.0083	

Raccordi per tubi di aspirazione - diametro 35 mm

Couplings for flexible suction hoses - 35 mm diameter



Codice Code	Tipo Type	Diametro Diameter	A	Kit completo Complete kit	Codice EAN EAN code	Adatto a: Suitable for:
		mm	mm	Codice/Code		
4.208.0067	Innesto con tasto - lato fusto Tank sleeve with button	35	58	6.205.0118 Kit innesti Sleeve kit	---	
3.752.0026	Innesto con baionetta - lato fusto Bayonet tank sleeve	35	58	6.205.0124 Kit raccordi Couplings kit	---	
3.752.0028	Raccordo dritto girevole - lato accessori Swivel straight coupling - accessories side	35	Universale Universal			
3.753.0077	Raccordo curvo girevole Swivel curved coupling	35	Universale Universal	5.212.0044 Kit raccordi per elettroutensili Kit couplings for power tools	8013298100439	
4.208.0063	Raccordo per elettroutensili Coupling for power tools	27-35	Universale Universal			

Raccordi per tubi di aspirazione - diametro 40 mm*Couplings for flexible suction hoses - 40 mm diameter*



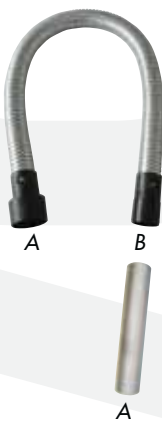



















Codice Code	Tipo Type	Diametro Diameter	A	Kit completo Complete kit	Codice EAN EAN code	Adatto a: Suitable for:
		mm	mm	Codice/Code		
3.753.0086	Raccordo curvo girevole <i>Swivel curved coupling</i>	40	Universale <i>Universal</i>	---		
3.754.0208	Manicotto conduttivo - lato accessori <i>Conductive coupling - tool side</i>	40	Universale <i>Universal</i>	---		
3.754.0209	Manicotto conduttivo - lato fusto <i>Conductive coupling - tank side</i>	40	Universale <i>Universal</i>	---		
3.752.0118	Manicotto dritto <i>Straight sleeve</i>	40	Universale <i>Universal</i>	6.205.0124 Kit manicotti <i>Sleeve kit</i>		
4.208.0063	Raccordo per elettrotensili - 27-35 mm <i>Coupling for power tools - 27-35 mm</i>	27-35	Universale <i>Universal</i>	5.212.0044 Kit raccordi per elettrotensili <i>Kit couplings for power tools</i>	8013298100439	
3.754.0046	Manicotto - lato accessori - D.40-40 <i>Sleeve - tool side - D.40-40</i>	40	Universale <i>Universal</i>	6.205.0122 Kit manicotti <i>Sleeve kit</i>		
3.754.0047	Manicotto - lato fusto - D.40-40 <i>Sleeve - tank side - D.40-40</i>	40	Universale <i>Universal</i>			
3.752.0075	Bocchetta lato fusto ad innesto rapido <i>Quick coupling tank sleeve</i>	40	---	6.205.0071 Kit bocchetta + guarnizione <i>Kit sleeve + gasket</i>		
3.099.0455	Guarnizione per bocchetta ad innesto rapido <i>Gasket for quick coupling tank sleeve</i>	---	---			

Tubi flessibili in metallo per aspiraceneri*Metal flexible hoses for ash vacuum cleaners*

Codice Code	Tipo Type	Lunghezza Length	Diametro A Diameter A	Diametro B Diameter B	Kit completo Complete kit	Adatto a: Suitable for:
		mt	mm	mm	Codice/Code	
3.753.0083C	Tubo acciaio per ceneri - 1 mt <i>Steel flexible hose for ash suction - 1 mt</i>	1	57-58	40	6.205.0099 Tubo flex acciaio per ceneri completo <i>Complete steel flexible hose for ash suction</i>	Ashley
3.753.0102C	Tubo acciaio per ceneri - 1,5 mt <i>Steel flexible hose for ash suction - 1,5 mt</i>	1.5	57-58	40	---	
3.753.0100	Tubo acciaio per ceneri - 2 mt <i>Steel flexible hose for ash suction - 2 mt</i>	2	57-58	40	---	
3.752.0171C	Lancia per cenere <i>Suction lance for ashes</i>	0.20	40	40	---	

Spazzole e lance per polveri e liquidi - diametro 35 mm

Brushes and lances for dusts and liquids - 35 mm diameter

Codice Code	Tipo Type	Diametro Diameter	Lunghezza Length	Kit completo Complete kit	Codice EAN EAN code	Adatto a: Suitable for:
		mm	mm	Codice/Code		
 3.754.0005	Lancia piatta Flat lance	35	210	---	---	
 3.754.0004	Spazzola piccola per polveri Small brush	35	150	---	---	
 3.754.0015	Spazzola tonda con setole in nylon Round brush with nylon bristles	35	120	---	---	
 3.754.0217	Spazzola tonda con setole in acciaio inox Round brush with S/S bristles	35	120	5.211.0066 Spazzola tonda con adattatore universale Round brush with universal adapter	---	
 3.754.0204	Spazzola tonda inclinata con setole in crine nero Folded round brush with black horsehair bristles	35	120	---	---	
 3.754.0118	Spazzola tonda inclinata con setole in crine marrone Folded round brush with brown horsehair bristles	35	120	6.405.0085 Spazzola tonda angolabile completa Folded round brush complete	---	
 3.754.0018	Spazzola per caloriferi Brush for radiators	35	115	---	---	
 3.754.0014	Spazzola rettangolare nera per polveri/tappeti Rectangular combined brush floor/carpet - black	35	250	---	---	
 3.754.0016	Spazzola rettangolare cromata per polveri/tappeti Rectangular combined brush floor/carpet - chrome plated	35	250	6.205.0096 Spazzola rettangolare completa Rectangular brush complete	8013298100477	
 3.754.0081	Spazzola Turbo Brush rotante automatica - grande Automatically rotating Turbo Brush - large	35	270	---	---	
 3.754.0080	Spazzola Turbo Brush rotante automatica - piccola Automatically rotating Turbo Brush - small	35	140	---	---	
 3.754.0188	Corpo portaccessori 35 mm - L=250 mm Accessory holder 35 mm - L=250 mm	35	250	6.205.0117 Spazzola completa per polveri e liquidi Wet&Dry complete brush	---	
 3.754.0191	Accessorio polveri/liquidi 35 mm - L=250 mm Wet & Dry accessory 35 mm - L=250 mm	35	250			
 3.754.0190	Accessorio liquidi 35 mm - L=250 mm Wet accessory 35 mm - L=250 mm	35	250			
 3.754.0189	Accessorio polveri setolato 35 mm - L=250 mm Brushed floor accessory 35 mm - L=250 mm	35	250			
 3.754.0168	Corpo portaccessori 35 mm - L=300 mm Accessory holder 35 mm - L=300 mm	35	300	6.205.0125 Spazzola completa per polveri e liquidi Wet&Dry complete brush	---	
 3.754.0169	Accessorio polveri setolato 35 mm - L=300 mm Brushed floor accessory 35 mm - L=300 mm	35	300			
 3.754.0170	Accessorio liquidi 35 mm - L=300 mm Wet accessory 35 mm - L=300 mm	35	300			
 3.754.0171	Accessorio tappeti 35 mm - L=300 mm Carpet accessory 35 mm - L=300 mm	35	300			

Spazzole e lance per polveri e liquidi - diametro 37-40 mm

Brushes and lances for dusts and liquids - 37-40 mm diameter



Codice Code	Tipo Type	Diametro Diameter	Lunghezza Length	Kit completo Complete kit	Adatto a: Suitable for
		mm	mm	Codice/Code	
3.754.0049	Spazzola tonda con setole in nylon Round brush with nylon bristles	40	120	---	
3.754.0048	Lancia piatta Flat lance	40	210	---	
3.754.0200	Corpo portaccessori Accessory holder	40	300	---	
3.754.0201	Corpo portaccessori Accessory holder	40	400	---	
3.754.0185	Corpo portaccessori Accessory holder	37	300	6.205.0120 Spazzola completa per polveri e liquidi Wet&Dry complete brush	
3.754.0169	Accessorio polveri setolato Brushed floor accessory	37-40	300		
3.754.0170	Accessorio liquidi Wet accessory	37-40	300		
3.754.0171	Accessorio tappeti Carpet accessory	37-40	300	6.205.0121 Spazzola completa per polveri e liquidi Wet&Dry complete brush	
3.754.0083	Corpo portaccessori Accessory holder	37	400		
3.754.0084	Accessorio polveri setolato Brushed floor accessory	37-40	400		
3.754.0085	Accessorio liquidi Wet accessory	37-40	400		
3.754.0086	Accessorio tappeti Carpet accessory	37-40	400		

Prolunghe - diametro 35 mm

Extension pipes - 35 mm diameter

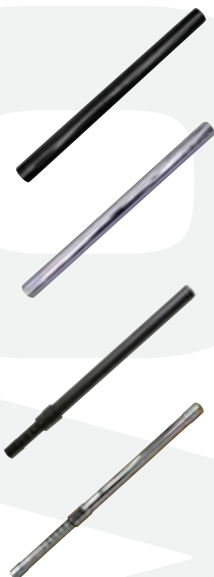

Codice Code	Tipo Type	Diametro Diameter	Lunghezza Length	Kit completo Complete kit	Codice EAN EAN code	Adatto a: Suitable for:
		mm	mm	Codice/Code		
3.753.0072	Prolunga dritta in plastica liscia Plastic extension pipe	35	450	---	---	
3.753.0002	Prolunga dritta in plastica rigata Lined plastic extension pipe	35	450	---	---	
3.753.0094	Prolunga dritta in plastica trasparente Transparent plastic extension pipe	35	450	---	---	
3.753.0009	Prolunga dritta in acciaio cromato Chrome plated steel extension pipe	35	490	6.205.0109 Prolunga acciaio cromato 37mm- L=490mm Chrome plated steel extension pipe 37mm-L=490mm	8013298100521	
3.753.0084	Prolunga telescopica in plastica Plastic telescopic extension pipe	35	570-1000	6.205.0097 Prolunga telescopica in plastica 37mm-L=570-1000mm Plastic telescopic extension pipe 37mm-L=570-1000mm	8013298100484	
3.753.0103	Prolunga telescopica in acciaio cromato Chrome plated steel telescopic extension pipe	35	570-1000	---	---	

Prolunghe - diametro 37-40 mm

Extension pipes - 37-40 mm diameter

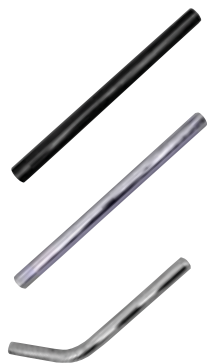

Codice Code	Tipo Type	Diametro Diameter	Lunghezza Length	Kit completo Complete kit	Codice EAN EAN code	Adatto a: Suitable for:
		mm	mm	Codice/Code		
3.753.0039	Prolunga dritta in plastica Plastic extension pipe	40	500	---	---	
3.753.0009	Prolunga dritta in acciaio cromato Chrome plated steel extension pipe	37	500	6.205.0109 Prolunga acciaio cromato 37mm-L=490mm Chrome plated steel extension pipe 37mm-L=490mm	8013298100521	
3.753.0110	Prolunga dritta in acciaio cromato Chrome plated steel extension pipe	37	640	6.205.0126 Kit tubo acciaio cromato dritto+curvo 40mm Kit chrome plated steel straigh+curved pipe 40mm	---	
3.753.0109	Prolunga curva in acciaio cromato Chrome plated steel curved extension pipe	37	670			

Ruote Wheels



Codice Code	Tipo Type	Diametro Diameter	Attacco Connection	Colore Colour	Adatto a: Suitable for:
		mm	Ø mm		
3.754.0006	Ruota pivotante nera Pivoting wheel - black	39	12-12.5	Nero Black	
3.754.0041	Ruota pivotante grigia Pivoting wheel - grey	39	12-12.5	Grigio Grey	
3.754.0199	Ruota pivotante nera Pivoting wheel - black	40	12-12.5	Nero Black	
3.754.0017	Ruota pivotante nera Pivoting wheel - black	50	12-12.5	Grigio Grey	

Kit antistatici



Anti electrostatic current device kit



Codice Code	Tipo Type	Codice EAN EAN code	Adatto a: Suitable for:
6.205.0043	Kit antistatico per aspiratori Hobby Anti electrostatic current device kit for Hobby vacuum cleaners	8013298100293	
6.205.0114	Kit antistatico per aspiratori Pro con un motore Anti electrostatic current device kit for Pro vacuum cleaners with one motor	---	
6.205.0074	Kit antistatico per aspiratori Pro con due e tre motori Anti electrostatic current device kit for Pro vacuum cleaners with two and three motor	---	



Kit accessori completi - diametro 35 mm

Complete accessory kits - 35 mm diameter

Codice Code	Tipo Type	Diametro Diameter	Composizione Kit Kit composition	Adatto a: Suitable for:
		mm		
6.205.0116	Kit prolunghe e accessori di base - Spazzole-Lance <i>Kit extensions pipes and basic accessories - Brushes-Lances</i>	35	A: 3.753.0002 B: 3.754.0018 C: 3.754.0005 D: 3.754.0004 E: 3.754.0015 F: 4.208.0063	
6.205.0117	Kit spazzola polveri/liquidi completa <i>Kit floor/wet brush complete</i>	35	G: 3.754.0188 H: 3.754.0191 I: 3.754.0189 L: 3.754.0190	
6.005.0118	Kit bocchette/raccordi <i>Kit sleeves/couplings</i>	35	M: 4.208.0067 N: 3.752.0026 O: 3.753.0077	

Kit accessori completi - diametro 37-40 mm

Complete accessory kits - 37-40 mm diameter

Codice Code	Tipo Type	Diametro Diameter	Composizione Kit Kit composition	Adatto a: Suitable for:
		mm		
6.205.0123	Kit prolunghe e accessori di base - Spazzole-Lance <i>Kit extensions pipes and basic accessories - Brushes-Lances</i>	37	C: 3.754.0005 D: 3.754.0004 E: 3.754.0015	
6.005.0119	Kit prolunghe e accessori di base - Spazzole-Lance <i>Kit extensions pipes and basic accessories - Brushes-Lances</i>	40	A: 3.753.0039 C: 3.754.0048 E: 3.754.0049	
6.205.0124	Kit bocchette/raccordi <i>Kit sleeves/couplings</i>	37	M: 3.752.0118 N: 3.752.0028 O: 3.753.0077	
6.205.0122	Kit bocchette/raccordi <i>Kit sleeves/couplings</i>	40	M: 3.754.0047 N: 3.754.0046	
6.205.0125	Kit spazzola polveri/liquidi completa <i>Kit floor/wet brush complete</i>	37	G: 3.754.0168 H: 3.754.0169 I: 3.754.0171 L: 3.754.0170	
6.205.0120	Kit spazzola polveri/liquidi completa <i>Kit floor/wet brush complete</i>	40	G: 3.754.0185 H: 3.754.0169 I: 3.754.0171 L: 3.754.0170	
6.205.0121	Kit spazzola polveri/liquidi completa <i>Kit floor/wet brush complete</i>	40	G: 3.754.0083 H: 3.754.0084 I: 3.754.0086 L: 3.754.0085	
6.205.0126	Kit tubo acciaio cromato dritto + curvo <i>Kit chrome plated steel straight+curved extension pipe</i>	40	P: 3.753.0110 Q: 3.753.0109	
0.110.0062	Squeegee completo per aspiratori <i>Complete squeegee for vacuum cleaners</i>	40	R	
0.911.0210	Lama anteriore squeegee di ricambio <i>Replacement front squeegee blade</i>	---	---	
0.911.0211	Lama posteriore squeegee di ricambio <i>Replacement rear squeegee blade</i>	---	---	
0.110.0020	Kit dispositivo antischiuma per aspiratori <i>Kit antifoam device for vacuum cleaners</i>	40	S	



R



S

Lavaggio ad estrazione - diametro 35 mm

Injection - Extraction - 35 mm diameter



Codice Code	Tipo Type	Diametro Diameter	Colore Colour	Rif. foto Photo ref.	Adatto a: Suitable for:
		mm			
5.211.0038	Kit tubo flex completo di agganci e tubo detergente - 2 mt <i>Kit flexible hose complete with couplings and detergent hose 2 mt.</i>	35	Nero Black	A	
3.752.0176	Rubinetto erogatore <i>Dispenser tap</i>	---	Nero Black	B	
5.209.0093	Bocchetta grande per pavimento completa di squeegee <i>Large floor tool complete with squeegee</i>	35	Trasparente Transparent	C	
5.211.0024	Slitta completa di squeegee per bocchetta grande <i>Chassis complete with squeegee for large floor tool</i>	---	Trasparente Transparent	D	
4.208.0234	Gomma squeegee di ricambio <i>Replacement squeegee blade</i>	---	Nero Black	D	
3.752.0165	Spruzzatore completo di ugello <i>Sprayer complete with nozzle</i>	---	Nero Black	E	
3.752.0163	Ugello erogatore di ricambio <i>Replacement nozzle</i>	---	Rosso Red	F	
3.099.0705	Tubo Elastoflex 8X1 Sh.98 per prodotto chimico <i>Elastoflex hose 8X1 Sh.98 for chemical products</i>	---	Nero Black	G	
4.208.0235	Clip di ricambio fissaggio tubo detergente <i>Replacement fixing clip for detergent hose</i>	35	Nero Black	H	

Lavaggio ad estrazione - diametro 37-40 mm

Injection - Extraction - 37-40 mm diameter



Codice Code	Tipo Type	Diametro Diameter	Colore Colour	Rif. foto Photo ref.	Adatto a: Suitable for:
		mm			
6.205.0132	Kit lavaggio/estrazione per tappeti con prolunghe, bocchette e raccordi <i>Kit carpet cleaning with extension pipes, tools and sleeves</i>	37-40	Nero Black	I	
6.205.0129	Kit tubo flex completo di agganci e tubo detergente - 2,5 mt <i>Kit flexible hose complete with couplings and detergent hose 2,5 mt.</i>	37-40	Nero Black	A	
6.205.0130	Kit tubo flex completo di agganci e tubo detergente - 5 mt <i>Kit flexible hose complete with couplings and detergent hose 5 mt.</i>	37-40	Nero Black	A	
6.205.0131	Kit tubo flex completo di agganci e tubo detergente - 10 mt <i>Kit flexible hose complete with couplings and detergent hose 10 mt.</i>	37-40	Nero Black	A	
5.209.0143	Bocchetta piccola poltrone/sedili completa di erogatore <i>Small armchair tool complete with dispenser</i>	37-40	Trasparente Transparent	L	
5.209.0050	Bocchetta grande per pavimenti completa di erogatore <i>Large floor tool complete with dispenser</i>	37-40	Trasparente Transparent	C	
3.752.0098	Erogatore di ricambio per bocchetta piccola <i>Replacement dispenser for small tool</i>	---	Nero Black	M	
3.752.0101	Erogatore per bocchetta grande <i>Dispenser for large tool</i>	---	Nero Black	B	
5.211.0076	Rubinetto completo con anello di fissaggio <i>Complete tap with fixing ring</i>	---	Nero Black	N	
3.752.0097	Ugello erogatore di ricambio <i>Replacement nozzle</i>	---	Rosso Red	F	
3.099.1375	Clip di ricambio fissaggio tubo detergente <i>Replacement fixing clip for detergent hose</i>	37-40	Nero Black	H	
3.752.0124	Innesto rapido in acciaio inox - femmina <i>Quick female stainless steel coupling</i>	---	Inox Stainless Steel	O	
3.752.0128	Innesto rapido in acciaio inox - maschio <i>Quick male stainless steel coupling</i>	---	Inox Stainless Steel	P	

Parti di ricambio per aspiratori Spare parts for vacuum cleaners

Pompe detergente per aspiratori ad estrazione

Detergent spraying pumps for injection/extraction vacuum cleaners

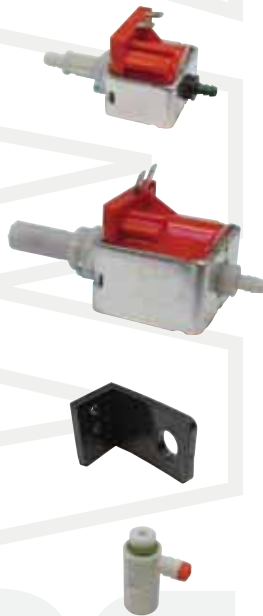

Codice Code	Tipo Type	Tensione Voltage	Frequenza Frequency	Pressione Pressure			Portata Flow rate
				bar	psi	Mpa	
		V	Hz				cc/min
3.551.0032	Pompa per detergente ULKA NME 1C Detergent spraying pump ULKA NME 1C	230-240	50-60	2	29	0.2	220
3.551.0046	Pompa per detergente ULKA NME 1C Detergent spraying pump ULKA NME 1C	120	60	2	29	0.2	220
3.551.0045	Pompa per detergente ULKA NME 1C Detergent spraying pump ULKA NME 1C	220	60	2	29	0.2	220
3.752.0173	Pompa per detergente ULKA 28W EP8 Detergent spraying pump ULKA 28W EP8	230	50	2.5	36	0.25	1200
3.752.0029	Pompa per detergente ULKA 28W EP8 Detergent spraying pump ULKA 28W EP8	120	60	2.5	36	0.25	1200
3.752.0054	Pompa per detergente ULKA 48W EP7 Detergent spraying pump ULKA 48W EP7	230	50	7	102	0.7	1000
3.752.0110	Pompa per detergente ULKA 48W EP7 Detergent spraying pump ULKA 48W EP7	240	50	7	102	0.7	1000
3.752.0223	Pompa per detergente ULKA 48W EP7 Detergent spraying pump ULKA 48W EP7	220	60	7	102	0.7	1000
4.208.0313	Antivibrante per pompa detergente Anti-vibration support for detergent spraying pump	---	---	--	---	---	---
3.106.0009	Sistema deareatore per pompa detergente Air eliminator system for detergent spraying pump	---	---	7	102	0.7	1200

Interruttori

Switches



Codice Code	Tipo Type	Tensione Voltage	Frequenza Frequency	Ampere Ampere	Protezione Protection	IP
5.009.0213	Interruttore ON/OFF nero completo di protezione ON/OFF black switch with protecting cover	230/240	50/60	12 (10)	X	55
3.401.0178	Interruttore push nero Black push switch	230/240	50/60	12 (10)	---	55
3.401.0177	Interruttore push verde/rosso Green/red push switch	230/240	50/60	12 (10)	---	55
3.401.0106	Interruttore push con spia Push switch with warning light	230/240	50/60	12 (10)	---	55
5.009.0538	Interruttore ON/OFF nero completo di protezione ON/OFF black switch with protecting cover	230/240	50/60	14 (14)	X	55
3.401.0179	Interruttore push nero Black push switch	230/240	50/60	14 (14)	---	55
5.009.0293	Interruttore luminoso rosso completo di protezione Red backlighted switch with protecting cover	230/240	50/60	14 (14)	X	55
5.009.0294	Interruttore luminoso verde completo di protezione Green backlighted switch with protecting cover	230/240	50/60	14 (14)	X	55
5.009.0480	Interruttore luminoso doppio completo di protezione Double backlighted switch with protecting cover	230/240	50/60	14 (14)	X	55
3.401.0112	Interruttore bipolare 0-1-2 nero completo di protezione Black bipolar switch 0-1-2 with protecting cover	230/240	50/60	12 (10)	X	55
3.401.0191	Interruttore luminoso rosso a soffietto completo di protezione	230/240	50/60	14 (14)		55

Parti elettriche Electric components

Codice Code	Tipo Type	Tensione Voltage	Frequenza Frequency	Potenza max Max power
		V	Hz	W
3.403.0081	Pressostato 5,5 bar per aspiratori ad estrazione <i>Pressure switch 5,5 bar for injection/extraction vacuum cleaners</i>	230-240	50-60	---
3.099.0138	Presca Schuko con guarnizione per elettrodomestici <i>Shuko plug with gasket for power tools</i>	230	50	2200
3.099.0216	Presca Schuko con terra B/NL con guarnizione per elettrodomestici <i>Shuko plug with gasket for power tools</i>	230	50	2200
3.099.1518	Presca CH con guarnizione per elettrodomestici <i>Plug CH with gasket for power tools</i>	230	50	2200
3.099.1512	Presca con guarnizione per elettrodomestici - max 16A <i>Plug with gasket for power tools - max 16A</i>	110	50	1000
3.099.1478	Presca UK con guarnizione per elettrodomestici <i>Plug UK with gasket for power tools</i>	240	50	2200
3.403.0025	Scheda elettronica con ritardo per elettrodomestici <i>Delayed electronic board for power tools</i>	230-240	50-60	2200
3.403.0026	Scheda elettronica senza ritardo per elettrodomestici <i>Undelayed electronic board for power tools</i>	230-240	50-60	2200
3.403.0191	Scheda elettronica con ritardo per elettrodomestici <i>Delayed electronic board for power tools</i>	100-120	50-60	1000



Motori elettrici solo per aspirazione di polveri*Vacuum motors for dusts suction only*

Codice Code	Tipo Type	Tensione Voltage	Frequenza Frequency	Potenza Power	Cavi Cables	Tipo Type
		V	Hz	W	mm	
3.755.0064	Motore monostadio Single stage motor	230-240	50	1100	L = 290	A
3.755.0035	Motore monostadio Single stage motor	230-240	50-60	1100	L = 420	B
3.755.0048	Motore monostadio Single stage motor	230-240	50	1100	---	B
3.755.0055	Motore monostadio Single stage motor	120	60	1100	---	B
3.755.0049	Motore monostadio Single stage motor	120	50-60	1100	L = 420	B
4.212.0019	Cavetti 520 mm per motore aspirazione Cables 520 mm for vacuum motor	---	---	---	---	---

Tipo A
Type A

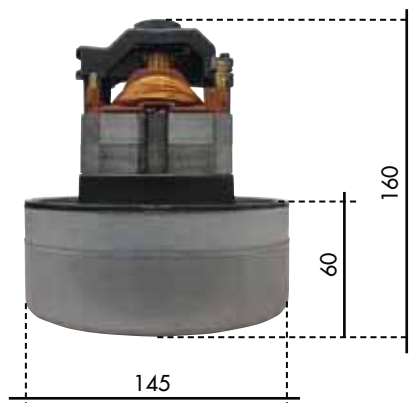

Tipo B
Type B

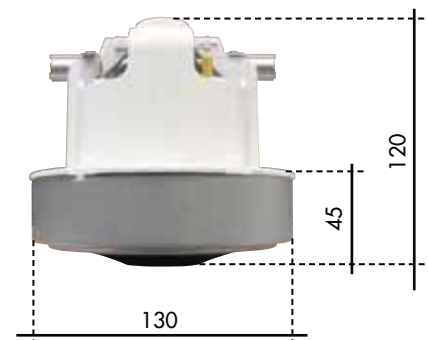

Motori elettrici per aspirazione di liquidi e polveri

Wet & Dry Vacuum motors

Codice Code	Tipo Type	Tensione Voltage	Frequenza Frequency	Potenza Power	Cavi Cables	Tipo Type
		V	Hz	W	mm	
3.755.0043	Motore monostadio - Single stage motor	230-240	50-60	1150	L = 290	C
3.755.0085	Motore monostadio - Single stage motor	230-240	50-60	800	L = 290	E
3.755.0095	Motore monostadio - Single stage motor	230-240	50-60	1000	L = 330	D
3.755.0098	Motore monostadio - Single stage motor	230-240	50-60	1200	L = 290	E
3.755.0070	Motore monostadio - Single stage motor	230-240	50-60	1400	---	C
3.755.0008	Motore monostadio - Single stage motor	100	50-60	1000	L = 290	C
3.755.0020	Motore monostadio (*) - Single stage motor (*)	100	50-60	1000	L = 290	C
3.755.0024	Motore monostadio (*) - Single stage motor (*)	120	60	1200	L = 290	C
3.755.0080	Motore monostadio - Single stage motor	120	60	1200	L = 290	E
4.012.0079	Cavetti 290 mm per motore - Cables 290 mm for motor	---	---	---	---	---
3.755.0026	Motore bistadio by-pass - Two stage by-pass motor	120	50-60	1200	L = 480	F
3.755.0018	Motore bistadio by-pass - Two stage by-pass motor	230-240	50-60	1000	---	F
3.755.0069	Motore bistadio by-pass - Two stage by-pass motor	230-240	50-60	1200	L = 480	F
4.212.0003	Cavetti 480 mm per motore - Cables 480 mm for motor	---	---	---	---	---

(*) con separatore molecolare per filtraggio liquidi
with separator for liquid filtering

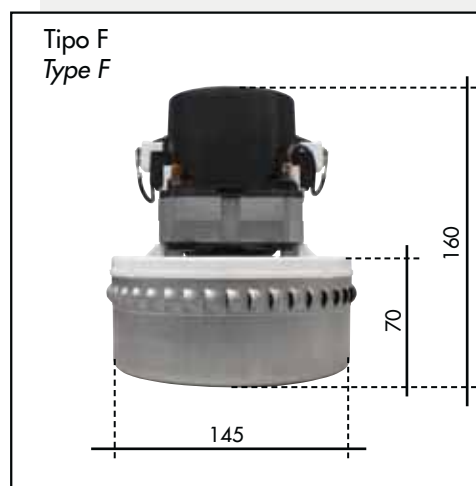
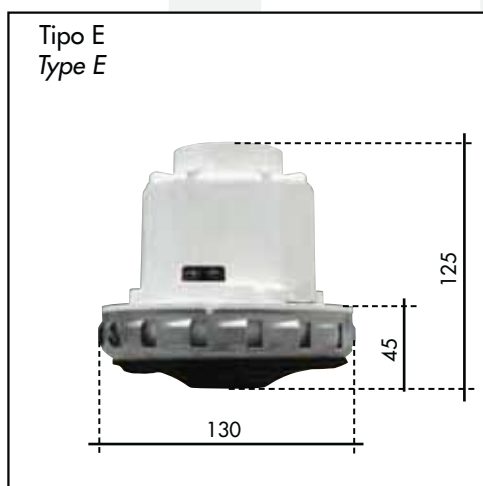
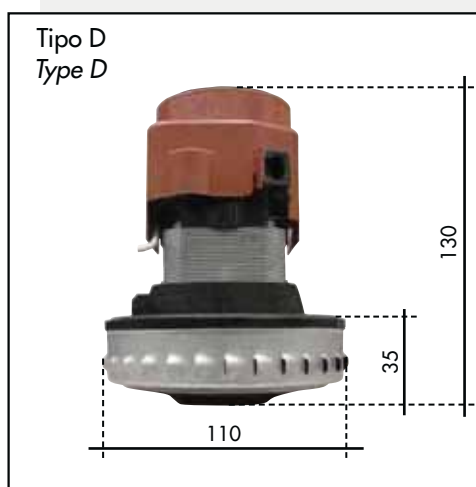
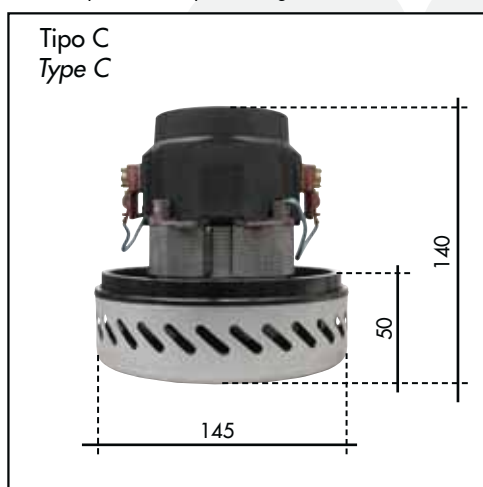

Tubi per aspiratori industriali*Suction hoses for industrial vacuum cleaners*

Codice Code	Tipo Type	Diametro Diameter	Lunghezza min. Min. length	Lunghezza max. Max. length	 Manicotti-Couplings
		mm	m	m	
3.753.0050	Tubo EVA conduttivo EVA conductive hose	38	5 o multipli 5 or multiples	30	0.144.0047 per accessori Ø50-Ø60 for accessories Ø50-Ø60
3.753.0051	Tubo EVA conduttivo EVA conductive hose	50	5 o multipli 5 or multiples	30	0.144.0002 per accessori Ø50-Ø60 for accessories Ø50-Ø60
3.753.0052	Tubo Poliuretano antistatico Polyurethane antistatic hose	40	5 o multipli 5 or multiples	20	0.144.0003 per accessori Ø50-Ø60 for accessories Ø50-Ø60
3.753.0053	Tubo Poliuretano antistatico Polyurethane antistatic hose	50	5 o multipli 5 or multiples	20	0.144.0001 per accessori Ø50-Ø60 for accessories Ø50-Ø60
3.753.0054	Tubo Poliuretano antiolio Polyurethane oil proof hose	50	5 o multipli 5 or multiples	60	0.144.0002 per accessori Ø50-Ø60 for accessories Ø50-Ø60
3.753.0087	Tubo Poliuretano conduttivo Polyurethane conductive hose	70	5 o multipli 5 or multiples	20	0.144.0052 per accessori Ø50-Ø60 for accessories Ø50-Ø60



EVA CONDUTTIVO
Leggerissimo/alta flessibilità.

EVA CONDUCTIVE
Lightness and high flexibility.



POLIURETANO ANTISTATICO
Leggero/media flessibilità.

POLYURETHANE ANTISTATIC
Lightness and moderate flexibility.



POLIURETANO ANTIOILIO
Resistente agli olii e alle forti abrasioni.

POLYURETHANE OIL PROOF
Antistatic, oil and abrasion proof.

WORB **WAVE** **CD**

MONOSPAZZOLE

SINGLE DISC MACHINES

SEER **VI**

MONOSPAZZOLE SINGLE DISC MACHINES

ACCESSORI

- Spazzole
- Trascinatori e dischi abrasivi
- Distributori
- Prodotti chimici e detergenti

ACCESSORIES

- *Brushes*
- *Pad drivers and abrasive pads*
- *Spray systems*
- *Chemical products and detergents*

pag.

134
134
136
136





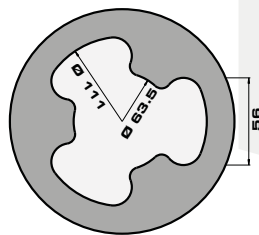



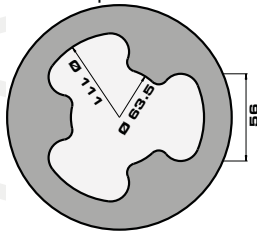

Flangia di innesto spazzole e trascinatori











Descrizione	Codice	Dimensioni [mm/inches]	Deceratura di pavimenti in materiali sintetico (PVC).	Deceratura di pavimenti con presenza di sughero (linoleum).	Pulizia di fondo di pietre (marmo), ceramica e linoleum	Pulizia di superfici in PVC e linoleum incerate.	Cristallizzazione di superfici calcaree, come ad es. marmo	Shampoo per tappeti.	Levigatura pavimenti in legno	Levigatura pavimenti in cemento.	Pulizia con spray.	Lucidatura e finitura pavimenti.
Spazzole												
	Spazzola moquette	0.955.0013	330/13					x				
	Spazzola moquette	0.955.0014	430/17					x				
	Spazzola moquette	0.955.0020	505/20					x				
	Spazzola PP 0,6 mm	0.955.0006	330/13	x	x							
	Spazzola PP 0,6 mm	0.955.0007	430/17	x	x							
	Spazzola PP 0,6 mm	0.955.0008	505/20	x	x							
	Spazzola per lucidare	0.955.0009	330/13								x	x
	Spazzola per lucidare	0.955.0010	430/17								x	x
	Spazzola per lucidare High Speed	0.955.0011	430/17								x	x
	Spazzola per lucidare	0.955.0012	505/20								x	x
	Spazzola abrasiva Tynex	0.955.0003	330/13	x			x					
	Spazzola abrasiva Tynex	0.955.0004	430/17	x			x					
Spazzola abrasiva Tynex	0.955.0005	505/20	x			x						
Dischi trascinatori per pad												
	Disco trascinatore EWU	0.955.0015	330/13	x	x	x	x	x			x	x
	Disco trascinatore EWU	0.955.0016	430/17	x	x	x	x	x			x	x
	Disco trascinatore EWU High Speed	0.955.0017	430/17	x	x	x	x	x			x	x
	Disco trascinatore EWU	0.955.0021	505/20	x	x	x	x	x			x	x
Dischi pad												
	Pad microfibra 5 pcs	6.508.0115	330/13					x				
	Pad microfibra 2 pcs	6.508.0116	430/17					x				
	Pad beige 5 pcs	6.508.0032	430/17									x
	Pad cream 5 pcs	0.955.0018	406/16									x
	Pad cream 5 pcs	0.955.0019	460/18									x
	Pad rosso 5 pcs	6.508.0117	330/13			x						x
	Pad rosso 5 pcs	6.508.0118	430/17			x						x
	Pad rosso 5 pcs	6.508.0119	505/20			x						x
	Pad verde 5 pcs	6.508.0037	340/13,5		x		x					
	Pad verde 5 pcs	6.508.0039	430/17		x		x					
	Pad verde 5 pcs	6.508.0120	505/20		x		x					
	Pad nero 5 pcs	6.508.0044	340/13,5	x								
	Pad nero 5 pcs	6.508.0046	430/17	x								
	Pad nero 5 pcs	6.508.0123	505/20	x								
Pad argento Inox 5 pcs	6.508.0121	430/17					x					
Pad argento Inox 5 pcs	6.508.0122	505/20					x					
Dischi trascinatori per abrasivi												
	Disco trascinatore per abrasivi	0.955.0022	Universale						x	x		
Dischi Abrasivi												
	Disco carta abrasiva grana 24	0.955.0023	430/17						x			
	Disco carta abrasiva grana 60	0.955.0024	430/17						x			
	Disco Vidia grana 24	0.955.0026	430/17								x	
	Disco Vidia grana 36	0.955.0025	430/17								x	
Dischi speciali												
	Disco Carborundum	0.955.0027	Universale							x		

Coupling flange for brushes and pad holders



Description	Code	Dimensions [mm/inches]	Stripping synthetic floor (PVC)	Stripping cork present floor (linoleum)	Wet scrubbing/basic cleaning of stones, tiles and lino (sensitive floors)	Wet scrubbing/basic cleaning of synthetic or non sensitive floors pvc	Crystallizing	Carpet shampooing	Sanding wood	Sanding cement	Spray cleaning	Spray polishing and buffing
Brushes												
 Carpet brush	0.955.0013	330/13						x				
Carpet brush	0.955.0014	430/17						x				
Carpet brush	0.955.0020	505/20						x				
 Scrubbing brush PP 0,6 mm	0.955.0006	330/13		x	x							
Scrubbing brush PP 0,6 mm	0.955.0007	430/17		x	x							
Scrubbing brush PP 0,6 mm	0.955.0008	505/20		x	x							
 Polishing brush	0.955.0009	330/13									x	x
Polishing brush	0.955.0010	430/17									x	x
Polishing brush High Speed	0.955.0011	430/17									x	x
Polishing brush	0.955.0012	505/20									x	x
 Tynex brush	0.955.0003	330/13	x			x						
Tynex brush	0.955.0004	430/17	x			x						
Tynex brush	0.955.0005	505/20	x			x						
Pad Holders												
 EWU pad holder	0.955.0015	330/13	x	x	x	x	x				x	x
EWU pad holder	0.955.0016	430/17	x	x	x	x	x				x	x
EWU pad holder High Speed	0.955.0017	430/17	x	x	x	x	x				x	x
EWU pad holder EWU	0.955.0021	505/20	x	x	x	x	x				x	x
Pads												
 Pad micro fiber 5 pcs	6.508.0115	330/13						x				
Pad micro fiber 2 pcs	6.508.0116	430/17						x				
Pad beige 5 pcs	6.508.0032	430/17										x
Pad cream 5 pcs	0.955.0018	406/16										x
Pad cream 5 pcs	0.955.0019	460/18										x
Pad red 5 pcs	6.508.0117	330/13			x						x	
Pad red 5 pcs	6.508.0118	430/17			x						x	
Pad red 5 pcs	6.508.0119	505/20			x						x	
Pad green 5 pcs	6.508.0037	340/13,5		x		x						
Pad green 5 pcs	6.508.0039	430/17		x		x						
Pad green 5 pcs	6.508.0120	505/20		x		x						
Pad black 5 pcs	6.508.0044	340/13,5	x									
Pad black 5 pcs	6.508.0046	430/17	x									
Pad black 5 pcs	6.508.0123	505/20	x									
Pad silver Inox 5 pcs	6.508.0121	430/17					x					
Pad silver Inox 5 pcs	6.508.0122	505/20					x					
Holders for abrasive discs												
 Abrasive Disc Holder	0.955.0022	Universal							x	x		
Abrasive discs												
 Emery paper GR24 disc	0.955.0023	430/17							x			
Emery paper GR60 disc	0.955.0024	430/17							x			
Vidia disc GR24	0.955.0026	430/17								x		
Vidia disc GR36	0.955.0025	430/17								x		
Special Discs												
 Carborandum disc	0.955.0027	Universal									x	

				Deceratura di pavimenti in materiali sintetico (PVC).	Deceratura di pavimenti con presenza di sughero (linoleum).	Pulizia di fondo di pietre (marmo), ceramica e linoleum	Pulizia di superfici in PVC e linoleum incerate.	Cristallizzazione di superfici calcaree, come ad es. marmo	Shampoo per tappeti	Levigatura pavimenti in legno	Levigatura pavimenti in cemento.	Pulizia con spray.	Lucidatura e finitura pavimenti.	
Serbatoio detergente universale completo 	0.955.0001			X	X	X	X		X					
Sistema Spray universale con attacchi  	0.955.0002			X	X	X	X	X	X			X		
Detergenti 	LCN-800F	3.697.0023	4 x 5 l	X	X	X	X							
	LCN-800	3.697.0024	4 x 5 l	X	X	X	X							
	LCN-680AL	3.697.0025	4 x 5 l			X						X	X	
	LCN-650	3.697.0026	4 x 5 l				X					X		
	LCN-640WM	3.697.0027	4 x 5 l									X	X	
	LCB-900WR	3.697.0030	4 x 5 l	X										
	LCB-740F	3.697.0031	4 x 5 l			X								
	LCN-600SVF	3.697.0033	4 x 5 l	X		X	X							
	LCN-700	3.697.0035	4 x 5 l						X					

				Stripping synthetic floor (PVC).	Stripping cork present floor (linoleum).	Wetscrubbing/basic cleaning of stones (marble), tiles and linoleum	Wetscrubbing/basic cleaning of synthetic or non-sensitive floors (PVC)	Crystallizing	Carpet shampooing.	Sanding wood	Sanding cement	Spray cleaning	Spray polishing and buffing
Universal detergent tank 			0.955.0001	X	X	X	X		X				
Complete universal Spray System  			0.955.0002	X	X	X	X	X	X			X	
Detergents 			LCN-800F	3.697.0023	4 x 5 l	X	X	X	X				
			LCN-800	3.697.0024	4 x 5 l	X	X	X	X				
			LCN-680AL	3.697.0025	4 x 5 l			X				X	X
			LCN-650	3.697.0026	4 x 5 l				X			X	
			LCN-640WM	3.697.0027	4 x 5 l							X	X
			LCB-900WR	3.697.0030	4 x 5 l	X							
			LCB-740F	3.697.0031	4 x 5 l			X					
			LCN-600SVF	3.697.0033	4 x 5 l	X		X	X				
			LCN-700	3.697.0035	4 x 5 l					X			

WORWAG

LAVASCIUGAPAVIMENTI

SCRUBBER DRIERS

SEERVI

LAVASCIUGAPAVIMENTI SCRUBBER DRIERS

ACCESSORI

- Batterie, caricabatterie e connettori
- Spazzole
- Dischi trascinatori e pad
- Lame in gomma per tergipavimento

RICAMBI

- Ruote
- Valvole a sfera
- Riduttori
- Motori di trazione
- Motori per spazzola
- Motori di aspirazione
- Contatore e indicatori di batteria
- Galleggianti
- Elettrovalvole
- Protettori termici
- Fusibili

ACCESSORIES

- Batteries, battery chargers and connectors 140
- Brushes 145
- Pad drivers and pads 146
- Rubber squeegee blades 147

SPARE PARTS

- Wheels 150
- Ball valves 151
- Reduction gears 151
- Traction motors 152
- Brush motors 152
- Vacuum motors 153
- Hour meters and battery power tests 154
- Floating switches 154
- Solenoid valves 154
- Thermal circuit breakers 155
- Fuses 155



Batteria da trazione "Piombo-Acido" a piastra piana*PB-Acid plane plate traction battery*

Codice Code	Tensione Voltage	Capacità 5h 5Hr Rate	Capacità 20h 20Hr Rate	Cicli Cycles	Dimensioni (mm): Dimensions (mm):			Tipo Attacco Terminal Type
	Volt	Ah	Ah		Lung. (L)	Largh. (W)	Alt. (H)	
0.107.0003	6	180	240	600	245	190	255	Polo Auto Automotive Post
0.107.0001	12	60	80	600	242	175	190	Polo Auto Automotive Post

Batteria da trazione "Piombo-Acido" a piastra tubolare (corazzata)*PB-Acid tubular plate traction battery*

Codice Code	Tensione Voltage	Capacità 5h 5Hr Rate	Capacità 20h 20Hr Rate	Cicli Cycles	Dimensioni (mm): Dimensions (mm):			Tipo Attacco Terminal Type
	Volt	Ah	Ah		Lung. (L)	Largh. (W)	Alt. (H)	
0.107.0034	6	240	265	1200	243	198	360	Polo Auto Automotive Post
0.107.0004	6	180	240	1200	242	190	275	Polo Auto Automotive Post
0.107.0014	12	85	105	1200	308	175	225	Polo Auto Automotive Post
0.107.0002	12	118	157	1200	345	170	285	Polo Auto Automotive Post

Batteria VRLA (senza manutenzione) da trazione con tecnologia Spiralcell al piombo puro*VRLA maintenance free battery with Spiralcell technology*

Codice Code	Tensione Voltage	Capacità 5h 5Hr Rate	Capacità 20h 20Hr Rate	Cicli Cycles	Dimensioni (mm): Dimensions (mm):			Tipo Attacco Terminal Type
	Volt	Ah	Ah		Lung. (L)	Largh. (W)	Alt. (H)	
0.107.0050	12	52	55	400-500	254	175	200	Polo Auto + Perno M6 Automotive Post & Stud M6
0.107.0054	12	72	75	400-500	325	165	238	Polo Auto + Perno M6 Automotive Post & Stud M6

- * Ricarica veloce ed elevato raggio di azione
- * Maggiore produttività, grazie all'elevata capacità giornaliera di pulizia.
- * Tecnologia "verde" all'avanguardia, duratura, nel rispetto di ambiente, salute e sicurezza
- * A tenuta stagna, non richiede manutenzione, facile da gestire
- * Estremamente resistente alle vibrazioni, anche in presenza di fondo difficile
- * Dura sino a due volte di più

- * Rapid recharging and a greater action radius
- * Increased productivity through enhanced daily cleaning capacity
- * Cutting-edge, sustainable green technology in the area of environment, health and safety (EH&S)
- * Spill-proof, absolutely maintenance-free and easy to handle
- * Extremely vibration-resistant even over difficult terrain
- * Up to twice the customary service life

Batteria VRLA (senza manutenzione) da trazione con tecnologia "GEL"*GEL technology maintenance free battery*

Codice Code	Tensione Voltage	Capacità 5h 5Hr Rate	Capacità 20h 20Hr Rate	Cicli Cycles	Dimensioni (mm): Dimensions (mm):			Tipo Attacco Terminal Type
	Volt	Ah	Ah		Lung. (L)	Largh. (W)	Alt. (H)	
0.107.0033	6	180	240	700-800	242	190	275	Polo Auto Automotive Post
0.107.0063	12	105	120	700-800	243	198	360	Polo Auto Automotive Post

Batteria da trazione Piombo-Acido "elementi a cassone"*PB-Acid traction battery box*

Codice Code	Tensione Voltage	Capacità 5h 5Hr Rate	Capacità 10h 10Hr Rate	Cicli Cycles	Dimensioni (mm): Dimensions (mm):			Tipo Attacco Terminal Type
	Volt	Ah	Ah		Lung. (L)	Largh. (W)	Alt. (H)	
0.107.0008	24	500	585	1200	610	410	535	Polo Auto Automotive Post
0.107.0009	36	360	421	1200	610	525	510	Polo Auto Automotive Post
0.107.0010	36	525	614	1200	610	610	550	Polo Auto Automotive Post

Batteria VRLA (senza manutenzione) da trazione con tecnologia "GEL" "elementi a cassone"*VRLA maintenance free traction battery box - GEL*

Codice Code	Tensione Voltage	Capacità 5h 5Hr Rate	Capacità 20h 20Hr Rate	Cicli Cycles	Dimensioni (mm): Dimensions (mm):			Tipo Attacco Terminal Type
	Volt	Ah	Ah		Lung. (L)	Largh. (W)	Alt. (H)	
0.107.0011	24	400	468	800	610	410	535	Polo Auto Automotive Post
0.107.0012	36	320	374	800	610	525	510	Polo Auto Automotive Post
0.107.0013	36	400	468	800	610	610	550	Polo Auto Automotive Post

Coppia poli conici per batteria*Automotive post terminal (couple)*

Codice Code	Attacco Coupling	Quantità Quantity
0.107.0031	M6 M	1 pos. 1 neg.
0.107.0047	M8 M	1 pos. 1 neg.

Caricabatterie universali programmabili ad alta frequenza*Universal programmable high-frequency battery charger*

Codice Code	Voltaggio batteria Battery Voltage	Capacità di carica Charging current	Dimensioni (mm): Dimensions (mm):			Parametri Operating parameters	
	Volt		A	Lung. (L)	Largh. (W)	Alt. (H)	V
0.108.0001	12/24	12	205	255	140	220/240	50/60
0.108.0002	12/24	30	404	355	195	220/240	50/60
0.108.0003	24/36	60	505	485	245	220/240	50/60

Come scegliere il caricabatteria adatto.

La corretta capacità di carica del caricabatteria si determina calcolando l'11% della capacità in 5h della batteria da ricaricare

Esempio: batteria 0.107.0002 con capacità 5h = 118 Ah ; $118 \times 11\% = 12,8$ - Il caricabatteria adatto è il 0.108.0001 che ha capacità di carica 12A.

How to choose the right charger.

The correct charge capacity of the battery charger is determined by calculating the 11% of the 5 hours rate of the battery to be recharged

Example: 0.107.0002 battery with 5 hours rate = 118 Ah: $118 \times 11\% = 12.8$ - The right charger is 0.108.0001, whose charge capacity is 12A.

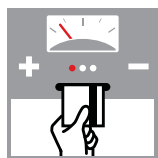
Smartcard per configurazione caricabatteria*Smartcard for battery charger setting*

Codice Code	Per caricare batteria: Suitable to charge battery:	Curva di carica Charging curve	Ampere	Volts
0.108.0006	Cassone 0.107.0008 Piombo-Acido Box 0.107.0008 Pb-Acid	IUIa-Acd	60	24
0.108.0007	Cassone 0.107.0011 GEL Box 0.107.0011 GEL	IUIa-PzVGel	50	24
0.108.0008	Cassone 0.107.0009 Piombo-Acido Box 0.107.0009 Pb-Acid	IUIa-Acd	50	36
0.108.0009	Cassone 0.107.0012 - 0.107.0013 GEL Box 0.107.0012 - 0.107.0013 GEL	IUIa-PzVGel	50	36
0.108.0010	Cassone 0.107.0010 Piombo-Acido Box 0.107.0010 Pb-Acid	IUIa-Acd	60	36

Caricabatterie rapido*Booster battery charger*

Codice Code	Descrizione Description	Vtaggio batteria Battery Voltage	Capacità di carica Charging current	Dimensioni (mm): Dimensions (mm):			Parametri Operating parameters	
				Lung. (L)	Largh. (W)	Alt. (H)	V	Hz
0.108.0051	CBHF2	12	30	300	180	100	220/240	50/60

Caricabatterie a bordo*On-board battery charger*

Codice Code	Descrizione Description	Vtaggio batteria Battery Voltage	Capacità di carica Charging current	Dimensioni (mm): Dimensions (mm):			Parametri Operating parameters	
				Lung. (L)	Largh. (W)	Alt. (H)	V	Hz
5.511.1641	CBHF1-SM	24	12	220	130	55	220/240	50/60
0.108.0031	CBHD1 - IUJA-ACD	24	10	145	130	60	220/240	50/60
0.108.0042	CBHD1 - IUJA-GEL	24	10	170	130	60	220/240	50/60
5.511.1800	CBHD1	12	6	130	110	60	220/240	50/60
0.108.0048	CBHF1-SM	24	12	200	125	80	220/240	50/60
0.108.0049	CBHF2	24	25	250	160	70	220/240	50/60

Cavo per caricabatterie a bordo*Power cord for on-board battery charger*

Codice Code	Lunghezza cavo Cable length	Sezione cavo Wire section	Tipo di spina Plug type
	mt		
0.108.0025	1,5	3 x 0.75 mm ²	EU SHUKO
0.108.0028	1,5	3 x 0.75 mm ²	AUSTRALIA
0.108.0027	1,5	3 x 0.75 mm ²	UK
0.108.0026	1,5	3 x AWG16	USA

Trasferimento dati per caricabatterie*Battery charger data transfer*

Codice Code	Descrizione Description	Per caricabatteria For battery charger
0.108.0053	Software lettura dati per caricabatterie Data reader software for battery charger	0.108.0045 - CBHD1
0.108.0050	Cavo seriale per trasmissione dati da caricabatteria a PC Serial cable for	0.108.0045 - CBHD1

Cavi, morsetti e cappucci per batterie*Cables, cable terminals and terminals cover for batteries*

Codice Code	Descrizione Description
3.405.0118	Morsetto negativo ad occhiello <i>Eyelet cable terminal - negative</i>
3.405.0119	Morsetto positivo ad occhiello <i>Eyelet cable terminal - positive</i>
3.405.0046	Morsetto negativo per terminale conico <i>Cable terminal for automotive post battery terminal - negative</i>
3.405.0047	Morsetto positivo per terminale conico <i>Cable terminal for automotive post battery terminal - positive</i>
3.405.0113	Cappuccio nero negativo <i>Black terminal cover - negative</i>
3.405.0114	Cappuccio rosso positivo <i>Red terminal cover - positive</i>
5.511.0561	Cavo completo di morsetto per polo auto e cappuccio <i>Cable assembly with automotive post terminals and terminal covers</i>

Connettori, maniglie per connettori e contatti*Connectors, connector handles and contacts*

Codice Code	Descrizione Description	Voltaggio Voltage	Corrente Current
		V	A
3.099.0808	Impugnatura universale con viti <i>Universal connector handle with screws</i>	12-24	50
3.499.0029	Connettore completo di contatti <i>Connector with contacts</i>	12-24	50
3.499.0313	Contatto <i>Contact</i>	12-24	50
3.499.0246	Connettore <i>Connector</i>	24-36	80
3.499.0249	Contatto per cavi di sezione 16 mm <i>Contact for cables 16 mm diameter</i>	24-36	80
3.499.0247	Contatto per cavi di sezione 25 mm <i>Contact for cables 25 mm diameter</i>	24-36	80
3.499.0248	Maniglia con viti <i>Connector handle with screws</i>	24-36	80
3.499.0036	Connettore <i>Connector</i>	24-36	160
3.499.0051	Connettore grigio <i>Grey connector</i>	36	160
3.499.0352	Contatto <i>Contact</i>	24-36	160
3.499.0037	Impugnatura <i>Connector handle</i>	24-36	160

Spazzole PPL con placca innesto dx/sx universale*PPL brushes for scrubber driers with universal left/right coupling flange*

Codice Code	Descrizione Description	Diametro disco Disc diameter		Setole Bristles
		mm	inches	
5.511.1101	Spazzola PPL con placca innesto universale PPL brush with universal coupling flange	265	10.5"	0.6
5.511.1105	Spazzola PPL con placca innesto universale PPL brush with universal coupling flange	330	13"	0.6
5.511.1168	Spazzola PPL con placca innesto universale PPL brush with universal coupling flange	360	14"	0.6
5.511.1346	Spazzola PPL con placca innesto universale PPL brush with universal coupling flange	360	14"	0.6 Verticali Vertical
5.511.1411	Spazzola PPL con placca innesto universale PPL brush with universal coupling flange	360	14"	0.3 Verticali Vertical
5.511.1109	Spazzola PPL con placca innesto universale PPL brush with universal coupling flange	406	16"	0.6
5.511.1093	Spazzola PPL con placca innesto universale PPL brush with universal coupling flange	431	17"	0.6
5.511.1097	Spazzola PPL con placca innesto universale PPL brush with universal coupling flange	483	19"	0.6

Spazzole TYNEX con placca innesto dx/sx universale*TYNEX abrasive brushes with universal left/right coupling flange*

Codice Code	Descrizione Description	Diametro disco Disc diameter	
		mm	inches
5.511.1102	Spazzola Tynex con placca innesto universale Tynex brush with universal coupling flange	265	10.5"
5.511.1106	Spazzola Tynex con placca innesto universale Tynex brush with universal coupling flange	330	13"
5.511.1246	Spazzola Tynex con placca innesto universale Tynex brush with universal coupling flange	360	14"
5.511.1413	Spazzola Tynex con placca innesto universale Tynex brush with universal coupling flange SETOLE VERTICALI - VERTICAL BRISTLES	360	14"
5.511.1110	Spazzola Tynex con placca innesto universale Tynex brush with universal coupling flange	406	16"
5.511.1094	Spazzola Tynex con placca innesto universale Tynex brush with universal coupling flange	431	17"
5.511.1098	Spazzola Tynex con placca innesto universale Tynex brush with universal coupling flange	483	19"

Dischi trascinatori tipo EWU con placca innesto dx/sx universale

EWU pad drivers for abrasive pads with universal left/right coupling flange



Codice Code	Descrizione Description	Diametro disco Disc diameter	
		mm	inches
5.511.1103	Trascinatore EWU ccon placca innesto universale <i>EWU pad driver with universal coupling flange</i>	265	10.5"
5.511.1107	Trascinatore EWU ccon placca innesto universale <i>EWU pad driver with universal coupling flange</i>	330	13"
5.511.1129	Trascinatore EWU ccon placca innesto universale <i>EWU pad driver with universal coupling flange</i>	360	14"
5.511.1111	Trascinatore EWU ccon placca innesto universale <i>EWU pad driver with universal coupling flange</i>	406	16"
5.511.1095	Trascinatore EWU ccon placca innesto universale <i>EWU pad driver with universal coupling flange</i>	431	17"
5.511.1099	Trascinatore EWU ccon placca innesto universale <i>EWU pad driver with universal coupling flange</i>	483	19"

Dischi abrasivi universali

Abrasive pads



Codice Code	Descrizione Description	Colore Colour	Diametro disco Disc diameter		Confezione
			mm	inches	Pezzi - Pcs
6.508.0095	Disco abrasivo - <i>Abrasive pad</i>	Beige	280	11"	10
6.508.0030	Disco abrasivo - <i>Abrasive pad</i>	Beige	340	13.5"	5
6.508.0108	Disco abrasivo - <i>Abrasive pad</i>	Beige	356	14"	5
6.508.0031	Disco abrasivo - <i>Abrasive pad</i>	Beige	406	16"	5
6.508.0032	Disco abrasivo - <i>Abrasive pad</i>	Beige	431	17"	5
6.508.0034	Disco abrasivo - <i>Abrasive pad</i>	Beige	483	19"	5
6.508.0096	Disco abrasivo - <i>Abrasive pad</i>	Verde Green	280	11"	10
6.508.0037	Disco abrasivo - <i>Abrasive pad</i>	Verde Green	340	13.5"	5
6.508.0109	Disco abrasivo - <i>Abrasive pad</i>	Verde Green	356	14"	5
6.508.0038	Disco abrasivo - <i>Abrasive pad</i>	Verde Green	406	16"	5
6.508.0039	Disco abrasivo - <i>Abrasive pad</i>	Verde Green	431	17"	5
6.508.0041	Disco abrasivo - <i>Abrasive pad</i>	Verde Green	483	19"	5
6.508.0097	Disco abrasivo - <i>Abrasive pad</i>	Nero Black	280	11"	10
6.508.0044	Disco abrasivo - <i>Abrasive pad</i>	Nero Black	340	13.5"	5
6.508.0110	Disco abrasivo - <i>Abrasive pad</i>	Nero Black	356	14"	5
6.508.0045	Disco abrasivo - <i>Abrasive pad</i>	Nero Black	406	16"	5
6.508.0046	Disco abrasivo - <i>Abrasive pad</i>	Nero Black	431	17"	5
6.508.0048	Disco abrasivo - <i>Abrasive pad</i>	Nero Black	483	19"	5



Placca di innesto dx/sx universale per spazzole e dischi trascinatori

Universal left/right coupling flange for brushes and pad drivers

Codice Code	Descrizione Description
4.508.1192	Placca per innesto spazzola simmetrica Coupling flange for brushes and pad drivers

Lame in gomma naturale per tergipavimento

Natural rubber squeegee blades



Codice Code	Descrizione Description	Durezza Hardness	Colore Colour	Dimensioni (mm): Dimensions (mm):		
				Lung. (L)	Alt. (H)	Spess. (Th)
		Sh.				
4.508.1040	Lama anteriore per tergipavimento Front squeegee blade	40	Naturale Natural	537	50	2.5
4.508.1041	Lama posteriore per tergipavimento Rear squeegee blade	40	Naturale Natural	590	50	3
4.508.0171	Lama anteriore per tergipavimento Front squeegee blade	40	Naturale Natural	750	50	3
4.508.0468	Lama anteriore per tergipavimento Front squeegee blade	40	Naturale Natural	830	55	3
4.508.0090	Lama anteriore per tergipavimento Front squeegee blade	40	Naturale Natural	860	50	3
4.508.0600	Lama anteriore per tergipavimento Front squeegee blade	40	Naturale Natural	860	50	3
4.508.0646	Lama anteriore per tergipavimento Front squeegee blade	48	Naturale Natural	920	45	3
4.508.0184	Lama anteriore per tergipavimento Front squeegee blade	40	Naturale Natural	1020	50	3
4.508.0602	Lama anteriore per tergipavimento Front squeegee blade	40	Naturale Natural	1020	50	3
4.508.1196	Lama anteriore per tergipavimento Front squeegee blade	40	Naturale Natural	1025	47	3

Lame in gomma naturale per tergipavimento

Natural rubber squeegee blades

Codice Code	Descrizione Description	Durezza Hardness	Colore Colour	Dimensioni (mm): Dimensions (mm):		
				Lung. (L)	Alt. (H)	Spess. (Th)
		Sh.				
4.508.0170	Lama posteriore per tergipavimento <i>Rear squeegee blade</i>	30	Rosso <i>Red</i>	750	50	4
4.508.0601	Lama posteriore per tergipavimento <i>Rear squeegee blade</i>	40	Naturale <i>Natural</i>	860	50	4
4.508.0089	Lama posteriore per tergipavimento <i>Rear squeegee blade</i>	30	Rosso <i>Red</i>	860	50	4
4.508.0467	Lama posteriore per tergipavimento <i>Rear squeegee blade</i>	40	Naturale <i>Natural</i>	870	55	4
4.508.0213	Lama anteriore per tergipavimento <i>Front squeegee blade</i>	45	Naturale <i>Natural</i>	890	45	4
4.508.0605	Lama posteriore per tergipavimento <i>Rear squeegee blade</i>	40	Rosso <i>Red</i>	1000	70	4
4.508.0185	Lama posteriore per tergipavimento <i>Rear squeegee blade</i>	30	Rosso <i>Red</i>	1020	50	4
4.508.0603	Lama posteriore per tergipavimento <i>Rear squeegee blade</i>	40	Naturale <i>Natural</i>	1020	50	4
4.508.0215	Lama anteriore per tergipavimento <i>Front squeegee blade</i>	45	Naturale <i>Natural</i>	1110	45	4
4.508.1195	Lama posteriore per tergipavimento <i>Rear squeegee blade</i>	40	Rosso <i>Red</i>	1145	70	4
4.508.0217	Lama anteriore per tergipavimento <i>Front squeegee blade</i>	45	Naturale <i>Natural</i>	1270	45	4
4.508.0219	Lama anteriore per tergipavimento <i>Front squeegee blade</i>	40	Naturale <i>Natural</i>	1500	45	4
4.508.0172	Lama posteriore per tergipavimento <i>Rear squeegee blade</i>	30	Rosso <i>Red</i>	750	50	5
4.508.0147	Lama posteriore per tergipavimento <i>Rear squeegee blade</i>	30	Rosso <i>Red</i>	860	50	5
4.508.0216	Lama posteriore per tergipavimento <i>Rear squeegee blade</i>	40	Rosso <i>Red</i>	1345	70	5
4.508.0570	Lama posteriore per tergipavimento <i>Rear squeegee blade</i>	35	Rosso <i>Red</i>	945	70	6
4.508.0212	Lama posteriore per tergipavimento <i>Rear squeegee blade</i>	40	Rosso <i>Red</i>	965	70	6
4.508.0214	Lama posteriore per tergipavimento <i>Rear squeegee blade</i>	38	Rosso <i>Red</i>	1185	70	6
4.508.0449	Lama posteriore per tergipavimento <i>Rear squeegee blade</i>	40	Rosso <i>Red</i>	1290	70	6
4.508.0218	Lama posteriore per tergipavimento <i>Rear squeegee blade</i>	38	Rosso <i>Red</i>	1580	70	6

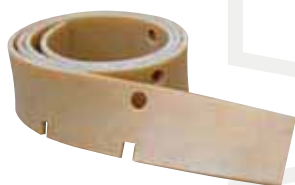

Lame in poliuretano per tergipavimento

Polyurethane squeegee blades

Codice Code	Descrizione Description	Durezza Hardness	Colore Colour	Dimensioni (mm): Dimensions (mm):		
				Lung. (L)	Alt. (H)	Spess. (Th)
		Sh.				
4.508.0270	Lama anteriore in poliuretano per tergipavimento <i>Polyurethane front squeegee blade</i>	90	Trasparente <i>Transparent</i>	1290	50	1.5
4.508.0571	Lama anteriore in poliuretano per tergipavimento <i>Polyurethane front squeegee blade</i>	85	Trasparente <i>Transparent</i>	935	50	2
4.508.1058	Lama anteriore in poliuretano per tergipavimento <i>Polyurethane front squeegee blade</i>	45	Trasparente <i>Transparent</i>	537	50	2.5
4.508.1059	Lama posteriore in poliuretano per tergipavimento <i>Polyurethane rear squeegee blade</i>	50	Trasparente <i>Transparent</i>	590	50	3
4.508.0895	Lama anteriore in poliuretano per tergipavimento <i>Polyurethane front squeegee blade</i>	40	Rosso <i>Red</i>	860	50	3
4.508.1178	Lama anteriore in poliuretano per tergipavimento <i>Polyurethane front squeegee blade</i>	40	Trasparente <i>Transparent</i>	830	55	3
4.508.0894	Lama anteriore in poliuretano per tergipavimento <i>Polyurethane front squeegee blade</i>	40	Rosso <i>Red</i>	1020	50	3
4.508.1251	Lama anteriore in poliuretano per tergipavimento <i>Polyurethane front squeegee blade</i>	45	Trasparente <i>Transparent</i>	1020	47	3
4.508.0896	Lama posteriore in poliuretano per tergipavimento <i>Polyurethane rear squeegee blade</i>	33	Rosso <i>Red</i>	860	50	4
4.508.1177	Lama posteriore in poliuretano per tergipavimento <i>Polyurethane rear squeegee blade</i>	40	Naturale <i>Natural</i>	870	55	4
4.508.0847	Lama posteriore in poliuretano per tergipavimento <i>Polyurethane rear squeegee blade</i>	45	Naturale <i>Natural</i>	870	55	4
4.508.0901	Lama anteriore in poliuretano per tergipavimento <i>Polyurethane front squeegee blade</i>	40	Naturale <i>Natural</i>	925	45	4
4.508.0893	Lama posteriore in poliuretano per tergipavimento <i>Polyurethane rear squeegee blade</i>	33	Rosso <i>Red</i>	1020	50	4
4.508.1166	Lama anteriore in poliuretano per tergipavimento <i>Polyurethane front squeegee blade</i>	33	Trasparente <i>Transparent</i>	1110	45	4
4.508.1252	Lama posteriore in poliuretano per tergipavimento <i>Polyurethane rear squeegee blade</i>	45	Rosso <i>Red</i>	1140	70	4
4.508.1167	Lama anteriore in poliuretano per tergipavimento <i>Polyurethane front squeegee blade</i>	45	Trasparente <i>Transparent</i>	1330	45	4
4.508.1169	Lama anteriore in poliuretano per tergipavimento <i>Polyurethane front squeegee blade</i>	45	Trasparente <i>Transparent</i>	1550	45	4
4.508.0897	Lama posteriore in poliuretano per tergipavimento <i>Polyurethane rear squeegee blade</i>	33	Naturale <i>Natural</i>	1400	70	5
4.508.0900	Lama posteriore in poliuretano per tergipavimento <i>Polyurethane rear squeegee blade</i>	40	Naturale <i>Natural</i>	950	70	5
4.508.1168	Lama posteriore in poliuretano per tergipavimento <i>Polyurethane rear squeegee blade</i>	45	Trasparente <i>Transparent</i>	1580	70	5
4.508.1165	Lama posteriore in poliuretano per tergipavimento <i>Polyurethane rear squeegee blade</i>	33	Trasparente <i>Transparent</i>	1185	70	6

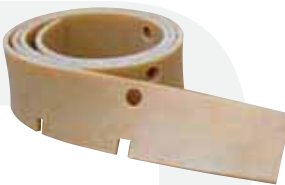

Parti di ricambio per lavasciugapavimenti Spare parts for scrubber driers

Ruote per lavasciugapavimenti Wheels for scrubber driers

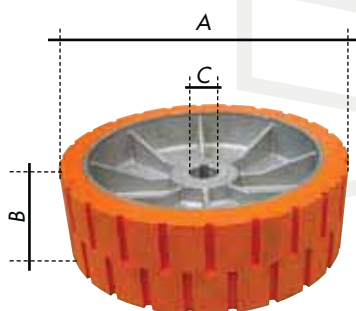

Codice Code	Descrizione Description	Diametro Diameter	Larghezza Width	Foro Hole
		A (mm)	B (mm)	C (mm)
3.006.0034	Ruota grigia Wheel - grey	150	40	12
3.006.0054	Ruota con cuscinetto e tappo - Desmopan blu Wheel with bearing and cap - Desmopan blu	80	25	8
3.006.0146	Ruota - Poliuretano 98 Sh. Wheel - Polyurethane 98 Sh.	80	24	8
3.006.0109	Ruota con cuscinetti - Poliuretano 98 Sh. Wheel with bearings - Polyurethane 98 Sh.	160	33	15
3.006.0110	Ruota con attacco a chiave - Poliuretano 98 Sh. Wheel feather key coupling - Polyurethane 98 Sh.	160	38	20
4.508.0289	Ruota - Superlastic Wheel - Superlastic	200	50	20
3.006.0139	Ruota con attacco a chiave Wheel feather key coupling	250	60	25
3.006.0114	Ruota posteriore libera Free rear wheel	250	60	39
3.006.0113	Ruota libera Free wheel	250	80	39
3.006.0112	Ruota anteriore con attacco a chiave Front wheel feather key coupling	250	80	25
3.006.0035	Ruota - Desmopan Wheel - Desmopan	80	30	12
3.006.0120	Ruota con attacco a chiave - Poliuretano Wheel feather key coupling - Polyurethane	306	92	30
3.006.0073	Ruota Wheel	255	80	25
3.006.0118	Ruota libera destra - Poliuretano 98 Sh. Free wheel right side - Polyurethane 98 Sh	160	33	17
3.006.0117	Ruota libera sinistra - Poliuretano 98 Sh. Free wheel left side - Polyurethane 98 Sh	160	33	17

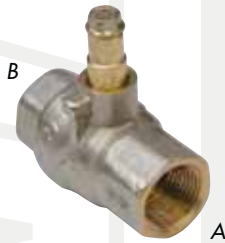

Valvole a sfera*Ball valves*

Codice Code	Descrizione Description	Attacco Coupling	Attacco Coupling
		A	B
3.099.0868	Valvola a sfera Ball valve	3/8" F	3/8" F
3.099.0333	Valvola a sfera Ball valve	1/2" F	1/2" F
3.105.0009	Valvola a sfera Ball valve	3/4" F	3/4" F

Riduttori a vite senza fine*Reduction gears*

Codice Code	Descrizione Description	Rapporto riduzione Gear Ratio	Albero (A) Shaft (A)		Foro (B) Hole (B)	
			Ø (mm)	Key (mm)	Ø (mm)	Key (mm)
3.099.0596	Riduttore RI 63 P Reduction gear RI 63 P	1/15	18	6x6	25	8x7
5.511.1756	Riduttore RI 50 P Reduction gear RI 50 P	1/15	14	5x5	24	8x7
3.099.0367	Riduttore RI 28 P Reduction gear RI 28 P	1/20	9	3x3	14	5x5
3.099.0348	Riduttore RI 40 P Reduction gear RI 40 P	1/20	11	4x4	18	6x6
5.511.1757	Riduttore RI 50 P Reduction gear RI 50 P	1/20	14	5x5	24	8x7
3.099.1482	Riduttore RI 50 P Reduction gear RI 50 P	1/20	14	5x5	24	8x7



Motori di trazione

Traction motors



Codice Code	Descrizione Description	Tensione	Potenza	Albero Shaft		Diametro	Lunghezza	Giri
		Voltage V	Power W	Ø (mm)	L (mm)	Diameter mm	Length mm	RPM
5.501.0030	Motore 36V Motor 36V	36	600	14	30	114	203.5	2000
5.501.0051	Motore 36V con freno Motor 36V with brake	36	900	14	30	114	203.5	3300
5.501.0052	Motore 24V con freno Motor 24V with brake	24	900	14	30	114	169	3200
5.501.0042	Motore 24V con freno Motor 24V with brake	24	600	14	30	114	169	3500
5.501.0032	Motore 24V Motor 24V	24	300	14	30	114	203.5	500
5.501.0071	Motore 24V Motor 24V	24	200	14	30	114	169	750

Motori per spazzola

Brush motors



Codice Code	Descrizione Description	Tensione	Potenza	Albero Shaft		Diametro	Lunghezza	Giri
		Voltage V	Power W	Ø (mm)	L (mm)	Diameter mm	Length mm	RPM
5.501.0031	Motore 36V Motor 36V	36	1000	19	40	144.5	216	2400
5.501.0013	Motore 36V Motor 36V	36	1500	19	40	144.5	216	3000
5.501.0058	Motore 24V Motor 24V	24	1250	14	30	114	213.5	4000
5.501.0003	Motore 24V Motor 24V	24	1000	14	30	114	213.5	4000
5.501.0035	Motore 24V Motor 24V	24	600	14	30	114	169	4000
5.501.0060	Motore 12V Motor 12V	12	250	14	30	101	168	1200

Motori di aspirazione*Suction motors*

Codice Code	Descrizione Description	Tensione Voltage	Potenza Power	Tipo Type
		V	W	
3.755.0096	Motore aspirazione bistadio con scarico tangenziale Two stage suction motor with tangential air waste pipe	230 50 Hz	400	A
3.755.0078	Motore aspirazione bistadio con scarico tangenziale Two stage suction motor with tangential air waste pipe	220-240 50-60 Hz	400	A
3.755.0013	Motore aspirazione bistadio con scarico tangenziale Two stage suction motor with tangential air waste pipe	230 50 Hz	1000	A
3.755.0077	Motore aspirazione bistadio con scarico tangenziale Two stage suction motor with tangential air waste pipe	12	250	A
3.755.0094	Motore aspirazione bistadio con scarico tangenziale Two stage suction motor with tangential air waste pipe	24	370	A
3.755.0039	Motore aspirazione bistadio con scarico periferico Two stage suction motor with tangential air waste pipe	24	480	A
3.755.0060	Motore aspirazione bistadio con scarico tangenziale Two stage suction motor with tangential air waste pipe	24	480	A
3.755.0056	Motore aspirazione tristadio con scarico periferico Three stage suction motor with tangential air waste pipe	24	550	B
3.755.0061	Motore aspirazione tristadio con scarico tangenziale Three stage suction motor with tangential air waste pipe	24	550	B
3.755.0062	Motore aspirazione tristadio con scarico tangenziale Three stage suction motor with tangential air waste pipe	36	600	B

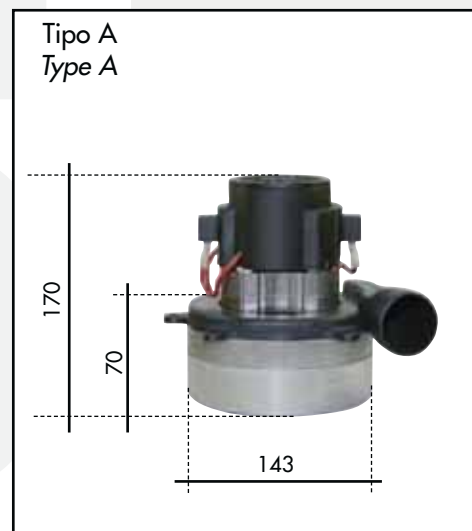

Bistadio
Double stage

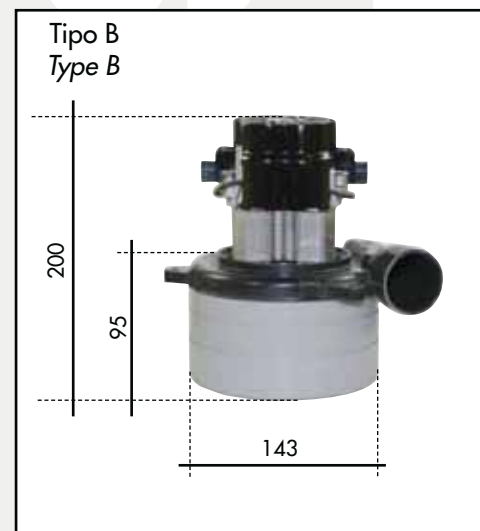

Tristadio
Triple stage

Indicatori di carica della batteria e contaore

Battery power test and hour meters



Codice Code	Descrizione Description	Tensione Voltage
		V
3.403.0117	Contaore digitale Digital hour meter	12/24/36/48
5.511.1585	Indicatore di livello di carica della batteria a led con contaore incorporato Battery power test with hour meter	12/24/36/48
3.403.0145	Indicatore di livello di carica della batteria a led con contaore incorporato Battery power test with hour meter	24/36
3.403.0188	Indicatore di livello di carica della batteria a led Battery power test	12/24/36/48
3.403.0046	Indicatore di livello di carica della batteria Battery power test	24
3.403.0178	Contaore digitale Digital hour meter	24

Interruttore a galleggiante

Floating switch



Codice Code	Descrizione Description	Diametro Diameter	Tensione Voltage
		mm	V
5.511.1228	Interruttore a galleggiante Floating switch	14	24

Elettrovalvole complete di bobina

Solenoid valves complete with coils



Codice Code	Descrizione Description	Tensione Voltage	Attacco Coupling	Attacco Coupling
		V	A	B
3.412.0024	Elettrovalvola Solenoid valve	230	1/2" M	1/2" M
3.412.0029	Elettrovalvola Solenoid valve	230	1/4" F	1/4" F
3.412.0028	Elettrovalvola Solenoid valve	12	1/4" F	1/4" F
3.412.0022	Elettrovalvola Solenoid valve	24	1/2" M	1/2" M
3.412.0034	Elettrovalvola Solenoid valve	36	1/2" M	1/2" M

Disgiuntori termici*Thermal circuit breaker*

Codice Code	Descrizione Description	Ampere
		A
3.401.0101	Disgiuntore termico <i>Thermal circuit breaker</i>	4
3.401.0102	Disgiuntore termico <i>Thermal circuit breaker</i>	8
3.401.0072	Disgiuntore termico <i>Thermal circuit breaker</i>	10
3.401.0073	Disgiuntore termico <i>Thermal circuit breaker</i>	12
3.401.0074	Disgiuntore termico <i>Thermal circuit breaker</i>	20
3.401.0119	Disgiuntore termico <i>Thermal circuit breaker</i>	25
3.401.0075	Disgiuntore termico <i>Thermal circuit breaker</i>	35
3.401.0076	Disgiuntore termico <i>Thermal circuit breaker</i>	40

Fusibili di tipo automobilistico*Automotive-type fuses*

Codice Code	Descrizione Description	Ampere
		A
3.499.0296	Fusibile di tipo automobilistico <i>Automotive-type fuse</i>	5
3.499.0297	Fusibile di tipo automobilistico <i>Automotive-type fuse</i>	10
3.499.0298	Fusibile di tipo automobilistico <i>Automotive-type fuse</i>	20
3.499.0299	Fusibile di tipo automobilistico <i>Automotive-type fuse</i>	40

Fusibili a nastro*Strip fuses*

Codice Code	Descrizione Description	Ampere	Interasse Spacing
		A	mm
3.499.0136	Fusibile a nastro <i>Strip fuse</i>	10	---
3.499.0134	Fusibile a nastro <i>Strip fuse</i>	40	---
3.499.0135	Fusibile a nastro <i>Strip fuse</i>	60	---
3.499.0030	Fusibile a nastro <i>Strip fuse</i>	80	---
3.499.0341	Fusibile a nastro <i>Strip fuse</i>	30	30
3.499.0340	Fusibile a nastro <i>Strip fuse</i>	70	30
3.499.0342	Fusibile a nastro <i>Strip fuse</i>	100	30

**WORLD
WAF**

SPAZZATRICI

SWEEPERS

SERVO

SPAZZATRICI SWEEPERS

ACCESSORI

- Batterie, caricabatterie e connettori
- Spazzole centrali e laterali
- Filtri aria motore
- Cinghie
- Filtri aria spazzatrice
- Motori a scoppio per spazzatrici

ACCESSORIES

- *Batteries, battery chargers and connectors* 158
- *Central and lateral brushes* 163
- *Air filters for engine* 164
- *Belts* 164
- *Dust filters for sweeper* 165
- *Combustion engine for sweeper* 166

pag.



Batterie, caricabatterie e connettori Batteries, battery chargers and connectors

Batteria da trazione "Piombo-Acido" a piastra piana

PB-Acid plane plate traction battery



Codice Code	Tensione Voltage	Capacità 5h 5Hr Rate	Capacità 20h 20Hr Rate	Cicli Cycles	Dimensioni (mm): Dimensions (mm):			Tipo Attacco Terminal Type
					Lung. (L)	Largh. (W)	Alt. (H)	
	Volt	Ah	Ah					
0.107.0003	6	180	240	600	245	190	255	Polo Auto Automotive Post
0.107.0001	12	60	80	600	242	175	190	Polo Auto Automotive Post

Batteria da trazione "Piombo-Acido" a piastra tubolare (corazzata)

PB-Acid tubular plate traction battery



Codice Code	Tensione Voltage	Capacità 5h 5Hr Rate	Capacità 20h 20Hr Rate	Cicli Cycles	Dimensioni (mm): Dimensions (mm):			Tipo Attacco Terminal Type
					Lung. (L)	Largh. (W)	Alt. (H)	
	Volt	Ah	Ah					
0.107.0034	6	240	265	1200	243	198	360	Polo Auto Automotive Post
0.107.0004	6	180	240	1200	242	190	275	Polo Auto Automotive Post
0.107.0014	12	85	105	1200	308	175	225	Polo Auto Automotive Post
0.107.0002	12	118	157	1200	345	170	285	Polo Auto Automotive Post

Batteria VRLA (senza manutenzione) da trazione con tecnologia Spiralcell al piombo puro

VRLA maintenance free battery with Spiralcell technology



Codice Code	Tensione Voltage	Capacità 5h 5Hr Rate	Capacità 20h 20Hr Rate	Cicli Cycles	Dimensioni (mm): Dimensions (mm):			Tipo Attacco Terminal Type
					Lung. (L)	Largh. (W)	Alt. (H)	
	Volt	Ah	Ah					
0.107.0050	12	52	55	400-500	254	175	200	Polo Auto + Perno M6 Automotive Post & Stud M6
0.107.0054	12	72	75	400-500	325	165	238	Polo Auto + Perno M6 Automotive Post & Stud M6

- * Ricarica veloce ed elevato raggio di azione
- * Maggiore produttività, grazie all'elevata capacità giornaliera di pulizia.
- * Tecnologia "verde" all'avanguardia, duratura, nel rispetto di ambiente, salute e sicurezza
- * A tenuta stagna, non richiede manutenzione, facile da gestire
- * Estremamente resistente alle vibrazioni, anche in presenza di fondo difficile
- * Dura sino a due volte di più

- * Rapid recharging and a greater action radius
- * Increased productivity through enhanced daily cleaning capacity
- * Cutting-edge, sustainable green technology in the area of environment, health and safety (EH&S)
- * Spill-proof, absolutely maintenance-free and easy to handle
- * Extremely vibration-resistant even over difficult terrain
- * Up to twice the customary service life

Batteria VRLA (senza manutenzione) da trazione con tecnologia "GEL"

GEL technology maintenance free battery



Codice Code	Tensione Voltage	Capacità 5h 5Hr Rate	Capacità 20h 20Hr Rate	Cicli Cycles	Dimensioni (mm): Dimensions (mm):			Tipo Attacco Terminal Type
					Lung. (L)	Largh. (W)	Alt. (H)	
	Volt	Ah	Ah		Lung. (L)	Largh. (W)	Alt. (H)	
0.107.0033	6	180	240	700-800	242	190	275	Polo Auto Automotive Post
0.107.0063	12	105	120	700-800	243	198	360	Polo Auto Automotive Post

Batteria da trazione Piombo-Acido "elementi a cassone"

PB-Acid traction battery box



Codice Code	Tensione Voltage	Capacità 5h 5Hr Rate	Capacità 10h 10Hr Rate	Cicli Cycles	Dimensioni (mm): Dimensions (mm):			Tipo Attacco Terminal Type
					Lung. (L)	Largh. (W)	Alt. (H)	
	Volt	Ah	Ah		Lung. (L)	Largh. (W)	Alt. (H)	
0.107.0008	24	500	585	1200	610	410	535	Polo Auto Automotive Post
0.107.0009	36	360	421	1200	610	525	510	Polo Auto Automotive Post
0.107.0010	36	525	614	1200	610	610	550	Polo Auto Automotive Post

Batteria VRLA (senza manutenzione) da trazione con tecnologia "GEL"

"elementi a cassone"

VRLA maintenance free traction battery box - GEL



Codice Code	Tensione Voltage	Capacità 5h 5Hr Rate	Capacità 20h 20Hr Rate	Cicli Cycles	Dimensioni (mm): Dimensions (mm):			Tipo Attacco Terminal Type
					Lung. (L)	Largh. (W)	Alt. (H)	
	Volt	Ah	Ah		Lung. (L)	Largh. (W)	Alt. (H)	
0.107.0011	24	400	468	800	610	410	535	Polo Auto Automotive Post
0.107.0012	36	320	374	800	610	525	510	Polo Auto Automotive Post
0.107.0013	36	400	468	800	610	610	550	Polo Auto Automotive Post

Coppia poli conici per batteria

Automotive post terminal (couple)



Codice Code	Attacco Coupling	Quantità Quantity
0.107.0031	M6 M	1 pos. 1 neg.
0.107.0047	M8 M	1 pos. 1 neg.

Caricabatterie universali programmabili ad alta frequenza*Universal programmable high-frequency battery charger*

Codice Code	Voltaggio batteria Battery Voltage	Capacità di carica Charging current	Dimensioni (mm): Dimensions (mm):			Parametri Operating parameters	
			Lung. (L)	Largh. (W)	Alt. (H)	V	Hz
0.108.0001	12/24	12	205	255	140	220/240	50/60
0.108.0002	12/24	30	404	355	195	220/240	50/60
0.108.0003	24/36	60	505	485	245	220/240	50/60

Come scegliere il caricabatteria adatto.

La corretta capacità di carica del caricabatteria si determina calcolando l'11% della capacità in 5h della batteria da ricaricare

Esempio: batteria 0.107.0002 con capacità 5h = 118 Ah ; $118 \times 11\% = 12,8$ - Il caricabatteria adatto è il 0.108.0001 che ha capacità di carica 12A.

How to choose the right charger.

The correct charge capacity of the battery charger is determined by calculating the 11% of the 5 hours rate of the battery to be recharged

Example: 0.107.0002 battery with 5 hours rate = 118 Ah: $118 \times 11\% = 12.8$ - The right charger is 0.108.0001, whose charge capacity is 12A.

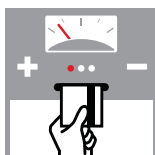
Smartcard per configurazione caricabatteria*Smartcard for battery charger setting*

Codice Code	Per caricare batteria: Suitable to charge battery:	Curva di carica Charging curve	Ampere	Volts
0.108.0006	Cassone 0.107.0008 Piombo-Acido Box 0.107.0008 Pb-Acid	IUIa-Acd	60	24
0.108.0007	Cassone 0.107.0011 GEL Box 0.107.0011 GEL	IUIa-PzVGel	50	24
0.108.0008	Cassone 0.107.0009 Piombo-Acido Box 0.107.0009 Pb-Acid	IUIa-Acd	50	36
0.108.0009	Cassone 0.107.0012 - 0.107.0013 GEL Box 0.107.0012 - 0.107.0013 GEL	IUIa-PzVGel	50	36
0.108.0010	Cassone 0.107.0010 Piombo-Acido Box 0.107.0010 Pb-Acid	IUIa-Acd	60	36

Caricabatterie rapido*Booster battery charger*

Codice Code	Descrizione Description	Voltaggio batteria Battery Voltage	Capacità di carica Charging current	Dimensioni (mm): Dimensions (mm):			Parametri Operating parameters	
		Volt	A	Lung. (L)	Largh. (W)	Alt. (H)	V	Hz
0.108.0051	CBHF2	12	30	300	180	100	220/240	50/60

Caricabatterie a bordo*On-board battery charger*

Codice Code	Descrizione Description	Voltaggio batteria Battery Voltage	Capacità di carica Charging current	Dimensioni (mm): Dimensions (mm):			Parametri Operating parameters	
		Volt	A	Lung. (L)	Largh. (W)	Alt. (H)	V	Hz
5.511.1641	CBHF1-SM	24	12	220	130	55	220/240	50/60
0.108.0031	CBHD1 - IUIA-ACD	24	10	145	130	60	220/240	50/60
0.108.0042	CBHD1 - IUIA-GEL	24	10	170	130	60	220/240	50/60
5.511.1800	CBHD1	12	6	130	110	60	220/240	50/60
0.108.0048	CBHF1-SM	24	12	200	125	80	220/240	50/60
0.108.0049	CBHF2	24	25	250	160	70	220/240	50/60

Cavo per caricabatterie a bordo*Power cord for on-board battery charger*

Codice Code	Lunghezza cavo Cable length	Sezione cavo Wire section	Tipo di spina Plug type
	mt		
0.108.0025	1,5	3 x 0.75 mm ²	EU SHUKO
0.108.0028	1,5	3 x 0.75 mm ²	AUSTRALIA
0.108.0027	1,5	3 x 0.75 mm ²	UK
0.108.0026	1,5	3 x AWG16	USA

Trasferimento dati per caricabatterie*Battery charger data transfer*

Codice Code	Descrizione Description	Per caricabatteria For battery charger
0.108.0053	Software lettura dati per caricabatterie Data reader software for battery charger	0.108.0045 - CBHD1
0.108.0050	Cavo seriale per trasmissione dati da caricabatteria a PC Serial cable for	0.108.0045 - CBHD1

Cavi, morsetti e cappucci per batterie*Cables, cable terminals and terminals cover for batteries*

Codice Code	Descrizione Description
3.405.0118	Morsetto negativo ad occhio <i>Eyelet cable terminal - negative</i>
3.405.0119	Morsetto positivo ad occhio <i>Eyelet cable terminal - positive</i>
3.405.0046	Morsetto negativo per terminale conico <i>Cable terminal for automotive post battery terminal - negative</i>
3.405.0047	Morsetto positivo per terminale conico <i>Cable terminal for automotive post battery terminal - positive</i>
3.405.0113	Cappuccio nero negativo <i>Black terminal cover - negative</i>
3.405.0114	Cappuccio rosso positivo <i>Red terminal cover - positive</i>
5.511.0561	Cavo completo di morsetto per polo auto e cappuccio <i>Cable assembly with automotive post terminals and terminal covers</i>

Connettori, maniglie per connettori e contatti*Connectors, connector handles and contacts*

Codice Code	Descrizione Description	Voltaggio Voltage	Corrente A
		V	A
3.099.0808	Impugnatura universale con viti <i>Universal connector handle with screws</i>	12-24	50
3.499.0029	Connettore completo di contatti <i>Connector with contacts</i>	12-24	50
3.499.0313	Contatto <i>Contact</i>	12-24	50
3.499.0246	Connettore <i>Connector</i>	24-36	80
3.499.0249	Contatto per cavi di sezione 16 mm <i>Contact for cables 16 mm diameter</i>	24-36	80
3.499.0247	Contatto per cavi di sezione 25 mm <i>Contact for cables 25 mm diameter</i>	24-36	80
3.499.0248	Maniglia con viti <i>Connector handle with screws</i>	24-36	80
3.499.0036	Connettore <i>Connector</i>	24-36	160
3.499.0051	Connettore grigio <i>Grey connector</i>	36	160
3.499.0352	Contatto <i>Contact</i>	24-36	160
3.499.0037	Impugnatura <i>Connector handle</i>	24-36	160

Spazzole centrali in PPL*PPL central brushes*

Codice Code	Descrizione Description	A	B	Attacco Coupling
		mm	mm	
0.942.0036	Spazzola centrale Central brush	500	250	B
0.915.0382	Spazzola centrale in nylon Nylon central brush	700	280	B
0.915.0017	Spazzola centrale in nylon Nylon central brush	700	280	C
0.915.0653	Spazzola centrale in PPL a doppia sezione (0.4-0.7 mm)	700	280	C
0.915.0370	Spazzola centrale in PPL PPL central brush	700	280	A
0.915.0005	Spazzola centrale in PPL con fusto Moplen PPL central brush with Moplen body	700	280	D
0.915.0642	Spazzola centrale in PPL con fusto Moplen PL central brush with Moplen body	700	280	C
0.915.0006	Spazzola centrale in PPL con fusto Moplen PPL central brush with Moplen body	700	280	D
0.915.0010	Spazzola centrale in PPL con fusto Moplen PPL central brush with Moplen body	700	280	D

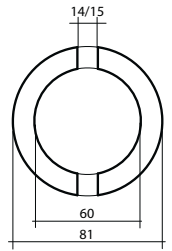
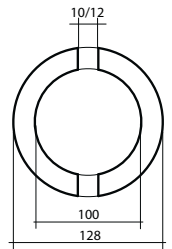
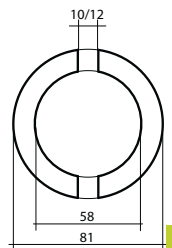
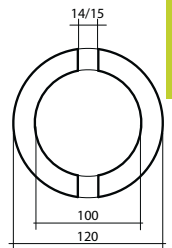
Attacco tipo **A**
Coupling type **A**Attacco tipo **B**
Coupling type **B**Attacco tipo **C**
Coupling type **C**Attacco tipo **D**
Coupling type **D****Spazzole centrali speciali***Special type central brushes*

Codice Code	Descrizione Description	A	B	Attacco Coupling
		mm	mm	
0.915.0641	Spazzola centrale misto acciaio con fusto in cartone Mixed steel central brush with cardboard body	700	280	C
0.915.0640	Spazzola centrale misto acciaio con fusto Moplen Mixed steel central brush with Moplen body	700	280	D
0.915.0371	Spazzola centrale tampico Tampico central brush	700	280	A

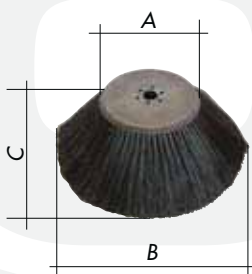
Spazzole laterali in PPL*PPL side brushes*

Codice Code	Descrizione Description	A	B	C
		mm	mm	mm
0.942.0037	Spazzola laterale PPL PPL side brush	150	360	120
0.915.0003	Spazzola laterale PPL PPL side brush	185	380	145

Spazzole laterali speciali*Special type side brushes*

Codice Code	Descrizione Description	A	B	C
		mm	mm	mm
0.915.0004	Spazzola laterale misto acciaio Mixed steel side brush	185	380	145

Filtri aria per motore

Air filters for engine

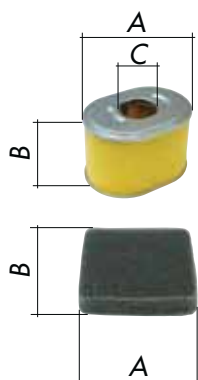

Codice Code	Descrizione Description	A	B	C
		mm	mm	Ø mm
0.915.0244	Filtro aria a cartuccia per motore Air filter cartridge	100	70	33
0.915.0254	Filtro aria in spugna per motore Foam air filter	90	75	-

Cinghie

Belts

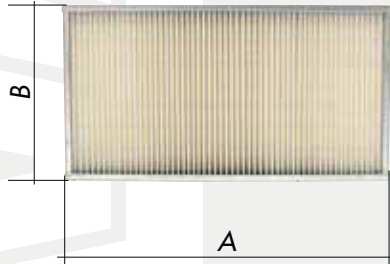

Codice Code	Descrizione Description	Sezione Section	Sviluppo Length	Z
		mm	mm	
0.904.0081	Cinghia tonda Round belt	8	1015	---
0.904.0154	Cinghia tonda Round belt	10	575	---
0.915.0025	Cinghia tonda Round belt	10	600	---
0.915.0026	Cinghia tonda Round belt	10	800	---
0.915.0027	Cinghia tonda Round belt	8	900	---
0.915.0029	Cinghia tonda Round belt	8	700	---
0.915.0038	Cinghia tonda Round belt	8	775	---
0.915.0040	Cinghia tonda Round belt	9	1035	---
0.904.0178	Cinghia dentata Toothed belt	10	1620	64
0.915.0186	Cinghia dentata Toothed belt	9.3	875	SPZ-X
0.915.0193	Cinghia dentata Toothed belt	9.7	643	SPZ 630
0.904.0082	Cinghia trapezoidale V belt	10	750	---
0.904.0103	Cinghia trapezoidale V belt	10	785	---
0.915.0028	Cinghia trapezoidale V belt	10	975	---
0.915.0039	Cinghia trapezoidale V belt	9.7	1950	---
0.942.0005	Cinghia trapezoidale V belt	10	1400	---
0.915.0041	Cinghia trapezoidale V belt	9.7	735	---
0.915.0208	Cinghia trapezoidale V belt	9.5	1950	---
0.904.0153	Cinghia Poly V Poly V belt	24	660	---

Filtri a pannello per polveri*Panel dust filters*

Codice Code	Descrizione Description	Potere filtrante Filtering capacity	A	B
		µm	mm	mm
0.904.0080	Filtro standard a pannello Standard panel filter	5	460	250
0.904.0139	Filtro standard a pannello Standard panel filter	5	640	400
0.915.0387	Filtro in poliestere a pannello Polyester panel filter	20	740	220
0.915.0008	Filtro in carta a pannello Paper panel filter	5	550	220
0.915.0001	Filtro in carta a pannello Paper panel filter	5	740	220
0.915.0380	Filtro in poliestere a pannello Polyester panel filter	3	550	220
0.915.0009	Filtro in poliestere a pannello Polyester panel filter	5	550	220
0.915.0002	Filtro in poliestere a pannello Polyester panel filter	5	740	220

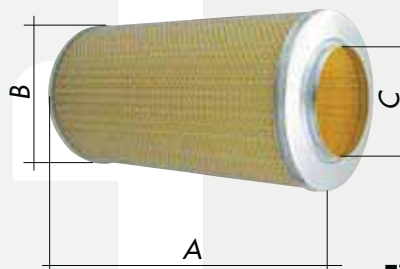
**Filtri a cartuccia per polveri***Cartridge dust filters*

Codice Code	Descrizione Description	Potere filtrante Filtering capacity	A	B	C
		µm	mm	mm	Ø mm
0.915.0012	Filtro in carta a cartuccia Paper cartridge filter	5	365	190	118
0.915.0013	Filtro in poliestere a cartuccia Polyester cartridge filter	5	365	190	118

Motore a scoppio HONDA

HONDA combustion engine



Codice Code	Sigla Sign	Tipo Type	Potenza Power		Cilindrata Displacement	Giri/min RPM	Alimentazione Fuel	Capacità serbatoio Fuel tank capacity	Colore Colour	Tipo attacco Coupling type
			Hp	kW						
3.600.0020	GC160	Monocilindrico 4 tempi raffreddato ad aria Aircooled 4-stroke single-cylinder	4,6	3,4	160	3600	Benzina senza piombo Unleaded fuel	1,8	Rosso Red	A

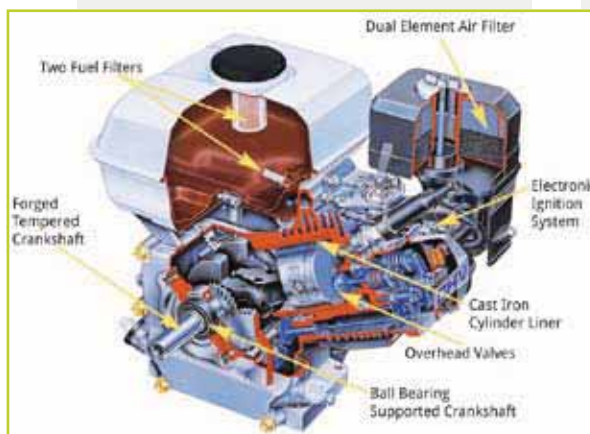
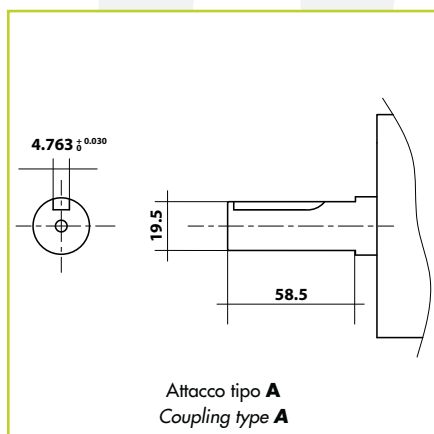



VAPOR
WATER

GENERATORI DI VAPORE

STEAM GENERATORS

SERVICES

GENERATORI DI VAPORE STEAM GENERATORS

**Accessori e ricambi
per generatori di vapore
sono disponibili
su richiesta**

***Accessories and spare
parts for steam generators
are available on request***



WALF

NEBULIZZATORI

SPRAYERS

SEERVO

NEBULIZZATORI SPRAYERS

ACCESSORI

- Nebulizzatori completi
- Lance
- Tubi flessibili, raccordi, ugelli e ricambi vari

ACCESSORIES

- Complete sprayers
- Lances
- Flexible hoses, couplings, nozzles and various spare parts

pag.

172

173

174



Per completare le possibilità di distribuzione del prodotto chimico e permetterne la migliore applicabilità ed efficacia i nebulizzatori sono la soluzione ideale in quanto a estensione di distribuzione, versatilità di utilizzo ed economia di dosaggio.

Si dividono in tre diverse categorie: a precompressione, a ricarica pneumatica ed a carica pneumatica continua.

I **nebulizzatori a precompressione** non necessitano di alcun compressore separato, in quanto si usa la pompa manuale integrata per portare in compressione il contenitore e nebulizzare il prodotto. Lavorano a basse pressioni, si utilizzano materiali plastici per la trasportabilità, la leggerezza e per l'ottima resistenza agli agenti chimici, grazie anche alle tenute in FPM (Viton).

I **nebulizzatori a ricarica pneumatica** necessitano del collegamento ad un compressore per ricaricare la tanica e quindi permettere la nebulizzazione del prodotto senza il compressore collegato. Lavorano ad elevate pressioni, per questo si utilizzano contenitori in metallo o in acciaio INOX di grandi dimensioni per permettere una maggiore autonomia di lavoro.

I **nebulizzatori a carica pneumatica** continua (schiumogeni) necessitano del collegamento permanente ad un compressore, in questo modo l'aria viene miscelata al prodotto chimico e si produce una schiuma voluminosa che aderisce alle superfici da trattare: con meno prodotto chimico si lavora una superficie più ampia o uno sporco difficile da sottoporre all'aggressione chimica (soffitti, pareti inclinate e/o scivolose). Lavorano ad elevate pressioni, per questo si utilizzano contenitori in metallo o in acciaio INOX di grandi dimensioni per permettere una maggiore autonomia di lavoro.

In order to complete the chemical products supply and to allow a better applicability and effectiveness, the sprayers are the perfect solution when supply wideness,

use versatility and dosage saving are taken into consideration.



They are split into three different categories: pre-compression, pneumatic charge and continuous pneumatic charge.

Pre-compression sprayers don't need any separate air compressor, because the integrated manual pump is used to compress the tank and vaporize the product. They work at low pressures, they use plastic materials for easy moving, lightness and perfectly resistant to chemical products, thanks also to FPM seals (Viton).

Pneumatic charge sprayers need to be connected to an air compressor to charge the tank and allow the product vaporization without the connection to the air compressor. They work at high-pressures and so they use capacious steel or stainless steel tanks to allow a greater working autonomy.

Continuous pneumatic charge foam sprayers need a permanent connection to an air compressor; in this way air mixes with the chemical product producing a soft and voluminous foam that persists on surfaces: with a little chemical product, it is possible to treat wider areas or tough dirt (also on ceilings, inclined and/or slippery walls).

They work at high-pressure and so they use capacious steel or stainless steel tanks to allow a greater working autonomy.

Codice Code	Modello Model	Prodotto Product	Tipo Type	Volume contenitore Capacity litri litres	Tipo di ricarica Recharging	Pressione di esercizio Working pressure bar	Categoria Category	Peso con imballo Kg	Single packaging weight lbs	Imballo Packaging cm	Pezzi x pallet Pieces for pallet N°	Dimensioni pallet Pallet dimensions L x P x h
0.006.0007	FOAMJET SV24	Schiumogeno Foam sprayer	Verniciato Painted	24	Pneumatica Continua Air operating	6	Carrellato Trolley	17	38	34x34 h 82	18	102x102x215
0.006.0009	FOAMJET SX24	Schiumogeno Foam sprayer	Inox Stainless steel	24	Pneumatica Continua Air operating	6	Carrellato Trolley	13	29	34x34 h 82	18	102x102x215
0.006.0008	FOAMJET SV50	Schiumogeno Foam sprayer	Verniciato Painted	50	Pneumatica Continua Air operating	6	Carrellato Trolley	27	60	47x47 h 107	12	141x107x205
0.006.0010	FOAMJET SX50	Schiumogeno Foam sprayer	Inox Stainless steel	50	Pneumatica Continua Air operating	6	Carrellato Trolley	20	44	47x47 h 107	12	141x107x205
0.006.0002	SPRAY NV24	Nebulizzatore Sprayer	Verniciato Painted	24	Pneumatica Pneumatic	6	Carrellato Trolley	17	38	34x34 h 82	18	102x102x215
0.006.0004	SPRAY NX24	Nebulizzatore Sprayer	Inox Stainless steel	24	Pneumatica Pneumatic	6	Carrellato Trolley	13	29	34x34 h 82	18	102x102x215
0.006.0003	SPRAY NV50	Nebulizzatore Sprayer	Verniciato Painted	50	Pneumatica Pneumatic	6	Carrellato Trolley	27	60	47x47 h 107	12	141x107x205
0.006.0005	SPRAY NX50	Nebulizzatore Sprayer	Inox Stainless steel	50	Pneumatica Pneumatic	6	Carrellato Trolley	20	44	47x47 h 107	12	141x107x205
0.006.0012	COMPREX NP10	Nebulizzatore Sprayer	Plastica Plastic	10,75	Manuale Manual	3	Spallabile Belt	2,3	5	22x22 h 57	70	120x80x235
0.006.0011	COMPREX NP12	Nebulizzatore Sprayer	Plastica Plastic	14,85	Manuale Manual	3	Carrellato Trolley	4,9	11	38x38 h 55	24	120x80x233

Lancia con impugnatura

Lance with handle



A

Kit di manutenzione

Maintenance kit

Codice/Code: 0.906.0019



Codice Code	Lunghezza Length	Entrata Inlet	Ugello Nozzle	Pressione Pressure			Portata Flow rate		Temperatura Temperature		Adatto per: Suitable for:		
				bar	psi	MPa	l/m	GPM	°C	°F	Foamjet	Spray	Complex
	mm	A											
0.906.0030	600	G 1/4" F	X	25	363	2,5	30	7.93	50	122	X	X	
0.906.0031	900	G 1/4" F	X	25	363	2,5	30	7.93	50	122	X	X	
0.906.0032	1200	G 1/4" F	X	25	363	2,5	30	7.93	50	122	X	X	
0.906.0033	1500	G 1/4" F	X	25	363	2,5	30	7.93	50	122	X	X	
0.906.0034	2000	G 1/4" F	X	25	363	2,5	30	7.93	50	122	X	X	

Lancia inox con impugnatura

Stainless steel lance with handle



A

Kit di manutenzione

Maintenance kit

Codice/Code: 0.906.0019



Codice Code	Lunghezza Length	Entrata Inlet	Ugello Nozzle	Pressione Pressure			Portata Flow rate		Temperatura Temperature		Adatto per: Suitable for:		
				bar	psi	MPa	l/m	GPM	°C	°F	Foamjet	Spray	Complex
	mm	A											
0.906.0035	600	G 1/4" F	X	25	363	2,5	30	7.93	50	122	X	X	
0.906.0036	900	G 1/4" F	X	25	363	2,5	30	7.93	50	122	X	X	
0.906.0037	1200	G 1/4" F	X	25	363	2,5	30	7.93	50	122	X	X	
0.906.0038	1500	G 1/4" F	X	25	363	2,5	30	7.93	50	122	X	X	
0.906.0039	2000	G 1/4" F	X	25	363	2,5	30	7.93	50	122	X	X	

Impugnatura per lancia

Lance handle



A

B

Kit di manutenzione

Maintenance kit

Codice/Code: 0.906.0019



Codice Code	Entrata Inlet	Uscita Outlet	Pressione Pressure			Portata Flow rate		Temperatura Temperature		Adatto per: Suitable for:		
	A	B	bar	psi	MPa	l/m	GPM	°C	°F	Foamjet	Spray	Complex
0.906.0024	G 1/4" F	G 1/4" F	25	363	2,5	70	18,5	50	122	X	X	

Raccordo rapido

Screw coupling



Codice Code	Entrata Inlet	Uscita Outlet
	A	B
0.906.0088	G 1/4" M	Rapido a baionetta Quick bayonet

Riduzione per lancia con impugnatura

Reduction nipple for lance with handle



Codice Code	Entrata Inlet	Uscita Outlet	Adatto per: Suitable for:		
			Foamjet	Spray	Comprex
	A	B			
0.906.0025	G 1/2" M	G 1/4" F	X	X	

Portaugello in plastica

Plastic nozzle holder



Codice Code	Entrata Inlet	Uscita Outlet	Adatto per: Suitable for:		
			Foamjet	Spray	Comprex
	A	B			
0.906.0051	Ø 12,5 mm	G 1/2" M	X	X	

Tubo in PVC retinato con raccordi

PVC foam hose with bayonet coupling



Codice Code	Diametro Diameter	Lunghezza Length	Tipo di attacco Coupling type	Adatto per: Suitable for:		
				Foamjet	Spray	Comprex
		mt				
0.906.0082	8 x 13	10	Rapido a baionetta Quick bayonet	X*	X*	
0.906.0083	8 x 13	15	Rapido a baionetta Quick bayonet	X*	X*	

* con raccordo rapido 0.906.00888 - * with screw coupling 0.906.0088

Tubo Rilsan a spirale

Flexible hose



Codice Code	Diametro Diameter	Lunghezza Length	Tipo di attacco Coupling type	Adatto per: Suitable for:		
				Foamjet	Spray	Comprex
		mt				
0.906.0084	8 x 6	10	Girevole -1/4" M - 1/4" M Pivoting -1/4" M - 1/4" M	X	X	

Testina completa di ugello in ottone*Complete nozzle holder with brass nozzle*

Codice Code	Entrata Inlet	Adatto per: Suitable for:		
		Foamjet	Spray	Comprex
0.906.0015	G 1/4" F	X	X	

Ugelli schiumogeni in ottone*Brass nozzle*

Codice Code	Attacco Thread	Angolo Angle	Fattore portata Capacity size	Adatto per: Suitable for:		
				Foamjet	Spray	Comprex
0.906.0047	G 1/8" M	60°	10	X	X	

Ugello in ottone a pastiglia*Brass nozzle*

Codice Code	Angolo Angle	Fattore portata Capacity size	Adatto per: Suitable for:		
			Foamjet	Spray	Comprex
0.906.0045	40°	04	X	X	
0.906.0010	60°	04	X	X	

Ugelli in plastica*Plastic nozzle*

Codice Code	Angolo Angle	Fattore portata Capacity size	Adatto per: Suitable for:		
			Foamjet	Spray	Comprex
0.906.0048	110°	03	X	X	

Filtro inox per ugelli*Stainless steel filter for nozzle*

Codice Code	Guarnizione Gasket	Trama Mesh
0.906.0056	Viton	50

Testina completa di ugello in ottone

Complete nozzle holder with brass nozzle



Codice Code	Attacco Thread	Attacco Thread	Adatto per: Suitable for:		
			Foamjet	Spray	Comprex
0.906.0044	G 1/2" M	G 1/8" M	X	X	

Ugello per testina 0.906.0044

Brass nozzle for nozzle holder 0.906.0044



Codice Code	Attacco Thread	Angolo Angle	Fattore portata Capacity size
			A
0.906.0047	G 1/8" M	60°	10

Manometro

Manometer



Codice Code	Attacco Thread	Diametro Diameter	Pressione Pressure			Adatto per: Suitable for:		
			bar	psi	MPa	Foamjet	Spray	Comprex
0.906.0079	G 1/8" M	40	0-12	0-174	0-1,2	X	X	
0.906.0016	G 1/4" M	50	0-12	0-174	0-1,2	X	X	

Regolatore di pressione

Pressure regulating valve



Codice Code	Entrata Inlet	Uscita Outlet	Pressione Pressure			Adatto per: Suitable for:		
			bar	psi	MPa	Foamjet	Spray	Comprex
0.906.0075	G 1/4" F	G 1/4" F	0-8	0-116	0-0,8	X	X	

Raccordo rapido per regolatore di pressione 0.906.0075

Screw coupling for pressure regulating valve 0.906.0075



Codice Code	Entrata Inlet	Uscita Outlet
		B
0.906.0088	G 1/4" M	Rapido a baionetta Quick bayonet

Tappo con valvola

Plug with valve



Codice Code	Attacco Thread	Valvola Overload valve	Pressione valvola Valve pressure			Tipo Type	Adatto per: Suitable for:		
			bar	psi	MPa		Foamjet	Spray	Comprex
0.906.0003	G 1" M	X	7	102	0,7	Ottone Brass	X	X	
0.906.0023	G 1" M	X	4	58	0,4	Ottone Brass	X	X	
0.917.0001	G 1" M					Plastica Plastic	X	X	

Valvola di sicurezza

Safety relief valve



Codice Code	Attacco Thread	Taratura Max air pressure			Adatto per: Suitable for:		
		bar	psi	MPa	Foamjet	Spray	Comprex
0.906.0076	G 1/8" M	8	116	0,8	X	X	

Rubinetto

Tap



Codice Code	Entrata Inlet	Uscita Outlet	Tipo Type	Adatto per: Suitable for:		
				Foamjet	Spray	Complex
	A	B				
0.906.0070	G 1/4" M	Rapido a baionetta Quick bayonet	Rapido a corsoio	X	X	



Codice Code	Entrata Inlet	Uscita Outlet	Tipo Type	Adatto per: Suitable for:		
				Foamjet	Spray	Complex
	A	B				
0.906.0071	G 1/4" F	G 1/4" M	Rapido a sfera Ball valve	X	X	



Codice Code	Entrata Inlet	Uscita Outlet	Tipo Type	Adatto per: Suitable for:		
				Foamjet	Spray	Complex
	A	B				
0.906.0072	G 1/4" M	G 1/4" M	Per regolazione detergente Chemical metering valve	X	X	



Codice Code	Entrata Inlet	Uscita Outlet	Tipo Type	Adatto per: Suitable for:		
				Foamjet	Spray	Complex
	A	B				
0.906.0073	G 1/8" M	Rilsan	Rubinetto di sfianto	X	X	

Kit ruota singola completa con attacchi

Kit single wheel complete with connection



Codice Code	Ø Foro (mm) Hole Ø (mm)	Ø Ruota (mm) Wheel Ø (mm)	Versione 24 lt Model 24 lt	Versione 50 lt Model 50 lt	Adatto per: Suitable for:		
					Foamjet	Spray	Complex
	A	B					
6.005.0337	15,5	120	X		X	X	
6.005.0338	20,5	200		X	X	X	

WORLDWIDE

TAGLIO LEGNO

WOOD CUTTING

SERVICES



Codice/Code 7.199.1067

NEW

Nel nuovo catalogo "STARTEK" potrete trovare una gamma completa di prodotti per il taglio legno, di elettroutensili e di pompe sommerse.

In the new "STARTEK" catalogue you can find a complete range of products for wood cutting, power tools and submersible pumps.



Codice Code	Descrizione Description	Tipo Type	Ø Lama Ø Blade [mm]	Larghezza denti Teeth width [mm]	Nr. denti Teeth Nr.	Ø Foro Ø Hole [mm]	Utilizzo: Suitable for :	
							Alluminio Aluminum	Legno Wood
3.020.0010	DISCO HSS - HSS DISC BLADE	HSS	210	1,4	80	30		X
3.020.0006	DISCO HSS - HSS DISC BLADE	HSS	300	1,6	80	30		X
3.020.0019	DISCO HSS - HSS DISC BLADE	HSS	315	1,8	56	30		X
3.020.0009	DISCO WIDIA - WIDIA DISC BLADE	Widia	200	1,5	20	30		X
3.020.0011	DISCO WIDIA - WIDIA DISC BLADE	Widia	210	1,5	32	30		X
3.020.0004	DISCO WIDIA - WIDIA DISC BLADE	Widia	250	2,5	80	30	X	X
3.020.0036	DISCO WIDIA - WIDIA DISC BLADE	Widia	254	2,8	40	30		X
3.020.0016	DISCO WIDIA - WIDIA DISC BLADE	Widia	315	2,8	48	30		X
3.020.0032	DISCO TEFLONATO - TEFLON DISC BLADE	Teflon	300	2,8	48	30		X

Codice Code	Descrizione Description	Tipo Type	Ø Lama Ø Blade [mm]	Spessore Thickness [mm]	Ø Foro Ø Hole [mm]	Utilizzo: Suitable for :
3.021.0001	DISCO DIAMANTATO . DIAMOND BLADE DISC	Diamante Diamond	180	2	30	Piastrelle Tiles
3.021.0002	DISCO DIAMANTATO . DIAMOND BLADE DISC	Diamante Diamond	200	2.5	30	Piastrelle Tiles

WORLDWIDE

PRODOTTI CHIMICI

CHEMICAL PRODUCTS

SEEVER

PRODOTTI CHIMICI CHEMICAL PRODUCTS

PRODOTTI CHIMICI

- Detergenti, igienizzanti e per manutenzione
- Abbattitori di schiuma, anticalcare, acidi e prodotti chimici multiuso

CHEMICAL PRODUCTS

- *Detergents, sanitising and maintenance chemical products* 182
- *Foam suppressors, anti-scale, acids and multipurpose chemical products* 187

pag.



Nel catalogo "Chemical Line" di Lavor potrete trovare una gamma completa di prodotti chimici per la pulizia professionale.

In the "Chemical Line" catalogue of Lavor you can find a complete range of chemical products for professional cleaning.



Codice/Code 7.199.0557

Tecnologia / Technology

T1		mop carrello strizzatore <i>manual cleaning</i>	T5		lavasuperficie a vapore <i>steam cleaner</i>
T2		nebulizzatore <i>sprayer</i>	T6		monospazzola <i>single disc machine</i>
T3		lavamoquette <i>carpet cleaner</i>	T7		lavapavimenti <i>floor scrubber-drier</i>
T4		idropulitrice <i>high-pressure cleaner</i>			





















Prodotto Product















Tecnologia Technology

















Prodotto Product













Tecnologia Technology













	codice code	T1	T2	T3	T4	T5	T6	T7		codice code	T1	T2	T3	T4	T5	T6	T7
LCN-800F	3.697.0023								CAR	0.010.0030							
LCN-800	3.697.0024								TEXIL	0.010.0031							
LCN-680AL	3.697.0025								LC-PREFOAM	3.697.0036							
LCN-650	3.697.0026								LC-PRECAL	3.697.0037							
LCN-640WM	3.697.0027								DESCALER	0.010.0032							
LCB-900WR	3.697.0030								MUSCAL	0.010.0033							
LCB-740F	3.697.0031								STEAM PRECAL	0.010.0028							
LCN-600SVF	3.697.0033								STEAM LIQUID PRECAL	0.010.0036							
LCN-700	3.697.0035								HYGIENIC PARFUM	0.010.0035							
SPRAYER	0.010.0029								SCRUBBER HYGIENIC PARFUM	0.010.0034							







ARTICOLO MODEL	DESCRIZIONE DESCRIPTION	PROPRIETA' PROPERTIES	ISTRUZIONI PER L'USO: USE:	
LCN-800F codice/code 3.697.0023  Ph 7.8 - 8.2 1,000 g/ml  5000 ml x 4 pz.	DETERGENTE IGIENIZZANTE NON PROFUMATO FRAGRANCE-FREE SANITI- SING DETERGENT	Elimina i cattivi odori, combatte la proliferazione batterica, i microrganismi dannosi, i funghi e le muffe. Contiene sali quaternari d'ammonio. <i>Destroys unpleasant odours, fights the proliferation of bacteria, harmful micro-organisms, fungi and moulds. Contains quaternary ammonium salts.</i>	Per tutti i tipi di superfici dure, diluire dall'1 al 3%. In caso di contaminazioni tenaci e cattivi odori aggressivi diluire fino al 6%. <i>On all types of hard surface, dilute from 1 to 3%. In the case of tenacious contaminations and aggressive unpleasant odours, dilute up to 6%.</i>	T1  T2  T3  T5  T7 
LCN-800 codice/code 3.697.0024  Ph 7.8 - 8.2 1,000 g/ml  5000 ml x 4 pz.	DETERGENTE IGIENIZZANTE NON PROFUMATO FRAGRANCE SANITISING DETERGENT	Elimina i cattivi odori, combatte la proliferazione batterica, i microrganismi dannosi, i funghi e le muffe. Contiene sali quaternari d'ammonio. Lascia un profumo fresco e persistente. <i>Destroys unpleasant odours, fights the proliferation of bacteria, harmful micro-organisms, fungi and moulds. Contains quaternary ammonium salts. Leaves a fresh and long-lasting fragrance in the environment.</i>	Per tutti i tipi di superfici dure, diluire dall'1 al 3%. In caso di contaminazioni tenaci e cattivi odori aggressivi diluire fino al 6%. <i>On all types of hard surface, dilute from 1 to 3%. In the case of tenacious contaminations and aggressive unpleasant odours, dilute up to 6%.</i>	T1  T2  T3  T5  T7 
LCN-680AL codice/code 3.697.0025  Ph 6,6 - 7,0 1,000 g/ml  5000 ml x 4 pz.	DETERGENTE MANUTENTORE ALCOLICO ALCOHOLIC MAINTENANCE DETERGENT	Detergente neutro universale ad asciugatura rapida. Effetto antipolvere per 4-5 giorni. Profuma gradevolmente l'ambiente e non lascia residui. <i>Quick-drying universal neutral detergent. Anti-dust effect for 4-5 days. Leaves a pleasant fragrance in the environment. Does not leave residues.</i>	Per tutti i tipi di superfici lavabili brillanti e dure quali vetro, pietra, ceramica, diluire in acqua dallo 0.5% all' 1 %. <i>On all types of washable shiny or hard surface such as glass, stone or ceramic, dilute with water from 0.5% to 1 %.</i>	T1  T3  T5  T7 











ARTICOLO MODEL	DESCRIZIONE DESCRIPTION	PROPRIETA' PROPERTIES	ISTRUZIONI PER L'USO: USE:	
LCN-650 codice/code 3.697.0026  Ph 6,3 - 6,7 1,000 g/ml  5000 ml x 4 pz.	DETERGENTE MANUTENTORE NON ALCOLICO NON ALCOHOLIC MAINTENANCE DETERGENT	Detergente neutro universale, non intacca protezioni polimeriche, cere naturali e sintetiche. Profuma gradevolmente l'ambiente, non lascia residui. Universal neutral detergent, does not corrode polymers, natural or synthetic waxes. Leaves a pleasant fragrance in the environment. Does not leave residues.	Per tutti i tipi di superfici lavabili dure, anche se protetti da cere e/o sigillanti, diluire in acqua al 0.5%-1%. On all types of washable hard surfaces, even if protected by wax and/or sealants, dilute in water to 0.5%-1%.	T1  T3  T7 
LCN-640WM codice/code 3.697.0027  Ph 5,9 - 6,9 1,000 g/ml  5000 ml x 4 pz.	DETERGENTE LAVAINCERA NON STRATIFICANTE NON STRATIFYING WAX WASH DETERGENT	Deterge e dona lucentezza alle superfici, rigenera i trattamenti protettivi e le cere. Non è filmogeno e lascia una gradevole profumazione nell'ambiente. Cleans and shines surfaces. Regenerates protective and wax treatments. Non filmogenous and leaves a pleasant fragrance in the environment.	Per tutti i tipi di superfici lavabili dure; anche per pavimenti protetti da cere e/o sigillanti, diluire in acqua al 0.5%-1%. On all types of washable hard surfaces, including floors protected by wax and/or sealants, dilute in water to 0.5%-1%.	T1  T6  T7 
LCB-900WR codice/code 3.697.0030  Ph 8,8 - 9,2 1,000 g/ml  5000 ml x 4 pz.	DETERGENTE DECERANTE NON PROFUMATO FRAGRANCE-FREE WAX REMOVING DETERGENT	Rimuove polimeri e cere di qualsiasi natura, anche se vecchi o stratificati. Removes any type of wax or polymer (even if old or stratified).	A seconda del grado di sporco e dello spessore del film, diluire in acqua dall'1% al 10%. In situazioni estreme, diluire in acqua fino al 20%. According to the degree of dirt and the thickness of the film, dilute in water from 1% to 10%. In extreme situations, dilute in water up to 20%.	T1  T6  T7 

ARTICOLO MODEL	DESCRIZIONE DESCRIPTION	PROPRIETA' PROPERTIES	ISTRUZIONI PER L'USO: USE:	
LCB-740F codice/code 3.697.0031  Ph (sol. 1%) 6.9 - 7.9 1,000 g/ml  5000 ml x 4 pz.	DETERGENTE ALCALINO MULTIUSO ALKALINE MULTIPURPOSE DETERGENT	Scioglie e distacca sporco di natura organica ed inorga- nica. <i>Dissolves and detaches organic and inorganic dirt.</i>	Per tutti i tipi di superfici lavabili dure, rivestimenti in ceramica o smaltati, infissi at- trezzature e macchine utensili, diluire in acqua dall'1% al 2%. <i>On all types of hard washable surfaces, ceramic or enamelled surfaces, windows and doors, equipment and industrial machine tools. Dilute in water from 1% to 2%.</i>	T1  T2  T4  T7 
LCN-600SVF codice/code 3.697.0033  Ph 5,8 - 6,2 0,950 g/ml  5000 ml x 4 pz.	DETERGENTE-SOLVENTE DI ORIGINE VEGETALE SOLVENT DETERGENT OF VEGETABLE ORIGIN	Elimina residui di catrame, gomma, vernice e colla. Asporta film cerosi (acrilici o polimerici) anche stratificati. Disgrega sporchi persistenti di natura animale o minerale. <i>Eliminates tar, rubber, glue and adhesive residues. Removes even stratified (acrylic or polymer) wax films. Disintegra- tes persistent dirt of animal or mineral origin.</i>	A seconda del grado di sporco e dello spessore del film, dilui- re in acqua dall'0.5% al 2% <i>According to the degree of dirt and thickness of the film, dilute in water from 0.5% to 2%.</i>	T1  T2  T5  T6  T7 
LCN-700 codice/code 3.697.0035  Ph 6.8 - 7.2 1,010 g/ml  5000 ml x 4 pz.	DETERGENTE PER LAVAGGIO MOQUETTE E TESSUTI CARPET AND TEXTILE WASH DETERGENT	Rimuove lo sporco, rigenera e protegge i tessuti. Non lascia residui ed emana una grade- vole profumazione. <i>Removes dirt, regenerates and protects fibres. Does not leave residues and releases a pleasant fragrance.</i>	Diluire in acqua dal 2% al 5%. <i>Dilute in water from 2% to 5%.</i>	T3  T5 

ARTICOLO MODEL	DESCRIZIONE DESCRIPTION	PROPRIETA' PROPERTIES	ISTRUZIONI PER L'USO: USE:	
SPRAYER codice/code 0.010.0029  Ph (sol. 2%) 10,3 1,000 g/ml  2000 ml x 12 pz.	DETERGENTE ALCALINO MULTIUSO ALKALINE MULTIPURPOSE DETERGENT	Detergente schiumogeno concentrato ad elevata resa. Rimuove efficacemente olio, grasso, smog, residui petroliferi e sporchi tenaci in genere, da carrozzerie, motori parte esterna, superfici metalliche e alluminio. <i>High efficiency concentrated detergent. Effectively removes oil, grease, pollution, waste oil and heavy soil generally from car bodies, engines outside, and aluminum metal surfaces.</i>	Diluire con acqua nella misura di 1 a 10-50 parti, spruzzare sulla superficie da pulire in modo uniforme dal basso verso l'alto, lasciare agire pochi istanti quindi risciacquare abbondantemente con idropulitrice. <i>Dilute with water at the rate of 1 to 10-50 parts, spray on the surface to be cleaned in a uniform manner from bottom to top, leave a few minutes then rinse thoroughly with high pressure washer.</i>	T2  T4 
CAR codice/code 0.010.0030  Ph 7,5 1,000 g/ml  2000 ml x 12 pz.	DETERGENTE NEUTRO PER LAVAGGIO AUTO NEUTRAL DETERGENT FOR CAR WASH	Detergente neutro a base di speciali tensioattivi ad elevato potere emolliente nei confronti dello sporco. Efficace su sporco inorganico di oli, grassi, smog e terriccio. Indicato per la pulizia di autovetture, roulettes, carrelli tenda, motociclette, biciclette. <i>Neutral detergent with high emollient power against the dirt. Effective on inorganic dirt, oil, grease, dirt and smog. Suitable for cleaning cars, caravans, trailer tents, motorbikes and bicycles.</i>	Applicare direttamente il flacone alla lancia dell'idropulitrice, nebulizzare sulla superficie da pulire, lasciare agire alcuni istanti quindi risciacquare abbondantemente. <i>Apply directly with the foam injector lance of the high pressure cleaner, spray on surface to be cleaned, leave in a few seconds then rinse thoroughly.</i>	T2  T4 
TEXIL codice/code 0.010.0031  Ph 8 1,040 g/ml  2000 ml x 12 pz.	DETERGENTE PER LAVAGGIO MOQUETTE E TESSUTI CARPET AND TEXTILE WASH DETERGENT	Speciale detergente indicato per la pulizia delle moquette e degli interni in stoffa delle automobili. Utilizzabile sia manualmente che con macchine lavamoquette ad estrazione. <i>Special detergent suitable for cleaning carpets and interior fabric of cars. Can be used manually or with injection-extraction machines.</i>	Diluire con acqua nella misura di una parte con 10 di acqua, spruzzare sulla superficie da pulire, lasciare agire per 1-3 minuti quindi aspirare o spazzolare ed infine asciugare con spugna. <i>Dilute with water at the rate of 1 to 10 parts, spray on the surface to be cleaned, leave for 1-3 minutes then vacuum or brush and then dry with a sponge.</i>	T1  T3 

ARTICOLO MODEL	DESCRIZIONE DESCRIPTION	PROPRIETA' PROPERTIES	ISTRUZIONI PER L'USO: USE:	
LC-PREFOAM codice/code 3.697.0036  Ph 6.0 - 8.0 1,000 g/ml  1000 ml x 6 pz.	ABBATTITORE DI SCHIUMA FOAM SUPPRESSOR	Prodotto a base silconica per l'abbattimento della schiuma. <i>Silicone based product to suppress foam.</i>	Versare il prodotto in piccole dosi leggermente diluito o concentrato all'interno del serbatoio o fusto di recupero sporco. <i>Pour the product in small slightly diluted or concentrated doses inside the dirt collection tank or container.</i>	T3  T7 
LC-PRECAL codice/code 3.697.0037  pH (sol. 1%) 1 - 1.8 1,000 g/ml  1000 ml x 6 pz.	ANTICALCARE ANTI-SCALE	Impedisce depositi calcarei in componenti e condotti a contatto con acqua calda o vapore. <i>Prevents scale from depositing in components and ducts in contact with hot water or steam.</i>	Generatori di vapore: versare nel serbatoio di alimentazione diluito in acqua dall' 1% al 3%. Idropulitrici: versare concentrato nell'apposita vaschetta dosatore automatico. <i>Steam generators: pour into the supply tank diluted in water from 1% to 3%. High pressure cleaners: pour concentrate into the appropriate automatic dispenser.</i>	T4  T5 
DESCALER codice/code 0.010.0032  Ph 3 1,310 g/ml  2000 ml x 12 pz.	ACIDO DISINCROSTANTE DESCALING ACID	Prodotto acido indicato per eliminare le incrostazioni di calcare da caldaie e serpentine di idropulitrici. <i>Acid detergent suitable for removing scale deposits from boilers and high pressure washers coils.</i>	Usare una parte di Descaler ogni tre parti di acqua; fare riciclare la soluzione a circuito chiuso per circa 15-20 minuti, quindi scaricare il circuito e risciacquare abbondantemente con acqua. <i>Dilute with water at the rate of 1 to 3 parts; circulate the solution in closed loop for about 15-20 minutes and then empty the circuit and rinse thoroughly with water.</i>	T4  T5 

ARTICOLO MODEL	DESCRIZIONE DESCRIPTION	PROPRIETA' PROPERTIES	ISTRUZIONI PER L'USO: USE:	
MUSCAL codice/code 0.010.0033  Ph 9,5 1,010 g/ml 2000 ml x 12 pz.	ANTIMUSCHIO ANTI-MOSS	Speciale formulato indicato per eliminare muschio, muffe e alghe da pareti, pavimentazioni esterne e superfici piastrelate. Indicato inoltre come trattamento anti-alga per acque ad uso industriale. <i>Special formula to remove moss, mildew and algae from walls, external floors and tiled surfaces. Also indicated as a treatment for algae water for industrial use.</i>	Spruzzare il prodotto tal quale direttamente sulle parti da trattare, lasciare agire alcuni minuti quindi asportare il tutto con spazzola o getto d'acqua. Per il trattamento di acque industriali aggiungere 1 litro di prodotto ogni 150/200 litri. <i>Spray the product as it is directly on the areas to be treated, leave a few minutes and then remove with brush or water spray. For the treatment of industrial water, add 1 liter of product each 150/200 liter.</i>	T2  T4 
STEAM PRECAL codice/code 0.010.0028  Ph 1 - 1,8 50 gr x 25 pz.	ANTICALCARE IN POLVERE ANTI-SCALE POWDER	Impedisce depositi calcarei in componenti e condotti a contatto con acqua calda o vapore. <i>Prevents scale from depositing in components and ducts in contact with hot water or steam.</i>	Versare mezza bustina ad ogni riempimento della caldaia. Aumentare o diminuire la dose a seconda del grado di durezza dell'acqua. <i>Pour half a bag at every filling of the boiler. Increase or decrease the dose depending on the hardness of the water.</i>	T5 
STEAM LIQUID PRECAL codice/code 0.010.0036  Ph 7,2 1,012 g/ml 100 ml x 4 pz.	ANTICALCARE LIQUIDO LIQUID ANTI-SCALE	Impedisce depositi calcarei in componenti e condotti a contatto con vapore. <i>Preventes scale deposits in components and pipes which come into contact with steam.</i>	Versare il contenuto di un tappo ad ogni riempimento della caldaia; due o più tappi in caso di acqua particolarmente dura. Dopo l'utilizzo di un flacone si consiglia il lavaggio della caldaia. <i>Pour the contents of a capful at each filling of the boiler, two or more caps in the case of particularly hard water. After using the entire bottle, it is advisable to wash out the boiler.</i>	T5 

ARTICOLO MODEL	DESCRIZIONE DESCRIPTION	PROPRIETA' PROPERTIES	ISTRUZIONI PER L'USO: USE:	
HYGIENIC PARFUM codice/code 0.010.0035  Ph (sol. 2%) 10,3 1,000 g/ml  100 ml x 4 pz.	IGIENIZZANTE PROFUMATO PER ASPIRAPOLVERI/LIQUI- DI CON FILTRAGGIO AD ACQUA SANITIZER FOR DUST/LIQUID VACUUM CLEANERS WITH WATER FILTERING	Igienizzante profumato particolarmente indicato per profumare l'ambiente mentre si lavora con l'aspiratore. Ottimo anche per l'igienizzazio- ne dell'acqua di filtraggio. previene la formazione di cattivi odori. <i>Sanitizer particularly suitable for perfuming the environment while working with a vacuum cleaner. Also great for sani- zing the filtering water. Prevents the formation of bad smells.</i>	Versare una dose (un tappo) nel serbatoio insieme all'ac- qua. <i>Pour one dose (one cap) in the tank together with the water.</i>	T3 
SCRUBBER HYGIENIC PARFUM codice/code 0.010.0037  Ph 10,3 1,000 g/ml  100 ml x 4 pz.	DETERGENTE PER LAVAPAVI- MENTI DETERGENT FOR FLOOR SCRUBBERS	Detergente profumato ad elevato potere emolliente nei confronti dello sporco. Indicato per la pulizia di tutti i tipi di pavimento, interni ed esterni. <i>Perfumed detergent, highly emollient against the dirt. Suitable for cleaning all types of floors, interior and exterior.</i>	Versare una dose (metà flacone) nel serbatoio pieno d'acqua. <i>Pour a dose (half bottle) in the tank full of water.</i>	T3  T7 
SCRUBBER HYGIENIC PARFUM codice/code 0.010.0014  16 confezioni del codice 0.010.0034 16 packages of code 0.010.0034	DETERGENTE PER LAVAPAVI- MENTI DETERGENT FOR FLOOR SCRUBBERS	Detergente profumato ad elevato potere emolliente nei confronti dello sporco. Indicato per la pulizia di tutti i tipi di pavimento, interni ed esterni. <i>Perfumed detergent, highly emollient against the dirt. Suitable for cleaning all types of floors, interior and exterior.</i>	Versare una dose (metà flacone) nel serbatoio pieno d'acqua. <i>Pour a dose (half bottle) in the tank full of water.</i>	T3  T7 

Note/Notes:

Lined area for notes, featuring horizontal ruling lines across the page.

LAVORWASH
SERVICE



LAVORWASH S.p.A. J.F.Kennedy, 12 - 46020 Pegognaga (MN) Italy - Tel. +39 0376 55431 - Fax +39 0376 558927
E-mail: info@lavorservice.it - WebSite: www.lavorservice.com